



Cerema ITM
110 rue de Paris
77171 Sourdun
FRANCE

E-mail: clients-ete@cerema.fr
web: www.cerema.fr

European Technical Assessment

ETA 06/0006
of 12/05/2026

General part

Technical Assessment Body issuing the ETA	Cerema Direction technique infrastructures de transport et matériaux
Trade name of the construction product	VSL Post-Tensioning System
Product family to which the construction product belongs	16. Reinforcing and prestressing steel for concrete (and ancillaries). Post tensioning kits.
Manufacturer	VSL INTERNATIONAL Ltd. Wankdorfallée, 5 CH-3014 Bern SWITZERLAND http://www.vsl.com/
Manufacturing plants	VSL Systems Manufacturer S.L. Ribera del Congost, s/n - P. I. El Congost 08520 Les Franqueses del Vallès Barcelona SPAIN VSL Engineering Corp. Ltd. 2429 Zishi Rd., Economic and Technological Development Area Hefei City, Anhui Province– P. R. CHINA
This European Technical Assessment contains	142 pages including 4 Annexes (130 pages) which form an integral part of this assessment.
This European Technical Assessment is issued in accordance with Article 95(4) of Regulation (EU) 2024/3110, on the basis of	EAD 160004-00-0301 “Post-tensioning kits for prestressing of structures”
This ETA replaces	ETA 06/0006 version 4 issued on 20/06/2019

Translations of this European Technical Assessment in other languages shall fully correspond to the original issued document and should be identified as such. Communication of this European Technical Assessment, including transmission by electronic means, shall be in full (excepted the confidential Annex(es) referred to above). However, partial reproduction may be made, with the written consent of the issuing Technical Assessment Body. Any partial reproduction has to be identified as such.

VSL Post-Tensioning System

Content

GENERAL PART	1
SPECIFIC PARTS	3
1 TECHNICAL DESCRIPTION OF THE PRODUCTS	3
1.1 VSL Multistrand System	3
1.2 VSL Slab System	4
2 SPECIFICATIONS OF THE INTENDED USE IN ACCORDANCE WITH THE APPLICABLE EUROPEAN ASSESSMENT DOCUMENT	4
3 PERFORMANCE OF THE PRODUCTS AND METHODS USED FOR ITS ASSESSMENT	6
4 ASSESSMENT AND VERIFICATION OF CONSTANCY OF PERFORMANCE, WITH REFERENCE TO ITS LEGAL BASE ..	8
5 TECHNICAL DETAILS NECESSARY FOR THE IMPLEMENTATION OF THE AVCP SYSTEM, AS PROVIDED FOR IN THE APPLICABLE EAD	9
5.1 Tasks for the Manufacturer	9
5.2 Tasks of the Notified Body	11
ANNEXES	13
ANNEX A TECHNICAL DATA OF THE VSL MULTISTRAND SYSTEM	13
A.1 Definition of the system	14
A.2 Strands and ducts	20
A.3 Anchorages	28
A.4 Stressing	37
A.5 Injection and sealing	38
A.6 Schematic drawings	41
ANNEX B TECHNICAL DATA OF THE VSL SLAB SYSTEM	95
B.1 Definition of the system	96
B.2 Strands and ducts	100
B.3 Anchorages	106
B.4 Stressing	112
B.5 Injection and sealing	115
B.6 Schematic drawing	117
ANNEX C PRESCRIBED TEST PLAN AND AUDIT TESTING	138
C.1 Prescribed test plan	138
C.2 Audit testing	140
ANNEX D REFERENCE STANDARDS AND GUIDELINES	141
D.1 Material and reference standards	141
D.2 EADs and recommendations	141
D.3 Standards and norms	142

Specific parts

1 Technical description of the products

The VSL Post-Tensioning Systems covered by this ETA are the VSL Multistrand System and the VSL Slab System. They are used for the prestressing of structural elements of civil works and buildings.

The tendons of these systems use strand complying with *prEN 10138-3: Prestressing steels - Part 3: Strand*. As long as EN 10138 remains a prestandard, 7-wire strands in accordance with national provisions shall be used. Steel strands may be bare strands, individually greased and sheathed monostrands complying with EAD 160004-00-0301 or individually greased strands protected by tightly extruded PE coating (adherent protected and sheathed strand).

Other components, such as anchorages and/or couplers and protective products are described below.

1.1 VSL Multistrand System

The VSL Multistrand System (from 1 to 55 strand cables), defined in [Annex A](#) is mainly used for civil engineering structures. It is formed by the strands specified above and the following components:

1.1.1 Ducts

- Metallic: corrugated steel strip sheaths, steel tubes
- Polymeric: the VSL PT-PLUS® ducting, polyethylene or polypropylene sheaths or tubes

1.1.2 Anchorages

- Active or passive anchorages type E (1 to 55 strands), type CS (7 to 37 strands), type GC (3 to 55 strands), type NC (55 strands) and type NC-U (55 strands)
- Passive anchorages type EP (3 to 55 strands)
- Passive bonded anchorages type H (1 to 37 strands)
- Fixed couplers type K (3 to 37 strands) and movable couplers type V (3 to 37 strands)

1.1.3 Injection products

- For rigid injection: with a cement base, in accordance with EN 447
- For flexible injection: with a grease, wax, or polymer base

Filling materials covered by an ETA may also be employed. Grease, wax and cementitious grouts have to comply with EAD 160027-00-0301.

1.2 VSL Slab System

The VSL Slab System (1 to 4 strands) defined in [Annex B](#) is mainly used for floors in buildings, slab on grade and bridge decks. It is used with the strands specified above that may be bare strands for the system with injection (bonded tendons) or individually greased and sheathed strands for the system without injection (unbonded tendons):

1.2.1 Ducts

For the system with injection ducts may be circular or flat corrugated steel strip sheaths or VSL PT-PLUS® ducts.

1.2.2 Anchorages

- Active or passive type S 6-1 (1 strand), S 6-1 PLUS (1 strand), S6-1 Standard (1 strand) and type S 6-4 (4 strands),
- Spring-loaded coupler SLC 6-1 (1 strand)
- Bonded passive type H (1 to 4 strands) for internal bonded tendons only.

The units of the VSL Slab system included in this ETA have 1 or 4 strands. Slab units type VSLab® with 2, 3, 4 and 5 strands are covered by ETA 13/0978.

1.2.3 Injection products

Injection products used for bonded tendons have a cement base, in accordance with EN 447. Wax, grease or polymers may be used for unbonded tendons. Filling materials covered by an ETA may also be employed. Grouts, wax and grease have to comply with EAD 160027-00-0301.

2 Specifications of the intended use in accordance with the applicable European Assessment Document

The VSL Post-Tensioning System has been designed to be used for:

- New structural works
- Repair and strengthening of existing structures

The VSL Post-Tensioning System is mainly used in concrete structures, but may also be employed in structures made of other materials (such as masonry, steel, cast iron, wood) or of a combination of several materials (such as steel and concrete).

The tendons of the VSL Post-Tensioning System may have the following basic use categories:

- Internal bonded tendon for concrete and composite structures
- Internal unbonded tendon for concrete and composite structures
- External tendon for concrete and composite structures with a tendon path situated outside the cross section of the structure or member but inside its envelope

Cables for ground and rock anchors, external cables with a layout positioned beyond the structural envelope or the structural component and stay cables are not covered by the present ETA.

VSL Post-Tensioning System

The following optional use categories are possible:

- Restressable tendon (internal or external)
- Exchangeable tendon (internal or external)
- Internal tendon for cryogenic applications with anchorage inside and outside the possible cryogenic zone
- Internal bonded tendon with corrugated plastic duct
- Encapsulated tendon
- Electrically isolated tendon
- Tendon for use in structural steel or composite construction as external tendon
- Tendon for use in structural masonry construction as internal and/or external tendon
- Tendon for use in structural timber as internal and/or external tendon

The use categories above can be combined for particular applications, for instance as follows:

- External tendon with grouted duct
- External tendon with soft filler and duct
- External tendon using adherent protected and sheathed strands

The tables presented in [Clause A.1.4.1 - Uses and options of the VSL multistrand system](#) and [Clause B.1.4.1 - Uses and options of the VSL Slab system units](#) present the possible categories of use for each of the approved anchorages.

The assessment methods included or referred to in the EAD 160004-00-0301 have been written based on the manufacturer's request to take into account a working life of the PT kit for the intended use of 100 years when installed in the works provided that the PT kit is subject to appropriate installation (see Chapter 1 of EAD 160004-00-0301). These provisions are based upon the current state of the art and the available knowledge and experience.

The real working life may, under normal use conditions, be considerably longer provided that there is no major degradation affecting the work itself. The real working life of a product incorporated in a specific work depends on the environmental conditions to which that work is subjected, as well as on the particular conditions of the design, execution, use and maintenance of that work. Therefore, it cannot be excluded that in certain cases the real working life of the product may also be shorter than the working life referred to above.

The indications given on the design working life of a product cannot be interpreted as a guarantee given by the producer (or the Technical Assessment Body) but are regarded only as a means for expressing the expected economically reasonable working life of the product.

3 Performance of the products and methods used for its assessment

This European Technical Assessment for the post-tensioning system is issued on the basis of the relevant data that have been deposited at Cerema ITM and identify the post-tensioning system that has been assessed.

Assessment of the performance of the post-tensioning system described in this document has been made in accordance with the European Assessment Document EAD 160004-00-0301 for Post – Tensioning Kits for Prestressing of Structures, in the sense of Basic Works Requirement 1 (Mechanical resistance and stability), based on the provisions for all systems.

Table 3.1 – Performances

Product type: Post–Tensioning Kit		Intended use: Prestressing of structures (all basic use categories)
Basic Works Requirement 1: Mechanical resistance and stability		
No	Essential characteristic	Type of expression of product performance
1	Resistance to static load	≥ 95 % of Actual Ultimate Tensile Strength –AUTS (acceptance criteria given in clause 2.2.1 of EAD 160004-00-0301)
2	Resistance to fatigue	No fatigue failure in anchorage and not more than 5 % loss on cross section after 2 million cycles (acceptance criteria given in clause 2.2.2 of EAD 160004-00-0301)
3	Load transfer to the structure	Stabilization of crack width under cyclic load and ultimate resistance ≥ 110 % characteristic load (acceptance criteria given in clause 2.2.3 of EAD 160004-00-0301)
4	Friction coefficient	See clauses A.2.6.1 and B.2.7.1 (acceptance criteria given in clause 2.2.4 of EAD 160004-00-0301)
5	Deviation/deflection (limits) for internal bonded and internal unbonded tendon	See clauses A.2.3.2 and B.2.4.2 (acceptance criteria given in clause 2.2.5 of EAD 160004-00-0301)
6	Deviation/deflection (limits) for external tendon	See clauses A.2.3.2 and B.2.4.2 (acceptance criteria given in clause 2.2.6 of EAD 160004-00-0301)
7	Assessment of assembly	Installation of strands, duct filling (acceptance criteria given in clause 2.2.7 of EAD 160004-00-0301)
8	Resistance to static load under cryogenic conditions for applications with anchorage/coupling outside the possible cryogenic zone	≥ 95 % of Actual Ultimate Tensile Strength –AUTS (acceptance criteria given in clause 2.2.8 of EAD 160004-00-0301)
9	Resistance to static load under cryogenic conditions for applications with anchorage/coupling inside the possible cryogenic zone	≥ 95 % of Actual Ultimate Tensile Strength –AUTS (acceptance criteria given in clause 2.2.9 of EAD 160004-00-0301)
10 to 34	See EAD 160004-00-0301, Clause 2.1, Table 1	No performances assessed.
Basic Works Requirement 2: Safety in case of fire		
35	Reaction to fire	No performance assessed.
Basic Works Requirement 3: Hygiene, health and the environment		
36	Content, emission and/or release of dangerous substances	No performance assessed.

VSL Post-Tensioning System

For the particular application 'External tendon with adherent and protected sheathed strand' the following additional basic requirement has been assessed:

Basic requirement for construction work	Essential characteristic	Performance
1 Mechanical resistance and stability	Deviation/Deflection (limits)	<p>Acceptable wear of tensile element sheathing for tendons up to 31 strands in case of unintentional deviation or small intentional deviation of not more than 2+2° degrees with specific flat saddle detail or 5+5° with a specific curved saddle (acceptance criteria given in clause 2.2.6 of EAD 160004-00-0301)</p> <p>Acceptable wear of tensile element sheathing for tendons up to 31 strands with the following deviations and details:</p> <ul style="list-style-type: none"> • Intentional deviation up to 2° per unit of XT super compact pad (or a multiple of this deviation with a succession of XT super compact pads taking up to 2° each) and additional unintentional deviation of 0.5° • Intentional deviation up to 3° per unit of XT compact or XT parallel pad (or a multiple of this deviation with a succession of XT compact or XT parallel pads taking up to 3° each) and additional unintentional deviation of 0.5° <p>(acceptance criteria given in clause 2.2.6 of EAD 160004-00-0301)</p>

4 Assessment and verification of constancy of performance, with reference to its legal base

The components of the VSL Post-Tensioning System comply with the drawings and conditions described in [Annex A - Technical data of the VSL Multistrand system](#) and [Annex B - Technical data of the VSL Slab system](#).

More detailed information related to confidential specifications (including materials, processing, surface, dimensions, tolerances, manufacturing methods and control procedures) are included in the Technical Assessment file concerning this European Technical Assessment, which has been deposited at the Technical Assessment Body. This set of information is also to be sent, whenever necessary, to the Notified Body responsible for AVCP.

In accordance with the decision 98/456/EC1 of the European Commission, the system 1+ of assessment and verification of constancy of performances (see Annex V to Regulation (EU) No 305/2011), given in the following table applies:

Table 4.1 – AVCP System

Product(s)	Intended use(s)	Level(s) or class(es)	System(s)
Post-tensioning Kits	For the prestressing of structures	-	1+

The AVCP system 1+ includes the following:

(a) Tasks of the manufacturer

- (1) Factory production control
- (2) Further testing of samples taken at the factory by the manufacturer in accordance with a prescribed test plan
- (3) Declaration of the performance of the essential characteristics of the construction product

(b) Tasks for the Notified Body

- (4) Initial type testing
- (5) Initial inspection of factory and of factory production control
- (6) Continuous surveillance, assessment and approval of factory production control
- (7) Audit testing of samples taken at the factory, including Single Tensile Element tests on samples supplied by the manufacturer

A set of specific tests were carried out as stated in EAD 160004-00-0301 for the following optional use categories: electrical insulation and cryogenic applications.

The methods for verifying, evaluating and assessing suitability and test procedures comply with those detailed in EAD 160004-00-0301.

1 Official Journal of the European communities L201/112 of 3 July 1998

5 Technical details necessary for the implementation of the AVCP system, as provided for in the applicable EAD

5.1 Tasks for the Manufacturer

5.1.1 General responsibilities of the Manufacturer

The Manufacturer is responsible for the production and quality of components manufactured or ordered.

The Manufacturer shall keep available an updated list of all Component Manufacturers. This list shall be submitted to the Notified Body and the Technical Assessment Body.

Each Component Manufacturer shall be audited by the manufacturer at least once per year. Each audit report shall be made available to the Notified Body.

These audit reports include:

- Identification of the Component Manufacturer
- Date of audit of the Component Manufacturer
- Summary of the results and records of the FPC since last audit
- Summary of the complaint records
- Evaluation of the components manufacturer concerning FPC
- Specific remarks as relevant
- Clear and unique statement whether the requirement of the ETA are met
- Name and position of signatory
- Date of signature
- Signature.

The Manufacturer makes available for at least 10 years all records of relevant results concerning the ETA and the audit reports concerning the Component Manufacturers.

5.1.2 Factory Production Control (FPC)

The Manufacturing Plant or the designated factory (formerly designated as Kit Manufacturer) exercises permanent internal control of the production. All the elements, requirements and provisions adopted by the Manufacturer are documented in a systematic manner in the form of written policies and procedures. This control system ensures that the PT System is in conformity with the European Technical Assessment.

The FPC is in accordance with the Quality Manual of the Manufacturer that has been submitted to the Technical Assessment Body and the Notified Body.

The FPC complies with the Table 3 of EAD 160004-00-0301 (Control plan for the Manufacturer; cornerstones). The results of the FPC are recorded and evaluated in accordance with the provisions of the Prescribed Test Plan presented in [Annex C - Prescribed test plan and audit testing](#).

Parts of the FPC may be transferred to an independent test laboratory. Nevertheless, the Manufacturer has the full responsibility for all results of the FPC.

5.1.3 Other tasks

5.1.3.1 Control of the PT System components and materials

The characteristics of incoming materials which comply with a harmonized European technical specification are considered satisfactory and need, except in case of justified doubt, no further checking. All materials are to be in accordance with the requirements of the ETA and the corresponding specifications of the Manufacturer.

Where harmonized technical specifications are not available, materials according to specifications valid in the place of use may be used provided that their use is compatible with the results of the approval tests. Otherwise, the specifications are given in the ETA.

5.1.3.2 Inspection and testing

The type and frequency of checks / testing conducted during production and on the final product is defined in the prescribed test plan. This plan indicates the checks conducted during production on properties that cannot be inspected at a later stage and inspection of the final product, including:

- Definition of frequency and number of samples taken by the Manufacturing Plant
- Material properties to be checked (such as tensile strength, hardness, surface finish, chemical composition, etc.)
- Determination of the dimensions of components
- Trial assemblies (when they are required)
- Documentation of checks and test results.

All tests are performed according to written procedures with suitable calibrated measuring devices. All test results are recorded in a consequent and systematic way.

The prescribed test plan relative to the PT System (see [Annex C - Prescribed test plan and audit testing](#)) complies with the requirements of table 3 of EAD 160004-00-0301, including the minimum test frequencies to perform.

5.1.3.3 Control of non-conforming products

Products which are considered as not conforming to the ETA are immediately marked and separated from the complying products. The prescribed test plan addresses control of non-conforming products.

5.1.3.4 Complaints

The quality management system of the Manufacturer includes provisions to keep records of all complaints about the PT System.

5.2 Tasks of the Notified Body

5.2.1 General responsibilities of the Notified Body

The Notified Body shall perform the following tasks in accordance with the Table 4 of EAD 160004-00-0301 (Control plan for the notified body; cornerstones):

- Initial type testing
- Initial inspection of factory and of factory production control
- Continuous surveillance, assessment and approval of factory production control
- Audit testing of samples taken at the factory, including Single Tensile Element tests on samples supplied by the Manufacturer

The Notified Body is responsible for the Assessment and Verification of the Constancy of Performances (AVCP) of the Manufacturer. The Notified Body shall issue an AVCP certificate of the product stating the conformity with the provisions of this European Technical Assessment.

In case the provisions of the European Technical Assessment and its prescribed test plan are no longer fulfilled, the Notified Body shall withdraw the AVCP certificate and inform Cerema without delay.

The Notified Body may act with its own resources or subcontract inspection tasks and testing tasks to inspection bodies and testing laboratories.

5.2.1.1 Initial type testing

The results of the tests performed during the assessment procedure and then assessed by the Technical Assessment Body may be used by the Notified Body as Initial type testing.

5.2.1.2 Initial assessment of factory and of factory production control

The Notified Body assesses both the factory capacities and the factory production control performed by the Manufacturing Plant in order to ensure that, in compliance with the prescribed test plan, the manufacturing resources and FPC are able to guarantee continuous and consistent manufacturing of PT System components in accordance with the ETA specifications. These tasks shall comply with the prescribed test plan and with the conditions described under the heading *Initial inspection of the manufacturing plant and of the factory production control* of Table 4 of EAD 160004-00-0301.

5.2.1.3 Continuous surveillance, assessment and approval of factory production control

The Notified Body shall perform surveillance inspections, Component Manufacturers inspections and sample extractions either in the factories or on the job sites for the purpose of conducting independent tests under its responsibility. These tasks shall comply with the prescribed test plan and with the conditions described under the heading *Continuous surveillance, assessment and evaluation of factory production control* of Table 4 of EAD 160004-00-0301.

The Manufacturing Plant shall be inspected at least once a year by the Notified Body. Each Component Manufacturer shall be checked at least once every five years by the notified body. At the issue of these audits, the Notified Body shall make available a written report.

The Notified Body shall provide to Cerema, upon request, the results of certification and continuous surveillance. In cases of serious non conformities, related to important aspects of the performances of the post-tensioning system, which cannot be corrected within the deadlines, the Notified Body shall withdraw the certification of AVCP and inform the Cerema without delay.

5.2.1.4 Audit testing of samples taken at the factory

During surveillance inspection, the Notified Body shall take samples at the factory for independent testing of components of the PT system included in this European technical assessment. For the most important components, the [Annex C](#) summarises the minimum procedures. These tasks shall comply with the prescriptions of the section *Audit-testing of samples taken by the notified product*

VSL Post-Tensioning System

certification body at the manufacturing plant or at the manufacturer's storage facilities of Table 4 of EAD 160004-00-0301.

At least once a year specimens are taken by the Manufacturer from the Manufacturing Plant. One series of single tensile element tests shall be performed with these specimens by the Notified Body according to [Annex C - Prescribed test plan and audit testing](#) (following Annex C.7 of EAD 160004-00-0301). The relevant reports include:

- Identification of the plant where the components have been taken
- Date of sampling
- Identification of the components (i. e. anchorage, strand, etc.)
- Place and date of testing
- Summary of the results including a test report
- Specific remarks as relevant
- Name and position of signatory
- Date of signature
- Signature

Issued in Sourdun on 12 May 2026

By

Centre d'étude et d'expertise sur les risques, l'environnement, la mobilité et l'aménagement
Direction technique Infrastructures de transport et matériaux

Sophie CARIOU (Deputy director of Cerema ITM), ETA manager

Annexes

Annex A TECHNICAL DATA OF THE VSL MULTISTRAND SYSTEM

A.1	DEFINITION OF THE SYSTEM	14
A.1.1	PRINCIPLE OF THE VSL MULTISTRAND SYSTEM	14
A.1.2	CHARACTERISTICS OF SYSTEM UNITS	15
A.1.3	ANCHORAGES	17
A.1.4	CATEGORIES OF USE, POSSIBILITIES AND OPTIONS	18
A.2	STRANDS AND DUCTS	20
A.2.1	STRANDS USED	20
A.2.2	DUCTING	20
A.2.3	CABLE LAYOUT	23
A.2.4	INSTALLATION OF DUCTS AND STRANDS	26
A.2.5	PROVISIONAL PROTECTION AND LUBRICATION	26
A.2.6	CALCULATION ELEMENTS	26
A.3	ANCHORAGES	28
A.3.1	DESCRIPTION OF ANCHORAGE COMPONENTS	28
A.3.2	QUALITY ORGANIZATION	30
A.3.3	INSTALLATION OF VSL ANCHORAGES	30
A.3.4	ANCHORAGE ARRANGEMENTS	33
A.3.5	GEOMETRICAL AND MECHANICAL USE CONDITIONS	34
A.3.6	LOCAL ANCHORAGE ZONE REINFORCEMENT	36
A.4	STRESSING	37
A.4.1	STRESSING EQUIPMENT	37
A.4.2	STRESSING PROCEDURE	37
A.5	INJECTION AND SEALING	38
A.5.1	GENERAL INFORMATION	38
A.5.2	INJECTION PRODUCTS (FILLERS)	38
A.5.3	INJECTION EQUIPMENT	39
A.5.4	INJECTION AND CONTROL PROCEDURE	39
A.5.5	SEALING	40
A.6	SCHEMATIC DRAWINGS	41
A.6.1	STANDARD ANCHORAGE PARTS	42
A.6.2	ANCHORAGES TYPE E	47
A.6.3	ANCHORAGES TYPE CS	66
A.6.4	ANCHORAGES TYPE GC	70
A.6.5	ANCHORAGES TYPE NC AND NC-U	81
A.6.6	ANCHORAGES TYPE H @ 28/35 MPA	85
A.6.7	COUPLERS TYPE K	87
A.6.8	COUPLERS TYPE V	89
A.6.9	BLOCK-OUT DIMENSIONS – CLEARANCE REQUIREMENTS	90
A.6.10	XT-DEVIATORS – DIMENSIONS AND CONDITIONS OF USE	91
A.6.11	DUCTING	93

A.1 Definition of the system

A.1.1 Principle of the VSL multistrand system

The cables of the VSL Multistrand System are composed by individual or bundles of strands of high-strength steel and by anchorages placed at its extremities.

The strands are usually encased by a duct, sheath or tube. The void between the strands and the encasement may be filled by a material in order to inhibit corrosion and (in the case of bonded cables) to bond the strands to the structure.

The individual strands comply with *prEN 10138-3: Prestressing steels - Part 3: Strand*. They are 7-wire strands with nominal diameters of \varnothing 15.2 and 15.7 mm ($f_{pk} = 1\,860$ N/mm² or $f_{pk} = 1\,770$ N/mm²). As long as EN 10138 remains a prestandard, 7-wire strands in accordance with national provisions shall be used.

The VSL Multistrand system is compatible with bare strands and also with individually sheathed and protected strands.

By changing the type and number of strands, it is possible to obtain tendons with a characteristic breaking load from 260 to 15 345 kN.

Usually all strands of a cable are simultaneously stressed, with each strand individually locked by a wedge inside a conical anchoring hole. The wedges clamp the strand and allow to transfer the stressing force from the jack to the anchorage.

The design force defines the type and number of strands. The type of anchorage is defined by the project requirements and the category of use.

The post-tensioning cables are usually defined by the anchorages (see [Clause A.3](#)), the type of strand and the length.

As an example, a “*cable VSL E 6-12 Y1860 S7-15.7 L= 50.0 m*” is a cable 50 m long, formed by 12 strands with nominal diameter 15.7 mm, $f_{pk} = 1860$ MPa, and with two VSL E anchorages at its extremities.

The VSL system includes anchorages with 1 - 2 - 3 - 4 - 7 - 12 - 15 - 19 - 22 - 27 - 31 - 37 - 43 and 55 strands. The intermediate units can be created leaving free some conical holes of the anchorage. In this case, the strands have to be arranged to centre the applied load to the anchor head.

A.1.2 Characteristics of system units

The system can be used with strands with lower characteristic tensile strength or diameter (i.e. with strands with $f_{pk} = 1770 \text{ N/mm}^2$ or $\varnothing 15.2$). The provisions for tendons with strands with a characteristic tensile strength $f_{pk} = 1860 \text{ N/mm}^2$ also apply to tendons with strands with $f_{pk} < 1860 \text{ N/mm}^2$.

The standard *prEN 10138-3: Prestressing steels - Part 3: Strand* gives the following nominal values for the prestressing strands composing the VSL system units:

- Elongation at maximal force: $\geq 3.5 \%$
- Relaxation at $0.70 f_{pk}$ after 1 000 hours: $\leq 2.5 \%$
- Relaxation at $0.80 f_{pk}$ after 1 000 hours: $\leq 4.5 \%$
- Fatigue behaviour ($0.70 f_{pk}$; 190 N/mm^2): $\geq 2 \times 10^6$ cycles
- Maximum D value of deflected tensile test: $\leq 28 \%$
- Modulus of elasticity E_p : $195\,000 \text{ N/mm}^2$

The actual modulus of elasticity of the strand, measured by the supplier and communicated at the time of its supply, shall be taken into account for calculation of the cable elongations. Individually sheathed and protected strands have the same mechanical properties as the bare strands.

With the strand characteristics defined in prEN 10138-3 and the values of tendon cross-sections A_p the maximum forces recommended by EN 1992-1-1 are:

$$P_{\max} = \min \{k_1 \cdot A_p \cdot f_{pk}; k_2 \cdot A_p \cdot f_{p0.1k}\}, \text{ with } k_1 = 0.8, k_2 = 0.9$$

$$P_{m0,\max} = \min \{k_7 \cdot A_p \cdot f_{pk}; k_8 \cdot A_p \cdot f_{p0.1k}\}, \text{ with } k_7 = 0.75, k_8 = 0.85$$

Where P_{\max} is the maximum force applied to a tendon and $P_{m0,\max}$ is the maximum value of the initial force immediately after load transfer to the anchorage.

In accordance with the requirements of EN 1992-1-1 temporary overstressing is permitted to a maximum force of $k_3 A_p f_{p0.1k}$ with $k_3 = 0.95$.

P_{\max} and $P_{m0,\max}$ can be increased in accordance with section 4 of EN 1992-1-1 if the actual values of the strand are $f_{p0.1k} / f_{pk} > 0.88$.

Taking $f_{p0.1k} = 0.88 f_{pk}$ the forces for the VSL PT system units are as follows:

VSL Post-Tensioning System

STRAND GRADE		Y1770 S7-15.7 $f_{pk} = 1\,770\text{ N/mm}^2$ $F_{pk} = 266\text{ kN}; F_{p0.1k} = 234\text{ kN}$			Y1860 S7-15.3 $f_{pk} = 1\,860\text{ N/mm}^2$ $F_{pk} = 260\text{ kN}; F_{p0.1k} = 229\text{ kN}$			Y1860 S7-15.7 $f_{pk} = 1\,860\text{ N/mm}^2$ $F_{pk} = 279\text{ kN}; F_{p0.1k} = 246\text{ kN}$		
Anchorage Type	Tendon Unit	A_p	P_{max}	$P_{m0,max}$	A_p	P_{max}	$P_{m0,max}$	A_p	P_{max}	$P_{m0,max}$
		mm ²	kN	kN	mm ²	kN	kN	mm ²	kN	kN
6-1	6-1	150	210.3	198.6	140	206.2	194.8	150	221.0	208.7
6-2	6-2	300	420.6	397.2	280	412.5	389.6	300	441.9	417.4
6-3	6-3	450	630.8	595.8	420	618.7	584.3	450	662.9	626.1
6-4	6-4	600	841.1	794.4	560	824.9	779.1	600	883.9	834.8
6-7	6-5	750	1 051.4	993.0	700	1 031.2	973.9	750	1 104.8	1 043.5
	6-6	900	1 261.7	1 191.6	840	1 237.4	1 168.7	900	1 325.8	1 252.2
	6-7	1 050	1 471.9	1 390.2	980	1 443.7	1 363.5	1 050	1 546.8	1 460.8
6-12	6-8	1 200	1 682.2	1 588.8	1 120	1 649.9	1 558.2	1 200	1 767.7	1 669.5
	6-9	1 350	1 892.5	1 787.3	1 260	1 856.1	1 753.0	1 350	1 988.7	1 878.2
	6-10	1 500	2 102.8	1 985.9	1 400	2 062.4	1 947.8	1 500	2 209.7	2 086.9
	6-11	1 650	2 313.0	2 184.5	1 540	2 268.6	2 142.6	1 650	2 430.6	2 295.6
	6-12	1 800	2 523.3	2 383.1	1 680	2 474.8	2 337.4	1 800	2 651.6	2 504.3
6-15	6-13	1 950	2 733.6	2 581.7	1 820	2 681.1	2 532.1	1 950	2 872.6	2 713.0
	6-14	2 100	2 943.9	2 780.3	1 960	2 887.3	2 726.9	2 100	3 093.6	2 921.7
	6-15	2 250	3 154.1	2 978.9	2 100	3 093.6	2 921.7	2 250	3 314.5	3 130.4
6-19	6-16	2 400	3 364.4	3 177.5	2 240	3 299.8	3 116.5	2 400	3 535.5	3 339.1
	6-17	2 550	3 574.7	3 376.1	2 380	3 506.0	3 311.2	2 550	3 756.5	3 547.8
	6-18	2 700	3 785.0	3 574.7	2 520	3 712.3	3 506.0	2 700	3 977.4	3 756.5
	6-19	2 850	3 995.2	3 773.3	2 660	3 918.5	3 700.8	2 850	4 198.4	3 965.1
6-22	6-20	3 000	4 205.5	3 971.9	2 800	4 124.7	3 895.6	3 000	4 419.4	4 173.8
	6-21	3 150	4 415.8	4 170.5	2 940	4 331.0	4 090.4	3 150	4 640.3	4 382.5
	6-22	3 300	4 626.1	4 369.1	3 080	4 537.2	4 285.1	3 300	4 861.3	4 591.2
6-27	6-23	3 450	4 836.3	4 567.7	3 220	4 743.4	4 479.9	3 450	5 082.3	4 799.9
	6-24	3 600	5 046.6	4 766.3	3 360	4 949.7	4 674.7	3 600.0	5 303.2	5 008.6
	6-25	3 750	5 256.9	4 964.9	3 500	5 155.9	4 869.5	3 750.0	5 524.2	5 217.3
	6-26	3 900	5 467.2	5 163.4	3 640	5 362.2	5 064.3	3 900.0	5 745.2	5 426.0
	6-27	4 050	5 677.5	5 362.0	3 780	5 568.4	5 259.0	4 050.0	5 966.1	5 634.7
6-31	6-28	4 200	5 887.7	5 560.6	3 920	5 774.6	5 453.8	4 200.0	6 187.1	5 843.4
	6-29	4 350	6 098.0	5 759.2	4 060	5 980.9	5 648.6	4 350.0	6 408.1	6 052.1
	6-30	4 500	6 308.3	5 957.8	4 200	6 187.1	5 843.4	4 500.0	6 629.0	6 260.8
	6-31	4 650	6 518.6	6 156.4	4 340	6 393.3	6 038.2	4 650.0	6 850.0	6 469.5
6-37	6-32	4 800	6 728.8	6 355.0	4 480	6 599.6	6 232.9	4 800	7 071.0	6 678.1
	6-33	4 950	6 939.1	6 553.6	4 620	6 805.8	6 427.7	4 950	7 291.9	6 886.8
	6-34	5 100	7 149.4	6 752.2	4 760	7 012.1	6 622.5	5 100	7 512.9	7 095.5
	6-35	5 250	7 359.7	6 950.8	4 900	7 218.3	6 817.3	5 250	7 733.9	7 304.2
	6-36	5 400	7 569.9	7 149.4	5 040	7 424.5	7 012.1	5 400	7 954.8	7 512.9
6-37	5 550	7 780.2	7 348.0	5 180	7 630.8	7 206.8	5 550	8 175.8	7 721.6	
6-43	6-38	5 700	7 990.5	7 546.6	5 320	7 837.0	7 401.6	5 700	8 396.8	7 930.3
	6-39	5 850	8 200.8	7 745.2	5 460	8 043.2	7 596.4	5 850	8 617.8	8 139.0
	6-40	6 000	8 411.0	7 943.8	5 600	8 249.5	7 791.2	6 000	8 838.7	8 347.7
	6-41	6 150	8 621.3	8 142.4	5 740	8 455.7	7 985.9	6 150	9 059.7	8 556.4
	6-42	6 300	8 831.6	8 340.9	5 880	8 661.9	8 180.7	6 300	9 280.7	8 765.1
6-43	6 450	9 041.9	8 539.5	6 020	8 868.2	8 375.5	6 450	9 501.6	8 973.8	
6-55	6-44	6 600	9 252.1	8 738.1	6 160	9 074.4	8 570.3	6 600	9 722.6	9 182.4
	6-45	6 750	9 462.4	8 936.7	6 300	9 280.7	8 765.1	6 750	9 943.6	9 391.1
	6-46	6 900	9 672.7	9 135.3	6 440	9 486.9	8 959.8	6 900	10 164.5	9 599.8
	6-47	7 050	9 883.0	9 333.9	6 580	9 693.1	9 154.6	7 050	10 385.5	9 808.5
	6-48	7 200	10 093.2	9 532.5	6 720	9 899.4	9 349.4	7 200	10 606.5	10 017.2
	6-49	7 350	10 303.5	9 731.1	6 860	10 105.6	9 544.2	7 350	10 827.4	10 225.9
	6-50	7 500	10 513.8	9 929.7	7 000	10 311.8	9 739.0	7 500	11 048.4	10 434.6
	6-51	7 650	10 724.1	10 128.3	7 140	10 518.1	9 933.7	7 650	11 269.4	10 643.3
	6-52	7 800	10 934.4	10 326.9	7 280	10 724.3	10 128.5	7 800	11 490.3	10 852.0
	6-53	7 950	11 144.6	10 525.5	7 420	10 930.6	10 323.3	7 950	11 711.3	11 060.7
	6-54	8 100	11 354.9	10 724.1	7 560	11 136.8	10 518.1	8 100	11 932.3	11 269.4
6-55	8 250	11 565.2	10 922.7	7 700	11 343.0	10 712.9	8 250	12 153.2	11 478.1	

Note: Values in bold correspond to full units of the VSL system.
 Prestressing force applied to structure must be in accordance with national regulations.

A.1.3 Anchorages

A.1.3.1 Presentation of the anchorages

The anchorages of the VSL Multistrand System are the following:

Type E, CS, GC, NC and NC-U active end anchorages

These active anchorages are designed to anchor the tendons at the stressing end. They are composed of an anchor head drilled with conical holes that house the permanent locking wedges.

The load is transferred from the anchor head to the structure by an E, CS, GC, NC or NC-U type anchor plate. Some of these anchor plates are connected to an E, CS or GC type trumpet that deviates the strands to the duct.

Type E, CS, GC, NC and NC-U passive end anchorages

These passive anchorages block the tendons at the passive end, where stressing is not carried out.

The E, CS, GC, NC and NC-U anchorages can be used with standard anchor heads and pre-clamped wedges that may be controlled during stressing.

Anchorage type E, GC, NC or NC-U can also be used with EP anchor heads. The EP anchor heads have cylindrical drillings and a flat bearing surface that supports swaged compression fittings. They can be embedded in concrete.

Type H bonded passive end anchorages

The H anchorages are used as dead end anchorages. The prestressing force is transferred to the concrete partially by bond of bare strands and partially by end bearing (bulb).

Type K fixed couplers

These anchorages are used for connection to a cable that has already been stressed.

The first-phase cable is anchored in the conical holes of the K fixed coupler, transferring the load to a type E, CS or GC anchor (transfer) plate. The second phase cable, on the coupler side, is anchored by means of compression fittings on slots in the periphery of the K coupler.

The two coupled tendons must be units of the same number of strands and the force in the second phase cable shall not be larger than the force in the first phase cable.

The coupling is then isolated from the concrete by means of a sleeve.

Type V movable couplers

These anchorages ensure the continuity of two lengths of a tendon which are stressed simultaneously.

The V type mobile couplers use a "movable" head similar to the previously described model K coupling the two cable sections inside a sleeve. The V coupling head has retaining plates to hold the compression fittings in position. The two coupled lengths must be units of the same number of strands. The coupling is isolated from the concrete by means of a sleeve.

A.1.3.2 List of approved anchorages

The units of the VSL Multistrand System covered in this ETA are:

ANCHORAGE		Active end					Passive end					Bond	Coupler		
CABLE	Unit	E	CS	GC	NC	NC-U	E	CS	GC	NC	NC-U	EP	H	K	V
		1	6-1	✓					✓						✓
2	6-2	✓					✓						✓		
3	6-3	✓		✓			✓		✓			✓	✓	✓	✓
4	6-4	✓		✓			✓		✓			✓	✓	✓	✓
7	6-7	✓	✓	✓			✓	✓	✓			✓	✓	✓	✓
12	6-12	✓	✓	✓			✓	✓	✓			✓	✓	✓	✓
15	6-15	✓		✓			✓		✓			✓	✓	✓	✓
19	6-19	✓	✓	✓			✓	✓	✓			✓	✓	✓	✓
22	6-22	✓	✓	✓			✓	✓	✓			✓	✓	✓	✓
27	6-27	✓	✓	✓			✓	✓	✓			✓	✓	✓	✓
31	6-31	✓	✓	✓			✓	✓	✓			✓	✓	✓	✓
37	6-37	✓	✓	✓			✓	✓	✓			✓	✓	✓	✓
43	6-43	✓		✓			✓		✓			✓			
55	6-55	✓		✓	✓	✓	✓		✓	✓	✓	✓			

Note: Strand can be type S7-15.3 or S7-15.7

The tendons of the PT system anchorages are stressed with the VSL stressing jacks, which are presented in [Clause A.4.1 - Stressing equipment](#). Other models of jacks could be used if they are approved by VSL.

A.1.4 Categories of use, possibilities and options

A.1.4.1 Uses and options of the VSL multistrand system

The tendons and anchorages of the VSL system may have the following basic use categories as per EAD 160004-00-0301 (see details on table below):

- Internal bonded tendon for concrete and composite structures (with anchors placed in concrete)
- Internal unbonded tendon for concrete and composite structures (with anchors placed in concrete)
- External tendon for concrete and composite structures
- Restressable tendon (internal or external)
- Internal tendon for cryogenic applications (with anchorages inside and outside the possible cryogenic zone)
- Internal bonded tendon with corrugated plastic duct
- Encapsulated tendon (leak tight)
- Electrically isolated tendon

The use categories above can be combined for particular applications, for instance as follows:

- External tendon with grouted duct
- External tendon with soft filler and duct
- External tendon using a bundle of individually greased and sheathed monostrands in HDPE duct with cementitious grout as filler
- External tendons using a bundle of individually adherent protected and sheathed strands

VSL Post-Tensioning System

These units may be:

- Adjustable (in force)
- Replaceable (if they are unbonded to the structure)

The type of anchorages and the possible categories of use are as follows:

ANCHORAGES	E	CS	GC	NC	NC-U	H	EP	K	V
internal* bonded cable with metallic duct	✓	✓	✓	✓		✓	✓	✓	✓
internal* bonded cable with polymeric duct	✓	✓	✓	✓		✓	✓	✓	✓
internal* unbonded	✓	✓	✓	✓	✓		✓	✓	✓
external* bonded cable with cementitious filler	✓	✓	✓	✓		✓	✓	✓	
external* unbonded cable with flexible filler	✓	✓	✓	✓			✓	✓	
tendon for use in various material as external cable	✓						✓	✓	
restressable tendon	✓	✓	✓	✓	✓				
exchangeable tendon	✓	✓	✓	✓	✓		✓		
cryogenic applications (inside and outside the possible cryogenic zone)	✓		✓				✓		
encapsulated tendon (leak tight)	✓	✓	✓	✓			✓	✓	✓
electrically isolated tendon	✓	✓	✓				✓	✓	

(*) internal/external to the concrete

Exchangeable tendons are unbonded to the structure. This is achieved by soft injection, by a double pipe at the anchorages and continuity of ducts through intermediate deviators in case of rigid injection or by the use of monostrands or individually adherent protected and sheathed strands. The clearance between the outside diameter of tendon duct and inside diameter of formwork pipe in the structure has to be enough to allow replacement.

The VSL Multistrand System may be used without injection of the interstices in the cable for temporary works or in non-aggressive environments.

Details of units or cable components can be found in the following clauses:

- For strands see [Clause A.2.1 - Strands used](#)
- For ducts see [Clause A.2.2 - Ducting](#)
- For anchorages see [Clause A.3.4 - Anchorage arrangements](#)
- For injection see [Clause A.5.2 - Injection products](#)

A.1.4.2 Possibilities of the VSL multistrand system

Partial stressing or stressing in stages

Stressing can be carried out in stages. Once the target force has been reached, pressure in the jack is released to get the wedges drawn into the anchor head to anchor the strands. At the end of each stressing phase, the wedges are locked inside their cavities, transferring the load from the jack to the anchorage. The procedure is the same in the case of long tendons, where the elongation is reached after several jack strokes.

Overstressing with shimming

At the time of load transfer, the wedges set inside their cavities. The draw in in the wedges reduces the elongation and create a tension loss on the stressing end. For some anchorages it is possible if required from a design point of view to compensate the draw in and adjust the tension to the desired value by using a jack chair ring and then installing split shims between the anchor head and the anchor plate (see [Clause A.2.6.3 - Setting of anchorage wedges](#)).

Destressing

It is possible to destress an anchorage with special tooling provided that the required strand overlength has been conserved and the tendon remains unbonded to the structure. The value of the overlength is given in [Clause A.6.9 - Block-out dimensions – Clearance requirements](#).

A.2 Strands and ducts

A.2.1 Strands used

Strands are presented in [Clause A.1.2 - Characteristics of system units](#). They shall comply with *prEN 10138-3: Prestressing steels - Part 3: Strand*. They may be "Y1860S7 – No. 1.1366" or "Y1770S7 – No. 1.1365".

Individually greased and sheathed monostrands can be used for unbonded tendons, either internal or external to concrete or other materials. They are compliant with EAD 160004-00-0301 or NF A 35-037-2, which specify the requirements, verification methods and acceptance criteria of both the grease and the sheathing.

Individually adherent protected sheathed strands complying with NF-A35-037-3 can only be used for unbonded tendons, if all strands including their sheathing can move relatively against the structure during prestressing (e. g. external to concrete or other materials).

A.2.2 Ducting

The VSL Multistrand System can use several types of duct that are described in this section. The duct type will depend on the project requirements, the final use of the structure and the type of post-tensioning units.

A.2.2.1 Types and dimensions of the usable ducts

Depending on the specific application and the required protection level 1, 2 or 3 (PL1 to PL3 as per *fib Bulletin 33 – Durability of post-tensioning tendons*), various types of ducts are used. From a general point of view the ducts must be able to define the specified cable profile (if they are embedded in concrete), provide leak tightness during filler injection and protect the strands against external corrosion attack (always required in the case of external cables). They need therefore to be mechanically resistant, display continuity in shape, ensure continuity at splices and, if required, provide electrical insulation over their entire length. They shall also provide an efficient bond to the structure (when this is required) and not cause any chemical attack to the prestressing steel.

The following table shows the type of ducts that is usually adopted for different applications:

VSL Post-Tensioning System

APPLICATIONS			DUCTS		Metal Ducts		Polymeric Ducts	
			Corrugated metal duct	Smooth metal duct	VSL PT-PLUS® Duct	Smooth polymeric duct (polyethylene, polypropylene)		
Internal Cable, in the concrete	with rigid filler providing bond	standard (PL1)	✓	NR	✓	NR		
		cryogenic	✓	NR	✓	NR		
		encapsulated (PL2)	NA	NR	✓ ⁽⁰⁾	NR		
		electrically-isolated (PL3)	NA	NA	✓ ⁽⁰⁾	NR		
	with flexible filler ⁽²⁾	standard (PL1) + encapsulated (PL2)	NA	✓	NR	✓		
		electrically-isolated (PL3)	NA	NA	NR	✓		
restressable and/or replaceable		NA	✓	NR	✓			
External Cable, out of the concrete (or other material)	with rigid filler	standard (PL1) + encapsulated (PL3)	NA	✓ ⁽¹⁾	NR	✓		
		electrically-isolated (PL3)	NA	NA	NR	✓		
	with flexible filler ⁽²⁾	standard + encapsulated	NA	✓ ⁽¹⁾	NR	✓		
		electrically-isolated (PL3)	NA	NR ⁽³⁾	NR	✓		
		restressable and/or replaceable	NA	✓ ⁽¹⁾	NR	✓		
For the other materials such as masonry, wood, etc., refer to conditions relative to concrete and take into account the installation constraints. NOTES: General Protection levels (PL1, PL2 and PL3) as per <i>fib Bulletin 33-Durability of post-tensioning tendons</i> ⁽⁰⁾ This set-up features a fully-bonded cable. ⁽¹⁾ Smooth ducts in polyethylene or polypropylene are the most common. ⁽²⁾ Strands defined in chap. 2.1, i.e. bare strands with total injection of duct with flexible filler or individually protected and sheathed monostrands with a rigid filling of the duct. ⁽³⁾ Using monostrands.								
✓: Recommended			NR: not recommended			NA: not allowed		

The ducts of the VSL Multistrand System, for the most part with a circular cross-section, must be large enough to allow for easy installation of the strands and adequate injection of the protective filling product.

VSL recommends an internal duct diameter $\varnothing_{int} \geq 1.8 \sqrt{A_p}$, where A_p is the nominal cross-section of the strands composing the unit. This relation is suitable for the usual case of tendons with strands pushed inside the duct prior to concreting. In the case of prefabricated cables, it is possible to adopt a duct with a smaller diameter. For the calculations, it is necessary to consider the distance (eccentricity) between the centre of the duct and the centre of gravity of the strand bundle.

The recommended duct dimensions and the eccentricity values are given in [Clause A.6.11 - Ducting](#).

The ducts may be supplied in coils or straight segments.

A.2.2.2 Metal ducts

The tendons are most often isolated from the concrete by means of corrugated steel strip sheaths. This corresponds to a standard protection level PL1 as defined by *fib Bulletin*. According to standard EN 523, that defines their characteristics, they may be either "normal sheaths" (Category 1), or "rigid sheaths" (Category 2, still bendable by hand).

The connections between coils or straight segments are made by a connector (coupler) that is threaded to the two extremities to be connected. The joints are sealed by either adhesive tape or thermo-retractable sleeves.

In certain applications (e.g. nuclear, offshore), the tendons are encased in smooth steel ducts (tubes). The most frequently used tubes, whether welded or not, are thin (in compliance with the EN standards) and machine-bendable. One of their extremities has usually a bell mouth shape that allows to connect the segments. The connections are sealed by fillet welds, thermo-retractable sleeves or adhesive tape.

A.2.2.3 Polymeric ducts

In the case of stringent requirements regarding the corrosion protection (PL2 and PL3 as per *fib Bulletin 33*) and the fatigue resistance of cables, VSL recommends to use the corrugated polymeric duct VSL PT-PLUS®. This duct is only used for internal PT inside concrete in combination with a cementitious filler. It provides perfect bond between the tendons and the structure.

The VSL PT-PLUS® duct complies with EAD 160004-00-0301. The duct segments are connected by mirror welding or by connectors that provide for both the waterproofing seal and electrical isolation. Rigid half-shell supports are installed at the high points of the cable path in order to avoid damages during tendon stressing if its radius is less than two times the minimum permissible radius of curvature.

This type of duct can be used with all anchorage types E, EP, CS, GC, NC, NC-U, H, K and V. When used with CS-type anchorages, it creates fully-encapsulated units CS-PLUS (PL2 as per *fib Bulletin 33*) and electrically isolated units CS-SUPER (PL3). The VSL PT-PLUS® duct can also be used with E, K and GC type anchorages to obtain encapsulated (PL2) and electrically isolated tendons (PL3) if the anchorages are equipped with plastic trumpets over their full length.

Ducts of internal prestressing crossing over match-cast precast segmental joints have to be spliced by segmental couplers to ensure PL2 or PL3 protection levels. They consist of a face seal ring that is compressed during the joining of segments against cast in bearing surfaces in plastic on both segment end faces.

For design in accordance with EN-1992 it can be assumed that tendons with VSL PT-PLUS® polymeric ducts have a 50 % longer bond length than tendons with corrugated metal ducts.

Common ducts (sleeves or tubes) made of polyethylene or polypropylene can also be used. The connections between the segments are usually carried out by mirror welding or electrofusion couplers. Polymeric pipes shall comply with EAD 16004-00-0301 (for more details see [Clause A.6.11 - Ducting](#)). With an appropriate set of fittings, they may be used for encapsulated (PL2) and electrically-isolated tendons (PL3).

A.2.2.4 Accessories for inlets, bleed vents and outlets

Accessories for venting and if required for inlet and outlet of grout are fixed to the ducts along the cable path in order to obtain complete filling of the cables. These accessories include shells or collars fastened to the ducts and connected to tubes that are accessible from the outside. The following options are available:

Duct	Duct connection accessory	Venting accessory
Corrugated steel strip sheath	Sealed polymeric shell	Polymeric pipe
Smooth steel tube	Welded pipes	Steel tube or polymeric pipe
VSL PT-PLUS® duct	Couplers with grout vent	Polymeric pipe
Polymeric duct	Electro-weldable collar or welded pipes	Polymeric pipe

The position of inlet, venting and outlet points along the cable profile is defined by the design.

A.2.2.5 Connection with trumpets

The strands are deviated by a trumpet at the transition between the duct and the anchor head. This trumpet is considered a part of the anchorage.

The seal between the duct and trumpet is carried out with adhesive tape, thermo-retractable sleeves or duct accessories (e.g. a VSL PT-PLUS® coupler).

A.2.3 Cable layout

The cable layout is defined by the project.

A.2.3.1 Straight lengths behind the anchorages

For standard anchorages without XT-deviators, the following values shall be respected for the straight length L_{min} . They include both the anchor plate and the trumpet:

For $F_{pk} < 2$ MN	$L_{min} = 0.8$ m
For 2 MN $\leq F_{pk} \leq 7$ MN	$L_{min} = 1.0$ m
For $F_{pk} > 7$ MN	$L_{min} = 1.5$ m

For external PT refer to [Clause A.2.3.2 - Radius of curvature](#).

A.2.3.2 Radius of curvature

The minimum radii of curvature for internal bonded tendon shall comply with EAD 160004-00-0301. In case there is no national regulation for radii of curvature the following values are advised for internal bonded tendons with strands grade Y1770S7 or Y1860S7 according to prEN10138-3 and cross-sectional area 139 to 150 mm²:

$$R_{min} = \frac{2F_{pm0} d_{strand}}{p_{R,max} d_{duct,i}} \geq 2,5 \text{ m}$$

Where

R_{min}	minimum allowable radius of curvature
F_{pm0}	initial prestressing force of the tendon
d_{strand}	diameter of strands
$p_{r,max} = 130, 150$ or 230 kN/m	recommended maximum allowable pressure under critical strand in the absence of national regulations
$d_{duct,i}$	internal diameter of circular duct

For usual cases, the following simplified formulae can be recommended:

For corrugated steel strip sheaths of Category 2 (see [Clause A.2.2.2 - Metal ducts](#)):

$$R \geq 100 \varnothing_{int} \dots \dots \dots [1]$$

Where R is the radius of curvature and \varnothing_{int} = internal diameter of the duct.

For corrugated steel strip sheaths of Category 1 (see [Clause A.2.2.2 - Metal ducts](#)), VSL PT-PLUS ducts (see [Clause A.2.2.3 - Polymeric ducts](#)) and smooth steel tubes:

$$R \geq \max\{2.8\sqrt{F_{pk}} ; 2.5 \text{ m}\} \dots \dots \dots [2]$$

Where R is expressed in meters and F_{pk} , breaking load of the cable, is expressed in MN.

VSL Post-Tensioning System

With the proposed dimensions of ducts (see [Clause A.6.11 - Ducting](#)) the formula [1] corresponds to a pressure around 140 kN/m, while the formula [2] corresponds to around 200 kN/m.

In some particular cases involving the use of smooth steel tubes, the radius of curvature may be significantly reduced to a value $R \geq 20 \varnothing_{int}$. In this case, local concrete strength as well as stresses in strands must be verified.

In all cases, it has to be checked that the tendon radius R_{actual} , derived from combined curvatures in elevation and plan, if applicable, is bigger than R_{min} :

$$R_{actual} \sim \frac{1}{\sqrt{\left(\frac{1}{R_{elevation}}\right)^2 + \left(\frac{1}{R_{plan}}\right)^2}}$$

Tendon sections may be curved in a U-shape at a tight radius to form a passive inaccessible end. These sections of the tendon are usually named “loop anchorages” (although they are not considered an anchorage by EAD 160004-00-0301) and they respect the following details:

- The duct in the loop is either smooth or corrugated and the diameter one size larger than in the free length for ease of connection (one fitting into other).
- The radius of curvature in the loop is $R \geq \max \{0.6\sqrt{F_{pk}}; 0.6 \text{ m}\}$, where R is expressed in meters and F_{pk} expressed in MN.
- The tendon is stressed simultaneously from both ends.
- The tendon is mainly subject to static load (no significant fatigue load).

For external post-tensioning (to concrete), a high-quality polyethylene tube shall be used with the adequate thickness for external cable as defined in Annex D of EAD 160004-00-0301. For standard tendons (not using XT-pads) the following values of the minimum radii shall be respected:

Tendon Unit	Deviator zones [m]	Anchorage zone [m]
6-3 to 6-7	2.0	3.0
6-12	2.5	3.5
6-15	3.0	4.0
6-19	3.0	4.0
6-22	3.5	4.0
6-27	3.5	4.5
6-37	4.0	5.0
6-43	4.5	5.5
6-55	5.0	6.0

The tendon’s radius R_{actual} derived from combined curvatures in elevation and plan, if applicable, should be bigger than R_{min} :

$$R_{actual} \sim \frac{1}{\sqrt{\left(\frac{1}{R_{elevation}}\right)^2 + \left(\frac{1}{R_{plan}}\right)^2}}$$

The trumpet length of the anchorage is sufficient to serve as the required straight length behind the anchorage provided that the curvature of the tendon behind the trumpet has the minimum radius

given above and the steel pipe has been pre-bent to this anchorage zone radius in a workshop ensuring tight tolerances.

Machine-bent smooth steel pipes can only be bent to a constant radius in one plane. The designer should take this into account when specifying the tendon profile.

Unintentional deviations or small intentional deviations of not more than 2 degrees are permitted for external tendons made out of individual sheathed monostrands up to 6-31. These small deviations can be accommodated with a flat saddle (no curvature and maximum angle of 2° at each side of the saddle). Small deviations up to 10° can be accommodated with a curved saddle. The dimensions of both types of saddles are shown in [Clause A.6.2.5 - Anchorages type E-WTe \(External unbonded tendons\)](#).

Intentional deviations of up to 3° plus additional unintentional deviations of 0.5° are permitted for tendons up to 6-31 with the use of individually adherent protected sheathed strands complying with NF-A35-037-3 supported by deviators based on the VSL XT-pads compact or XT-pad parallel (or a multiple of this intentional deviation with a succession of XT-pads taking up to 3° each). The intentional deviation is limited to 2° per XT-pad super compact. The dimensions and types of XT-deviators are shown in [Clause A.6.2.5 - Anchorages type E-WTe \(External unbonded tendons\)](#) and [Clause A.6.10 – XT-Deviators](#).

The XT-deviators guide each strand individually. The successive XT-pads can be placed adjacent to each other, resulting in a minimum radius of 1150 mm in case of using parallel or compact XT-pads (1720 mm in case of using super compact XT-pads).

If national regulations exist, radius of curvature must comply with them.

A.2.3.3 Spacing of the supports and tolerances

The position of the supports under the duct is defined in the design. It is usual to install them approximately every meter for a large radius of curvature and every fifty centimetres for a small radius of curvature in order to obtain the required geometry.

The ducts and tendons are firmly fastened to their supports at a distance that prevents excessive displacements or deformations. The recommended spacing of tendon supports is 10 to 12 times the duct diameter.

The tolerances on cable positions in the concrete elements must comply with EN 13670. Transverse fixation elements can be used to avoid undesired movements of external tendons.

Whenever a cable is or may be deviated in the vicinity of an edge of concrete which could lead to spalling of concrete cover, additional rebar shall be designed and installed in the structure.

A.2.3.4 Strand cut length

The total strand length shall be defined by adding the length of the post-tensioning tendon between the anchorages to the thickness of the anchor heads and the stressing overlength (crossing the stressing jack). These overlengths are given in [Clause A.6.9 – Block-out dimensions – Clearance requirements](#).

A.2.4 Installation of ducts and strands

Depending on the conditions of the project, one of the following solutions is adopted in the usual case of an internal post-tensioning of a new concrete structure:

- Cables (both strands and ducts) prefabricated off the structure and then delivered to the worksite as one unit for installation into the structure
- Strand bundles fabricated off the structure and then pulled into the ducts, which have been installed in the structure, before or after concreting
- Pushing of individual strands through the ducts, which have been installed in the structure, before or after concreting

A.2.5 Provisional protection and lubrication

The oiling or greasing of strands is carried out with non-dangerous substances in order to:

- Provide provisional protection against corrosion from the time of leaving the plant until permanent protection has been achieved (grouting of the cable)
- Lubricate and reduce the friction loss during stressing

With this same objective, other products may be used to reduce friction losses, provided that they are non-dangerous, can be easily applied and remain inert in the presence of permanent protection (and the eventual bond to the structure). For bonded post-tensioning the only products that can be used are those which do not have to be removed prior to grouting.

In addition, these products shall comply with the regulations of the place of use.

A.2.6 Calculation elements

A.2.6.1 Friction losses

The friction between strands and ducts, which occurs during stressing, reduces the effective post tensioning force in the strands along the cable path. This force, according to EN 1992-1-1, is expressed by the formula

$$P_{m0}(x) = P_{m0}(0) e^{-\mu (\theta+k x)}$$

Where

- $P_{m0}(x)$ post tensioning force at a distance x of the stressing end at the time of stressing
- $P_{m0}(0)$ post tensioning force of the cable at the stressing end (with $x=0$) at the time of stressing after friction losses of the active anchorage, also called design of stressing force (specified by the designer)
- μ friction coefficient between the strands and the duct
- θ cumulated angular deviations of the cable over the distance x
- k wobble coefficient, unintentional angular displacement for internal tendons(per unit length)

It is recommended to adopt the following numerical values for the parameters μ and k given in EN 1992-1-1:

Application	μ (rad ⁻¹) (1)		k (rad/m) (2)	
	Range	Recommended value	Range	Recommended value
Internal bonded tendon with corrugated steel strip sheath (bare strand)	0.16-0.22	0.18	0.004-0.008	0.005
Internal bonded tendon with smooth steel tube	0.16-0.24	0.20	0.005-0.010	0.007
Internal bonded tendon with VSL PT-PLUS duct (bare strand)	0.10-0.15	0.12	0.004-0.010	0.005
External tendon with smooth steel tube	0.16-0.24	0.20	0	0
External tendon with polymeric duct	0.10-0.14	0.12	0	0
Internal unbonded tendon with individually greased and sheathed strands	0.04-0.07	0.05	0.004–0.006	0.005
External tendon with individually greased and sheathed strands	0.04-0.07	0.06	0	0
External tendon with individually sheathed and protected adherent strands with polymeric pad (deviators E-WTe) or XT-deviators (XT-pads with buffer tubes) at deviation points	0.05-0.10	0.08	0	0

(1) The interval limit values encompass both lubricated and non-lubricated strands.

(2) The values of k are zero for cables outside the concrete.

A.2.6.2 Basis for evaluating elongations

The elongation after stressing is calculated from the post tensioning force diagram (post tensioning force in the strands $P_{m0}(x)$ plotted along the cable axis) before load transfer from the stressing jack to the anchorage

The total elongation on the live end that is measured at the back of the jack, where $x = -L_j$ may be written as follows

$$\Delta l = \underbrace{\int_{-L_j}^0 \frac{P_{m0}(x)}{A_p E_p} dx}_{\text{Elongation of tendon in the stressing jack}} + \underbrace{\int_0^{L_a} \frac{P_{m0}(x)}{A_p E_p} dx}_{\text{Elongation of tendon in the prestressed element}} + \underbrace{\int_0^{L_a} \frac{\sigma_c(x)}{E_{cm}} dx}_{\text{Concrete shortening of the prestressed element}} + \underbrace{g'}_{\text{Displacement of the dead end of the tendon}}$$

Where:

- A_p cross section of the prestressing tendons at the location x
- E_p modulus of elasticity for the prestressing steel
- $P_{m0}(x)$ initial prestressing force in the strands at a distance x at time $t=t_0$
- L_j length of the strands in the stressing jack. The value of the tensile stress of the strand inside the jack can be considered to be constant [$P_{m0}(-L_j) \sim (1 + k_a) \cdot P_{m0}(0) = \text{constant}$], with $k_a =$ friction loss in the stressing anchorage
- σ_c concrete compressive stress
- E_{cm} modulus of elasticity for the concrete
- L_a calculation length of the tendon. It corresponds to the length of the cable from the live end anchorage to the section where $P_{m0}(x)$ is minimum (usually the dead end)
- g' wedge draw in at the tendon's passive anchorage (if applicable)

The value of the concrete shortening is negligible in the majority of cases (except if stresses in the concrete resulting from prestressing are high).

If the cable has a passive anchorage, which is accessible and whose wedges are manually pre-set (common case), a draw-in g' of 3 mm can be considered.

If $P_{m0,av}$ is the average force over the concerned strand length, the following simplified expression can be used:

$$\Delta l = \frac{(1 + k_a) P_{m0}(0)}{A_p E_p} L_j + \frac{P_{m0,av}}{A_p E_p} L_a + g'$$

Elongation due to tendon slack should be eliminated from the reported value with appropriate procedures (e.g. starting the measurement of the elongation only once the tendon has been stressed to e.g. 25 % of $(1 + k_a) P_{m0}(0)$, that is taking after the tendon has been straightened inside its duct).

Note: The values k_a of the friction losses in the anchorages are given in [Clause A.4.2.1 - Force measurement](#).

A.2.6.3 Setting of anchorage wedges

The value of the wedge draw-in is 6-mm and it remains constant for all anchorages and wedges.

The wedge draw-in can, if required, be fully or partially compensated by split shims of the suitable thickness inserted between the anchor head and its anchor plate. In any case, the initial tensioning force (higher than the final target force) shall not exceed P_{max} , which is the maximum force authorized during unit stressing.

The split shim is made of same material as the anchor plate E and the diameter of the hole is the same as specified for the E or CS plate.

Note: compression fittings are without significant setting.

A.3 Anchorages

A.3.1 Description of anchorage components

The VSL Multistrand System anchorages make use of a set of standard elements that are described as follows:

A.3.1.1 Live end / dead end Anchorages

Live end (active) and dead end (passive) anchorages of the VSL Multistrand System comprise:

Anchor plates and trumpets

The types of the anchorages or bearing plates and trumpets covered by this ETA are as follows:

- **E.** The bearing plate is made of steel according to EN 10025-2 or GB/T 1591. The E trumpet is made of steel sheet.
- **CS.** The CS bearing plate is made out of cast iron according to EN 1563 and a very high-strength mortar. The CS trumpet is made of polymeric material and can be connected by the appropriate element to the VSL PT-PLUS® duct. The CS trumpet can also be combined with E anchor plate.
- **GC.** The GC bearing plate is made out of cast iron according to EN 1561 or EN 1563. For small units (3 to 15) the deviation is created in the casting without trumpet. For greater units (19 and above), the GC trumpet is made out of polymeric material.

- **NC** and **NC-U**. The NC casting is made out of cast iron according to EN 1563 and a polymeric insert. The NC-U type is used with sheathed strands.

Anchor heads

The anchor heads covered by this ETA are the following:

- **E** and **EP**. They are used with the bearing plates type E, GC, NC or NC-U. These anchor heads are machined from a steel rod according to EN ISO 683-1, EN ISO 683-2, GB/T 3077 or GB/T 17107. Two series of anchor heads E and EP are available. They are designated E and E(QT) or EP and EP(QT). Unless otherwise mentioned, in the rest of this document the term E is used to cover both the E and the E(QT) anchor heads. Similarly, the term EP is used for both the EP and EP(QT) anchor heads. E-anchor heads may be equipped with an oversized external thread for load monitoring.
- **GC**. The GC anchor heads are used with the GC bearing plates for internal, external or electrically isolated tendons. They are machined from a steel rod according to EN ISO 683-1, EN ISO 683-2, GB/T 3077 or GB/T 17107
- **CS**. The CS anchor heads are used with the plates CS. They are machined from a steel rod or forged material according to Standard EN ISO 683-1 or EN ISO 683-2.

The anchor heads are CNC machined and exhaustively controlled.

Anchorage used with protected and sheathed monostrands (either adherent or sliding) include a sealing between anchor head and monostrands to encapsulate the strands in the anchorage zone. In particular, the E anchorages can be used for external tendons made out of individual sheathed and protected monostrands. In this case, the system is called **E-WTe**, and it is formed by E-type anchor heads and additional components to obtain full encapsulation of the tendons.

Bond anchorages type H

The anchorages type H are dead end anchorages with a defined geometry that transfer the prestressing force to the concrete partially by bond and partially by end bearing (bulb). Units covered by this ETA range from 6-1 to 6-37 (see [Clause A.6.6 – Anchorages type H](#)).

Wedges

The wedges are made out of alloyed steel for cementation according to EN ISO 683-3 or GB/T 3077 and GB/T 5216, then threaded, cut and heat treated. These wedges are all submitted to stringent controls. The wedges used for multistrand post-tensioning included in this ETA are:

- **W6N** and **W6S** wedges, with two independent parts. They are used with either 0.6" or T15.2 strands (type W6N) or 0.6"S or T15.7 strands (type W6S). To be able to differentiate visually the W6N (normal wedges) from the W6S (super wedges), the S wedges have a groove on the front face.
- **W6N-C** and **W6S-C** wedges. They are fabricated with a clip and are used with 15.2 mm or 15.7 mm strand respectively.

The W6N and W6S wedges of the VSL Multistrand System can also be used for the VSL Slab System (see [Clause B.3.1 – Description of anchorage components](#)).

Compression fittings

The compression fittings CFE6 are used with EP, K and V anchorages. They are formed by a barrel made out of unalloyed steel according to EN 683-1 and an insert type CF6 or CF6N for use with 15.7 or 15.2 respectively.

Protective caps

Three types of protection caps are used in order to protect the anchorage and allow for injection:

- Temporary or provisional caps. They are designed to seal the anchorage during the injection of the cementitious filler (grout) for the permanent protection of the cable. After the grout has set, these caps are recycled for reuse. The injection product must be a rigid grout and the anchorage block-out must be filled with concrete.
- Permanent steel caps, sealing the anchorage during the injection of the cementitious filler (grout), which are left in place after injection.
- Permanent polymeric caps, sealing the anchorage during the injection of the cementitious filler (grout), which are also left in place after injection. This cap has been designed in particular for sealed and electrically isolated cables.

Caps need always to have a venting port to be able to fill them completely during injection. Caps must be permanent in case of use of a flexible filler to protect the cables against corrosion.

Permanent polymeric caps can be left exposed. Permanent steel caps can be left exposed if adequate precautions are taken against corrosion of the metallic parts. Permanent caps can also be used as temporary caps.

Permanent caps for minimum overlength of strands are shown on [Clause A.6.1.5 – Protective caps for anchorages](#). Longer permanent caps may be used to permit longer overlength of strands in case of adjustable and de-stressable tendons.

A.3.1.2 Couplers

The couplers type K (fixed) or V (movable) are made out of the same material as the E anchor heads. They have conical holes to house the wedges of the first phase cable and slots to position compression fittings for connection of the strands of the second phase cable. Each compression fitting is composed of a spiral and a sleeve that are swaged (extruded) on the extremity of the strand.

A.3.1.3 Delivery to site and sequence of operations

In the usual case (internal post-tensioning of a new concrete structure with the strands installed after concreting), the sequence of operations is as follows:

1. Delivery to the jobsite of the anchor plates and the ducts for placement within the passive reinforcement, and fastening of the anchor plates to the formwork. These anchorage parts are delivered tagged for identification either on pallets or in bulk.
2. Delivery to the jobsite of the anchor heads and wedges. Installation of the strands inside the ducts (before or after concreting), installation of the anchor heads, setting of the wedges, stressing, installation of temporary or permanent caps and grouting of the permanent cable protection. These anchorage components are delivered tagged for identification, packaged and protected (the same applies for the strands).

A.3.2 Quality organization

The fabrication of the anchorage components of the VSL Multistrand System is conducted in compliance with the specifications, production and control procedures laid out in the present ETA and associated documents.

The Factory Production Control implemented by the Component Manufacturers and the quality organization of the PT Specialist Company serve to ensure the traceability of the components until they are delivered and installed on the jobsite.

A.3.3 Installation of VSL anchorages

The installation of the VSL anchorages is done as described below. It shall be assigned to competent staff members within the PT Specialist Company or to well-trained PT Supervisors.

The most usual case (internal post-tensioning of a new concrete structure) is presented:

A.3.3.1 Type E, CS, GC, NC and NC-U active end anchorages

The anchor plates and trumpets are attached to the formwork and connected to the ducts which have been placed at the time of installation of the passive reinforcement. They are embedded in the structure or structural element upon concreting.

The E plates may also be installed on a previously-completed concrete facing. In this case, it may be necessary to apply a grout between the plate and the concrete facing to ensure full contact over the entire bearing area. They may also be installed on a metallic surface.

Split shims might be used between the E plate and the E or EP anchor heads in order to allow for the installation of pre-fabricated strand bundles with anchor block attached.

The CS, GC, NC and NC-U plates have to be embedded in concrete and hence need always to be installed prior to concreting.

The position of the injection holes depends on the type of anchorage, the structure and the accessibility during injection. The vents can exit on the front face of the anchorage or use tubes in order to exit the structure.

The anchor heads and wedges are positioned only shortly before stressing in order to avoid damages of these components.

In the case of unbonded tendons embedded in concrete, the monostrands are initially tensioned to a low force to remove slack. Then the free length is filled with cementitious grout to fill the interstices between the individual strands and the duct. To achieve this, the duct is sealed on both ends at the anchor plates. Once the grout has attained sufficient strength ($f_{c,min(t)} \geq 20/25 \text{ N/mm}^2$), the monostrands are stressed to their final force.

The electrically isolated tendons (PL3), such as the CS-SUPER or the GC-EIT units have isolating plates (to be inserted between the head and plate) and isolating polymeric caps. The E anchorages can also be used for electrically isolated tendons by using a polymeric trumpet and an isolating plate.

The force losses of the anchorages are described in [Clause A.4.2.1 – Force measurement](#).

A.3.3.2 Type E, CS, GC, NC and NC-U passive end anchorages

The installation of these anchorages is carried out as described in [Clause A.3.3.1 - Type E, CS, GC, NC and NC-U active end anchorages](#).

Once the anchor head has been installed, before stressing at the other end, the wedges are pre-locked using a wedge tool and then remain accessible throughout the stressing phase for observation.

When there is no access to the passive anchor head during stressing the wedges must be locked in their cavities by power seating. As an alternative, an EP anchor head may be used. In an EP anchor head the strands are not blocked in the anchor head with wedges but are fitted with compression fittings before concreting. After the compression fitting have been swaged onto the ends of the strands, the strands are pulled against the EP anchor head until the compression fittings are in contact with the EP anchor head. Subsequently a retaining plate is installed to hold the compression fittings in position during concreting. These anchorages may of course also be used if the anchor head is not embedded in concrete.

Split shims may be used between the E plate and the E or EP anchor heads in order to allow the installation of pre-fabricated strand bundles with anchor block attached.

Passive end anchorages (with wedges or compression fittings) can also be used for electrically isolated tendons.

A.3.3.3 Type H bond anchorage

The load transfer to the structure is made partially by bond of the strands and partially by end bearing (bulb).

At the end of the strands, the strands with the bulbs are spaced correctly by provision of a positioning grids. If required, the duct end is reinforced with a ring, which can take the strand's deviation forces by a hoop tensile force.

The entire anchorage assembly is solidly fastened to the passive reinforcement. After the installation of the injection tube, the extremity of the duct is sealed.

The strand ends have to be properly degreased on the bond length. Concrete around the anchorages is carefully placed and vibrated with aggregate whose diameter does not exceed 30 mm.

A.3.3.4 Type K fixed coupler

The installation of the K coupler is carried out as presented in [Clause A.3.3.1 - Type E, CS, GC, NC and NC-U active end anchorages](#) for the live end anchorages.

For the passive part of the coupling, the installation takes place prior to concreting the second phase of the structure. The strands exiting the duct are deviated through a ring towards the K anchor head and they are fitted with compression fittings that are placed into the peripheral slots of the K coupler. A strapping holds the fittings in position and a trumpet/sleeve (made of either sheet metal or polymeric material) isolates the coupler from the concrete.

A vent at the apex of the trumpet/sleeve allows to fill the anchorage zone with grout.

For electrically isolated tendons, in addition to specific arrangements of [Clause A.3.1.2 - Couplers](#), the K coupler requires an isolation plate to be installed between coupling head and the bearing plate.

A.3.3.5 Type V movable coupler

When a cable is composed of more than one length of strands without intermediate stressing, the K head defined in [Clause A.3.1.2 - Couplers](#) is used as movable coupler to splice between the lengths of strands. The size of the sleeve is defined to allow free movement of the coupler head during stressing.

A.3.4 Anchorage arrangements

For the categories of use described in [Clause A.1.4.1 – Uses and options of the VSL multistrand system](#), the following arrangements of anchorage components can be used:

Anchorage	Components	Uses										
		internal bonded cable with metal duct	internal bonded cable with polymeric duct	internal unbonded	external cable with cementitious filler	external cable with flexible filler	tendon for various material (ext. cable)	restressable tendon	Cryogenic applications	exchangeable tendon	encapsulated tendon (leak tight, PL2))	electrically isolated tendon (PL3)
E	Plate	E	E	E	E	E	E	E	E	E	E	E
	Head(8)	E	E	E	E	E	E	E	E	E	E	CS
	Trumpet(9)	E	E	E	E	E(9)	E(9)	E	E	E	E	CS(1)
	Cap	T(2)	T(2)	PM(3)	PM(3)	PM(3)	PM(3)	PM(4)	T(2)	PM(4)	PM(3)	PP
CS	Plate	CS	CS	CS	CS	CS		CS		CS	CS	CS
	Head	CS	CS	CS	CS	CS		CS		CS	CS	CS
	Trumpet	CS	CS	CS	CS	CS		CS		CS	CS	CS(1)
	Cap	T(2)	T(2)	PP(3)	PP(3)	PP(3)		PP(4)		PP(4)	PP	PP
GC	Plate	GC	GC	GC	GC	GC		GC	GC	GC	GC	GC
	Head(8)	E	E	E	E	E		E	E	E	E	E
	Trumpet	GC	GC	GC	GC	GC		GC	GC	GC	GC	GC(1)
	Cap	T(2)	T(2)	PM(3)	PM(3)	PM(3)		PM(4)	T(2)	PM(4)	PM(3)	PP
NC	Plate	NC	NC	NC	NC	NC		NC		NC	NC	
	Head(8)	E	E	E	E	E		E		E	E	
	Cap	T(2)	T(2)	PM(3)	PM(3)	PM(3)		PM(4)		PM(4)	PM(3)	
H		H	H		H							
K	Plate	(5)	(5)	(5)	(5)	(5)	(5)				(5)	(5)
	Coupler Head	K	K	K	K	K	K				K	K
	Trumpet	(5)	(5)	(5)	(5)	(5)	(5)				(5)	(5)
	Trumpet sleeve	M(6)	M(6)	M(6)	M(6)	M(6)	M(6)				M(6)	P(7)
V	Coupler Head	V	V	V	V	V	V				V	
	Trumpet sleeve	M(6)	M(6)	M(6)	M(6)	M(6)	M(6)				M(6)	

- Notes:
- 1: An insulation plate is installed between the bearing plate and the anchor head or coupler
 - 2: A temporary or provisional cap (T for Temporary) or Permanent (P) cap can be used
 - 3: Permanent Metallic (PM) or Permanent Polymeric (PP) cap
 - 4: Permanent Metallic (PM) or Permanent Polymeric (PP) cap with additional length to allow re-tensioning
 - 5: An E, CS or GC anchor plate and trumpet can be used
 - 6: An metallic (M) or polymeric (P) sleeve can be used
 - 7: Polymeric (P) sleeve
 - 8: EP anchor heads can replace E anchor heads on the passive end
 - 9: Trumpet is replaced by a guide tube (recess pipe) for the E-WTe configuration

A.3.5 Geometrical and mechanical use conditions

A.3.5.1 Clearance behind stressing anchorages

It is necessary to respect a clearance behind the anchorages in order to be able to install the stressing jacks. The dimensions are given in [Clause A.6.9 – Block-out dimensions – Clearance requirements](#).

These dimensions have to be increased in case of use of destressing or overstressing equipment. Check with VSL for more details.

A.3.5.2 Concrete strength, cover and anchorage spacing

The post-tensioning forces are transferred to the structures in the anchorage zones. The introduction of these forces to the concrete structure has the following implications:

- A minimum distance has to be respected between adjacent anchorages (distance centre to centre) and from an anchorage to the edge of the structure. These distances are given in the [Clause A.6](#) for the different types of anchorages and units.
- A local zone reinforcement (LZR) has to be installed below the anchorages. This LZR, which is an integral part of the anchorage, has to be defined as a function of the concrete strength at the time of stressing, the breaking load of the cable, the tensile strength of the passive steel and the type of anchorage used. See section 3.6 for more details.
- The concrete in the vicinity of the plates must be well compacted and vibrated and achieve the required minimum strength at the time of stressing .
- A general distribution zone behind the anchorages, called secondary prism, must be designed and detailed by the engineer of record to ensure that the post tensioning forces introduced into the structure at the anchorages can be distributed over the full cross sectional depth of the structure without overloading the concrete and the passive steel according to applicable design rules.

The maximum values for the force applied to the tendon (P_{max}) and the maximum value after load transfer to the anchorage ($P_{m0,max}$) are given in [Clause A.1.2 – Characteristics of system units](#).

The dimensions and reinforcement of the local anchorage zone has been defined according to EAD 160004-00-0301.

The test specimens are concrete prisms tested in axial compression with a concrete cross section $A_c = a \cdot b$:

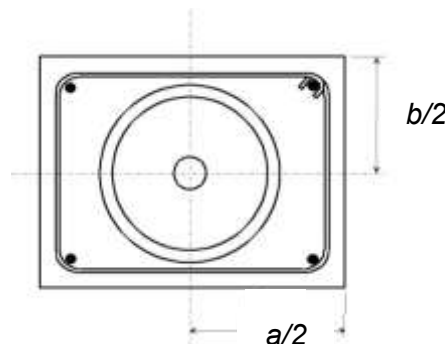

$a/2$ and $b/2$ are the distances between the anchorage axis and the edge of the test specimen.

VSL Post-Tensioning System

These reference dimensions a and b allow to obtain the minimum anchorage centre spacing in the structure in the x- and y- directions (x and y), such that:

$$A_c = x \cdot y \geq a \cdot b$$

The actual **spacing/centre distance** shall comply with:

$$\begin{aligned} x &\geq 0.85 a \\ y &\geq 0.85 b \end{aligned}$$

Where a, b: side lengths of test specimen
x, y: minimum specified centre spacing of the particular tendon in the structure, whichever is smaller; $x \leq y$

In the usual case of square or circular bearing plates the centre distance in both directions is equal ($a = b = X$) and the cross-section of the test specimen is X^2 .

The values of X and the minimum dimensions of concrete sections are given in the relevant tables of [Clause A.6](#) for the different types of anchorages and concrete strengths ([Type E](#), [Type CS](#), [Type GC](#), [Type NC/NC-U](#), [Type H](#)).

As explained above, it is possible to reduce the value of x in one of the directions (up to 0.85 X) if the product $x \cdot y \geq X^2$. This adaptation shall comply with the applicable design rules (see [Clause A.3.6 - Local anchorage zone reinforcement](#) for more details).

Edge distances in the structure are calculated with centre spacing in x- and y-direction by:

$$\begin{aligned} e_x &= \frac{x}{2} - 10 \text{ mm} + c \\ e_y &= \frac{y}{2} - 10 \text{ mm} + c \end{aligned}$$

Where e_x, e_y : Edge distance in x- in y-direction respectively
c: Concrete cover of reinforcement in the structure as required in the place of use

Note: 10 mm is the concrete cover of the test specimens (except for H anchorage block, where the concrete cover is 25 mm).

The local zones of adjacent anchorages should not overlap. In addition, they should remain inside the concrete.

The following table gives an overview of the different anchorages and minimum concrete strengths at time of stressing (cylinder/cube strength) for which anchorage spacing and local anchorage zone reinforcement are detailed in the data sheets ([Type E](#), [Type CS](#), [Type GC](#), [Type NC/NC-U](#), [Type H](#)).

VSL Post-Tensioning System

Type	$f_{c,min}(t)$ [N/mm ²] at time of stressing (cylinder/cube)				
E	23/28	28/35	32/40	36/45	43/53
CS		28/35			
GC	25/30	28/35	32/40	36/45	40/50
NC / NC-U					53/64
H		28/35			

$f_{c,min}(t)$ is the minimum concrete strength required at the time of stressing to the maximum possible stressing force P_{max} (see [Clause A.1.2 – Characteristics of system units](#) for more details). On site, the mean strength of concrete prisms / cubes tested shall be equal or bigger than the specified $f_{c,min}(t)$ at the time of stressing.

It remains possible however to partially tension the tendon in accordance with EN 1992-1-1 (Clause 5.10.2.2, point 4):

“If prestress in an individual tendon is applied in steps, the required concrete strength may be reduced. The minimum strength $f_{cm}(t)$ at the time t should be k_4 [%] of the required concrete strength for full prestressing given in the European Technical Approval. Between the minimum strength and the required concrete strength for full prestressing, the prestress may be interpolated between k_5 [%] and 100 % of the full prestressing.

Note: The values of k_4 and k_5 for use in a country may be found in its National Annex. The recommended value for k_4 is 50 and for k_5 is 30.”

For example, in the case of stressing to 50 % of the maximum value at the anchorage for example, the characteristic strength f_{cm0} may be reduced to approximately 2/3 of the value indicated above.

For particular applications (e.g. when using materials other than concrete), the project designer shall follow the applicable design rules (for instance Eurocodes with $P_{design} \geq 1.1 F_{pk}$ to design anchorage and deviation zones). Please contact VSL for more information.

A.3.6 Local anchorage zone reinforcement

As mentioned previously, a local anchorage zone reinforcement must be used as specified in [Clause A.6 - Schematic drawings](#). In accordance with EAD 160004-00-0301 this assumes the presence of additional general reinforcement of 50 kg/m³ in the structure.

For the E, CS, GC, NC, NC-U and H anchorages, the local zone reinforcement consists of spirals or orthogonal reinforcement (stirrups) or a combination of both solutions. The spiral reinforcement defined on the drawings in [Clause A.6](#) for these anchorages ([Type E](#), [Type CS](#), [Type GC](#), [Type NC/NC-U](#), [Type H](#)) displays a large enough pitch to allow for adequate concreting of the zone.

The local reinforcement of the anchorage zone is equal for the E and the EP anchor heads.

The local zone reinforcement specified in this ETA and confirmed in the load transfer tests, may be modified for a specific project if required. In that case, it shall comply with national design codes and be approved by the local authority and VSL to provide equivalent performance.

A.4 Stressing

A.4.1 Stressing equipment

The VSL equipment used for cable stressing is composed of stressing jacks, hydraulic pumps and measurement instruments.

A.4.1.1 Stressing jacks

The drawing in Clause A.6 (see [Clause A.6.9 – Block-out dimensions – Clearance requirements](#)) lists the VSL multistrand jacks and indicates the necessary clearances for installation. Multistrand jacks shall be used to stress all tendons. Stressing strand by strand is possible however on tendons without any deviation. Other models of jacks could be used if they are approved by VSL.

A.4.1.2 Hydraulic pumps

The jacks are connected to the VSL hydraulic pumps that have been designed for normal stressing speeds and contain the necessary safety elements.

A.4.1.3 Measurement instruments

Force and elongation are controlled with precision during the stressing operation by the measurement instruments.

A.4.2 Stressing procedure

Before stressing, the following must be checked:

- The safety rules and recommendations are known and are applied.
- The target values of force and elongations are correctly defined. The PT supervisor shall know the tolerances and shall take into account the necessary adjustments to these values.
- The PT supervisor knows the procedure to be adopted in case the values are outside of the tolerance (or for any other unanticipated incident).
- The sequence of stressing is correctly specified.
- The stressing equipment (including measurement instruments) complies with the guidelines of this ETA;
- The structure is able to support the post-tensioning loads and the concrete has achieved the required minimum strength in the local zone.
- The overlengths of the strands for stressing are in good conditions.

It is forbidden to remain behind the jack or within its immediate vicinity during stressing. The same precautions must be taken for the area at the back of a dead-end exposed anchor head.

One of the key characteristics of the VSL anchorages is its wedge-locking system. The wedges remain in constant contact with the strands during stressing and the load is automatically transferred from the jack to the anchor head when the pressure is released in the jack.

A.4.2.1 Force measurement

The jacking force (or the pressure in the jack) is usually the target value, since it can be measured directly and is directly proportional to the force along the cable in the structure. The pressure in the jack chamber is indicated by the manometers that are regularly recalibrated and are usually Class 1 (accuracy 1 % on the whole range). For the usual maximum pressure of 600 bar, the maximum admissible deviation is 6 bar.

In order to calculate the stressing force applied to the structure (and specified by the design engineer), the manometric force (obtained by multiplying the pressure reading by the pressure area) has to be corrected with the losses inside the jack and the losses due to friction of the strands in the anchorage.

The values of the losses inside the jacks are measured during their calibrations and vary from 1 % to 3 %.

The losses k_a in the active anchorages have the following values:

- E, CS, NC, NC-U or K 1-3 %.
- GC 2-3 %.

A.4.2.2 Elongation measurements

The cable elongation provides information on cable behaviour during stressing and gives an indication whether the targeted force diagram along the cable in the structure has been achieved.

The values of elongations are measured directly on the strands or the stressing jack. They are recorded for the different stressing stages on the stressing record data sheets.

The values are compared to the theoretical elongation values, which are calculated as indicated in [Clause A.2.6.2 - Basis for evaluating elongations](#).

A.5 Injection and sealing

A.5.1 General information

Post tensioning cables are prevented from corroding by the provision of a leak tight encapsulation for protection against external attack scenarios (e.g. migration of water, oxygen, chlorides from the structure's surface to the strands through excessive structural cracks) and a filler, which is used to fill the interstices between the strands in the duct and the anchorages. Depending on exposure conditions and environmental aggressivity of the structure protection level 1, 2 or 3 are specified in line with *fib Bulletin 33* to ensure adequate leak tight encapsulation on a specific project.

With regard to the filler the type of injection products is defined by the project. The products cannot be a threat to the hygiene, health and the environment.

A.5.2 Injection products (fillers)

The products used for the permanent protection of post-tensioning strands and anchorages may be categorized as follows:

A.5.2.1 Products for bonded cables and external cables (cementitious filler)

When the strands have to be bonded to the structure or for the corrosion and mechanical protection of external tendons, a product with a hydraulic cement base is used as filler. These products, which make use of performance enhancing admixtures to achieve both minimum sedimentation & and segregation but have still sufficient followability to fill the cables, have to be a cement grout complying with EN 447 or more stringent requirements if prescribed by the project. In some regions of the EU, unfavourable climatic conditions or other conditions impose the application of special grouts according to EAD 160027-00-0301.

In order to be able to completely fill a cable with a cementitious filler it is mandatory to seal all exposed anchor heads with either a temporary or permanent grout cap .

Concreting the block-out is only strictly necessary when using a temporary grouting cap (whether recycled or not). Should the permanent grouting cap be left apparent, the metallic parts must be protected against corrosion (see [Clause A.3.1.1 – Live end / dead end anchorages](#)).

A.5.2.2 Products for unbonded cables (flexible filler)

When the strands shall not be bonded to the duct and the structure (for instance, when the tendon has to remain replaceable or restressable), flexible filler products in accordance with EAD 160027-00-0301, such as the following, may be used:

- Grease based
- Wax based

Tendons with flexible filler needs to be encapsulated and the anchorages must be covered with a permanent waterproof protection cap. Concreting the block-out is not strictly necessary here (see above and [Clause A.3.1.1 – Live end / dead end anchorages](#)).

Products for bonded or unbonded injection covered by a European Technical Assessment may also be used in accordance with their categories of use.

Polymer based fillers (such as the flexible epoxy-urethane based Resipoly) are used to inject the E-WTe anchorages. Polymer based fillers are not assessed in this ETA.

A.5.3 Injection equipment

The injection equipment is adapted to the products to be injected.

For the cement-based grouts, the VSL injection equipment is composed for the most part of mixers and pumps integrated into a single device that enables preparing the grout and performing the injection. This equipment makes it possible to dose the grout components precisely and to obtain a perfectly-homogeneous mix. The pump is designed for continuous injection with an adequate debit.

For all cases, use of either temporary or permanent grout caps equipped with venting ports to seal the anchorages until the grout hardens is mandatory. For some applications (no venting port at tendon profile's high points, no distinctive high point etc), vacuum pumps are adopted to depressurise the ducts and achieve complete filling of the cables.

For injecting cables having bare strands with grease or petroleum wax after stressing, the VSL injection equipment is composed of melting devices or heaters, stirrers and pumps. Depending on the application, these components are either integrated or separated in various parts. Special safety precaution are needed to safe guard operators against potential spilling of the heated up grease or wax.

A.5.4 Injection and control procedure

Before grouting, the following must be checked:

- The injection product must comply with the requirements of this ETA and of EAD 160027-00-0301.
- The suitability of the proposed product for the specific project has been verified by 'Suitability testing' using the equipment as allocated for the project and the product constituents from the same source as supplied for the project.
- The full cable (free length and anchorages) is grout leak tight.
- The temperature of the air and of the structure are in accordance with the conditions of use of the injection product.
- Enough transparent tubes are available for conducting the daily wick induced test.

The leak tightness of the cable has to be verified prior to start with the injection. It is either checked by air pressure testing or by vacuum testing. Use of water to clear the cables from debris and/or checking the leak tightness with water is prohibited.

During the injection the PT crew must check at all outlets, intermediates vents and cap vents that the cable has been completely injected with the grout having the specified properties. This is basically achieved by confirming through measurement that the grout which flows out at these points has the same density as the grout mix's target density. Ports and vents shall only be closed once it has been confirmed by measurement, that grout which flows out has the required minimum density. Grouting procedures and grouting surveillance shall be carried out according to EN 446.

The quantity of injection product per unit cable length will be calculated as follows:

$$\text{Vol} = [(\text{internal duct section area} - \text{tendon section area}) \times (\text{unit length})] \times (1 + \xi)$$

Where ξ ($0.10 \leq \xi \leq 0.20$) accounts for losses and shape of the duct.

The relevant parameters associated with cable injection shall be recorded on the injection reports.

A.5.5 Sealing

The continuity of protection shall be ensured for the free length of the cable and for the anchorages. Refer to the [Clause A.3.1.1 – Live end / dead end anchorages](#) and the drawings in Clause A.6.

After removal of temporary caps, the block-out shall be patched with mortar. It may be necessary to complement this measure by a waterproof lining to prevent water penetration into the anchorage. Preferably, temporary caps may be replaced by permanent caps encapsulating the anchorage.

The permanent metallic caps (if protected by means of galvanization, paint, etc.) or polymeric caps may be left exposed.

Special attention needs to be given to the continuity of protection for internal cables crossing match cast segmental joints. Unless segmental couplers are used, which give a leak tight duct continuity over the joints, it is generally necessary to protect the strands in the joints by application of a water proofing membrane on all critically exposed concrete surfaces.

A.6 Schematic drawings

Figure 1 Wedge W6N Wedge W6S	42
Figure 2 Compression fitting CFE6	42
Figure 3 Insert CF6 Insert CF6N	42
Figure 4 Assembly 43	
Figure 5 Hole detail anchor head type E	44
Figure 6 Hole spacing anchor head type E	44
Figure 7 Cross section anchor heads type E and EP	44
Figure 8 Hole detail anchor head type CS	45
Figure 9 Hole spacing anchor head type CS	45
Figure 10 Cross section anchor head type CS	45
Figure 11 Permanent steel caps for anchorage type GC, E, NC, NC-U	46
Figure 12 Permanent polymeric caps for anchorage type CS	46
Figure 13 Categories of use and arrangements of anchorages type E	47
Figure 14 Anchorages type E-WTe (External unbonded tendons)- Arrangement without shim plate	48
Figure 15 Anchorages type E-WTe (External unbonded tendons)- Arrangement with shim plate	48
Figure 16 Deviator E-WTe – Flat deviator	49
Figure 17 Deviator E-WTe- Curved deviator	49
Figure 18 XT-deviator based on XT-pads	50
Figure 19 XT-deviator – Arrangement at the exit of guide tube	51
Figure 20 XT-deviator – Arrangement at mid length of the tendon	52
Figure 21 XT-deviator – Arrangement inside guide tube	53
Figure 22 Anchorages type E @ 23/28 and 28/35 MPa dimensions	54
Figure 23 Anchorages type E @ 32/40 and 36/45 MPa dimensions	55
Figure 24 Anchorages type E @ 43/53 MPa dimensions	56
Figure 25 Anchorage type E-WTe - Arrangement without shim plate - Dimensions	57
Figure 26 Anchorage type E-WTe - Arrangement with shim plate - Dimensions	58
Figure 27 Deviator E-WTe – Flat deviator - Geometry and dimensions	59
Figure 28 Deviator E-WTe – Curved deviator - Geometry and dimensions	60
Figure 29 Local anchorage zone reinforcement type E @ 23/28 MPa	61
Figure 30 Local anchorage zone reinforcement type E @ 28/35 MPa	62
Figure 31 Local anchorage zone reinforcement type E @ 32/40 MPa	63
Figure 32 Local anchorage zone reinforcement type E @ 36/45 MPa	64
Figure 33 Local anchorage zone reinforcement type E @ 43/53 MPa	65
Figure 34 Arrangements anchorage type CS cast in concrete structure	66
Figure 35 Arrangements anchorage type CS external tendon	67
Figure 36 Anchorages type CS @28/35 MPa dimensions	68
Figure 37 Local anchorage zone reinforcement type CS @ 28/35 MPa	69
Figure 38 Categories of use and arrangements anchorage type GC	70
Figure 39 Anchorages type GC standard bonded post-tensioning dimensions	71
Figure 40 Anchorages type GC external tendons dimensions	72
Figure 41 Anchorages type GC electrically isolated tendons dimensions	73
Figure 42 Local anchorage zone reinforcement type GC internal bonded post-tensioning	74
Figure 43 Local anchorage zone reinforcement type GC external and electrically isolated tendons	77
Figure 44 Categories of use arrangements anchorage type NC and NC-U	81
Figure 45 Assembly with threaded anchor head for load monitoring	82
Figure 46 Anchorages type NC and NC-U @53/64 MPa dimensions	83
Figure 47 Local anchorage zone reinforcement type NC and NC-U @ 53/64 MPa	84
Figure 48 Anchorage and local anchorage reinforcement type H @ 28/35 MPa	85
Figure 49 Categories of use arrangements couplers type K	87
Figure 50 Couplers type K dimensions	88
Figure 51 Category of use arrangement couplers type V	89
Figure 52 Couplers type V dimensions	89
Figure 53 Block-out dimensions – Clearance requirements	90
Figure 54 Dimensions and types of XT-pads	91
Figure 55 Serial arrangement of VSL XT-Pad as saddle deviator	92
Figure 56 Ducting dimensions	93
Figure 57 Segmental Couplers – PT-Plus Round Duct	93

A.6.1 STANDARD ANCHORAGE PARTS

A.6.1.1 WEDGES

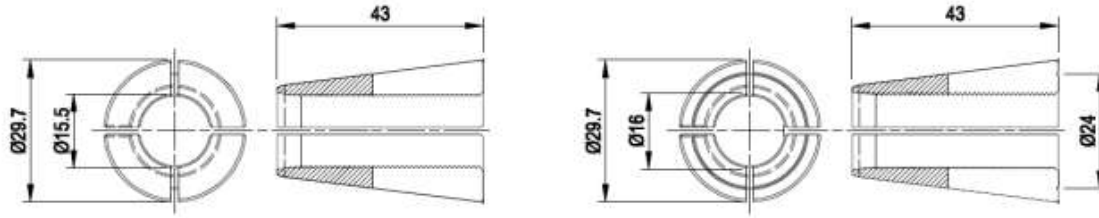
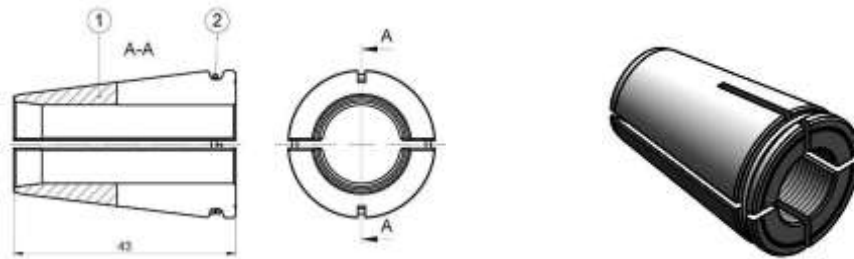

Figure 1 Wedge W6N

Wedge W6S

NB: Wedges W6N and W6S can be fabricated with or without clip.



A.6.1.2 COMPRESSION FITTINGS

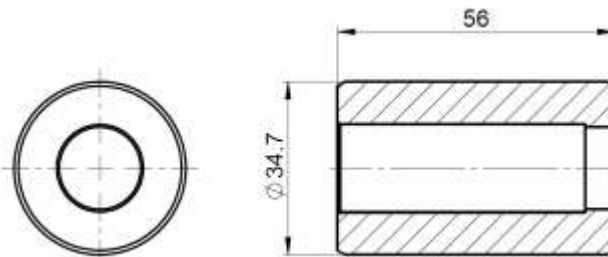

Figure 2 Compression fitting CFE6

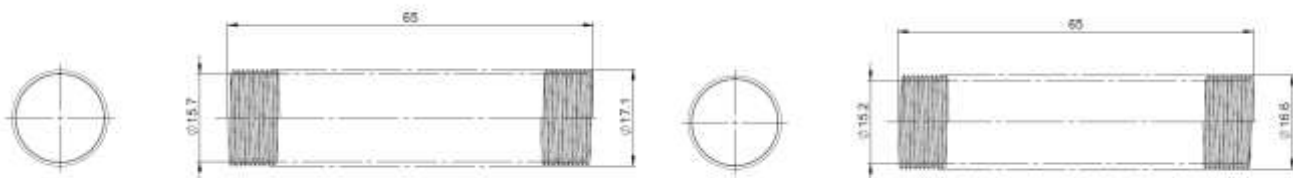

Figure 3 Insert CF6

Insert CF6N

VSL Post-Tensioning System

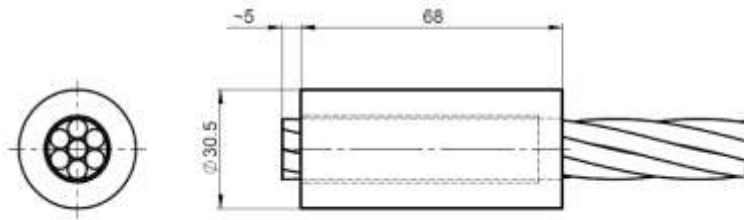

Figure 4 Assembly

A.6.1.3 ANCHOR HEADS TYPE E AND EP

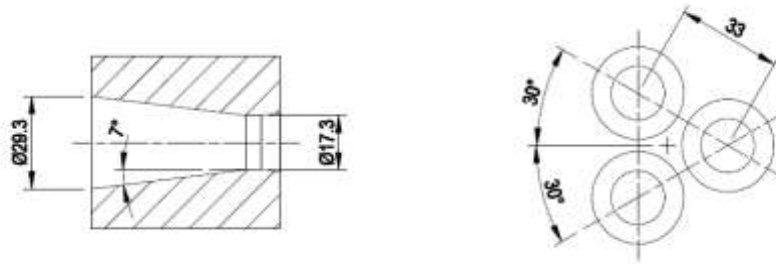

Figure 5 Hole detail anchor head type E

Note: the EP anchor heads feature a cylindrical drilling

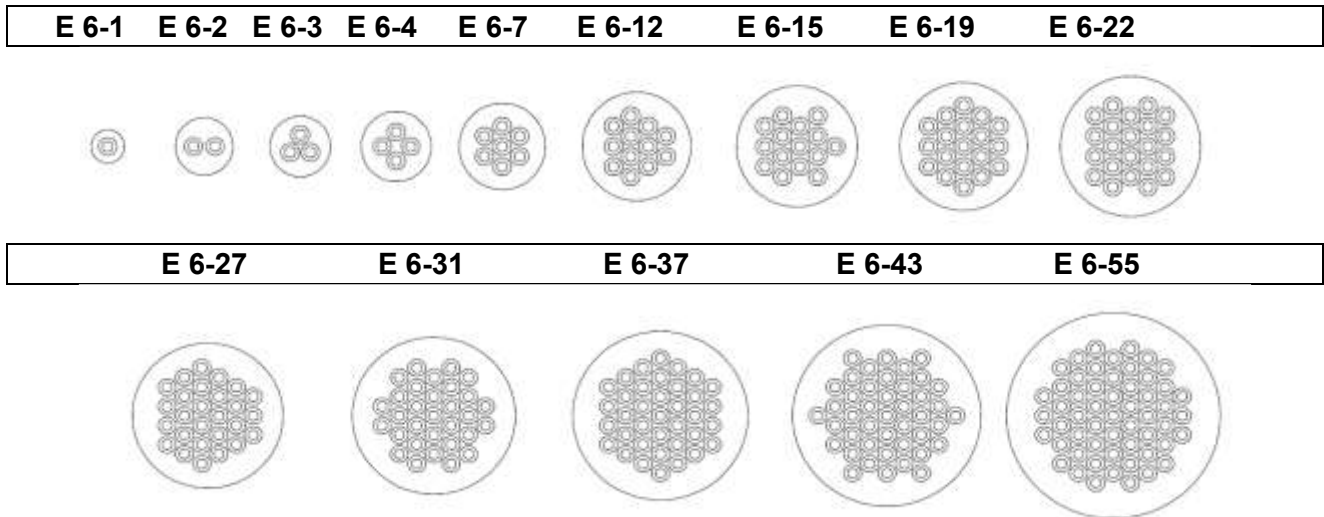

Figure 6 Hole spacing anchor head type E

Note: the hole distribution is identical for anchor heads type EP

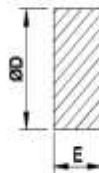
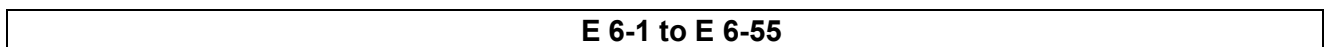

Figure 7 Cross section anchor heads type E and EP

For dimensions ØD and E see the relevant tables of dimensions for anchorages type E, GC, NC and NC-U

A.6.1.4 ANCHOR HEADS TYPE CS

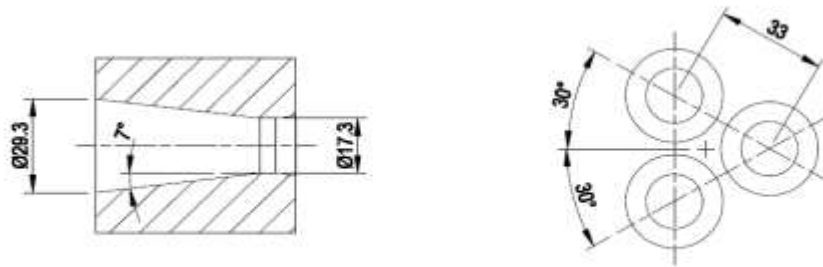

Figure 8 Hole detail anchor head type CS

6-7	6-12	6-19	6-22	6-27	6-31	6-37
STANDARD, PLUS, SUPER & EXTERNAL						

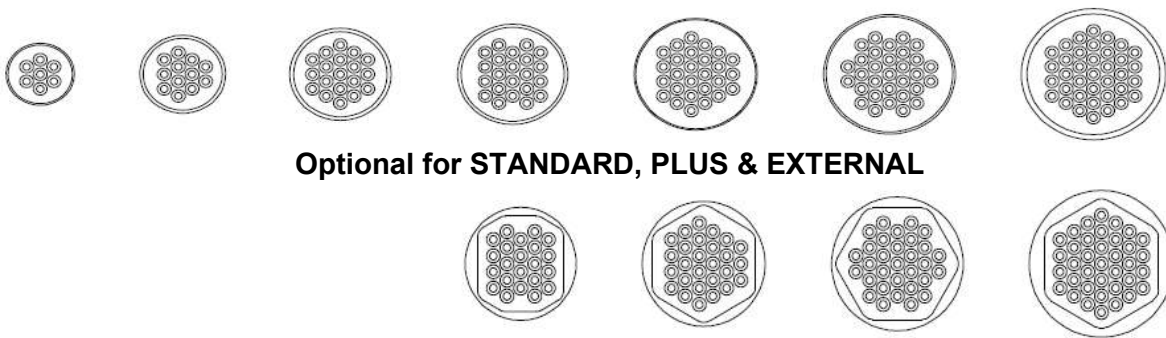

Figure 9 Hole spacing anchor head type CS

6-7 to 6-37	
STANDARD, PLUS & EXTERNAL	SUPER



Figure 10 Cross section anchor head type CS

For sizes ØD and E see ANCHORAGES TYPE CS – SIZES

A.6.1.5 PROTECTIVE CAPS FOR ANCHORAGES

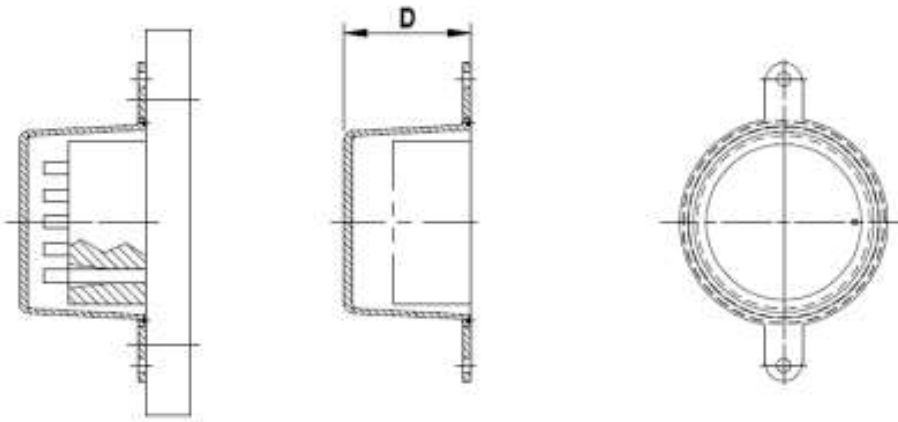

Figure 11 Permanent steel caps for anchorage type GC, E, NC, NC-U

Unit	D
6-3	106
6-4	111
6-7	118
6-12	134
6-15	145
6-19	155
6-22	162
6-27	173
6-31	183
6-37	200
6-43	210
6-55	225

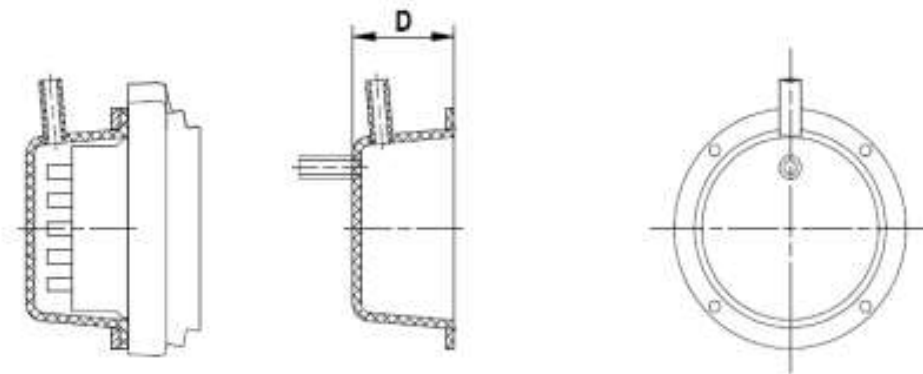

Figure 12 Permanent polymeric caps for anchorage type CS

Unit	D
6-7	112
6-12	113
6-19	114
6-22	115
6-27	140
6-31	150
6-37	160

A.6.2 ANCHORAGES TYPE E

A.6.2.1 CATEGORIES OF USE AND ARRANGEMENTS

Anchorage cast in concrete structure

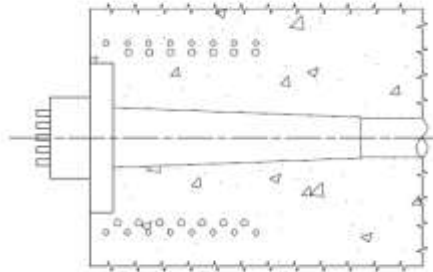

Anchorage placed against concrete structure

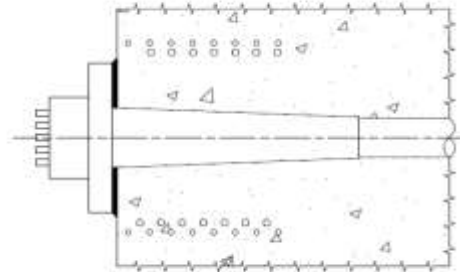

Anchorage inserted in masonry structure

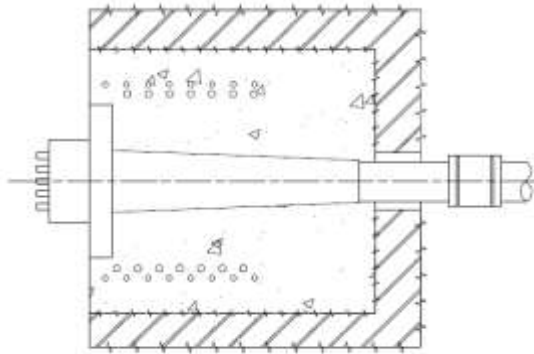

Anchorage placed against steel structure

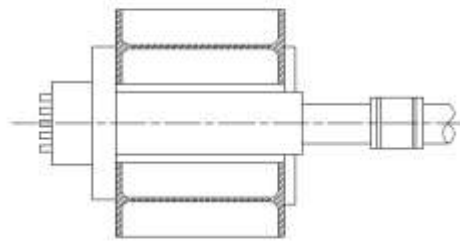

Anchorage placed against wood structure

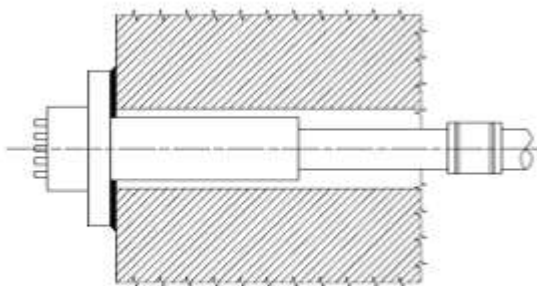

Anchorage with EP anchor head

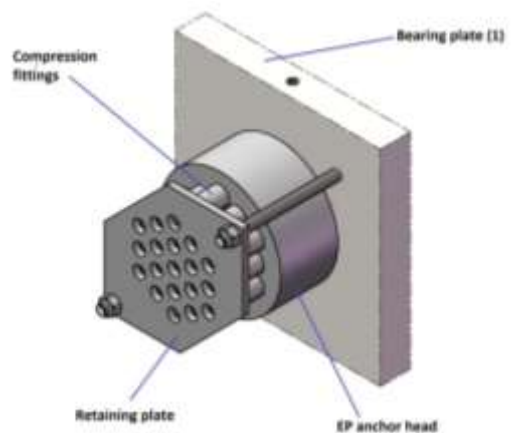
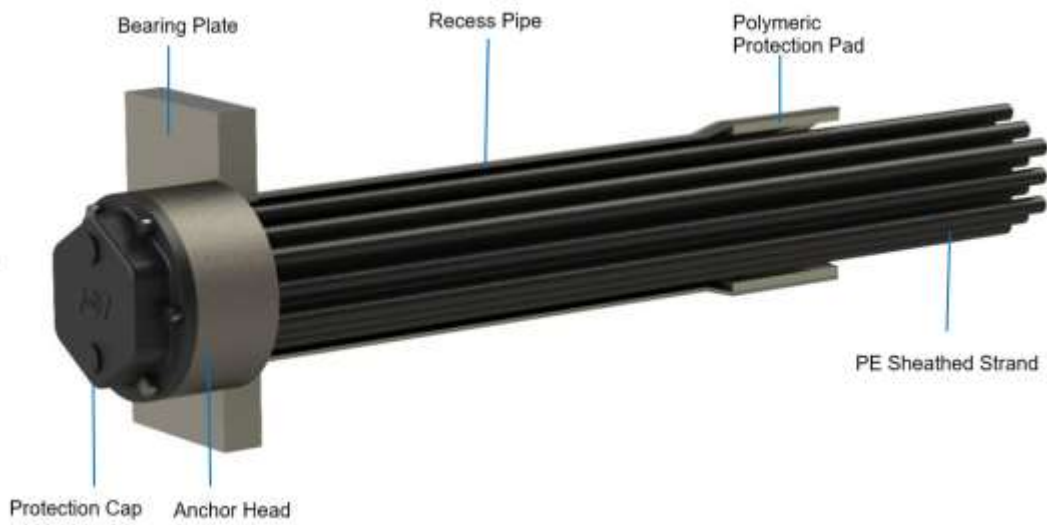

Figure 13 Categories of use and arrangements of anchorages type E

- (1) An E bearing plate is displayed. Assembly of EP anchor heads is also possible with GC, NC or NC-U plates.

VSL Post-Tensioning System



**Figure 14 Anchorages type E-WTe (External unbonded tendons)-
Arrangement without shim plate**

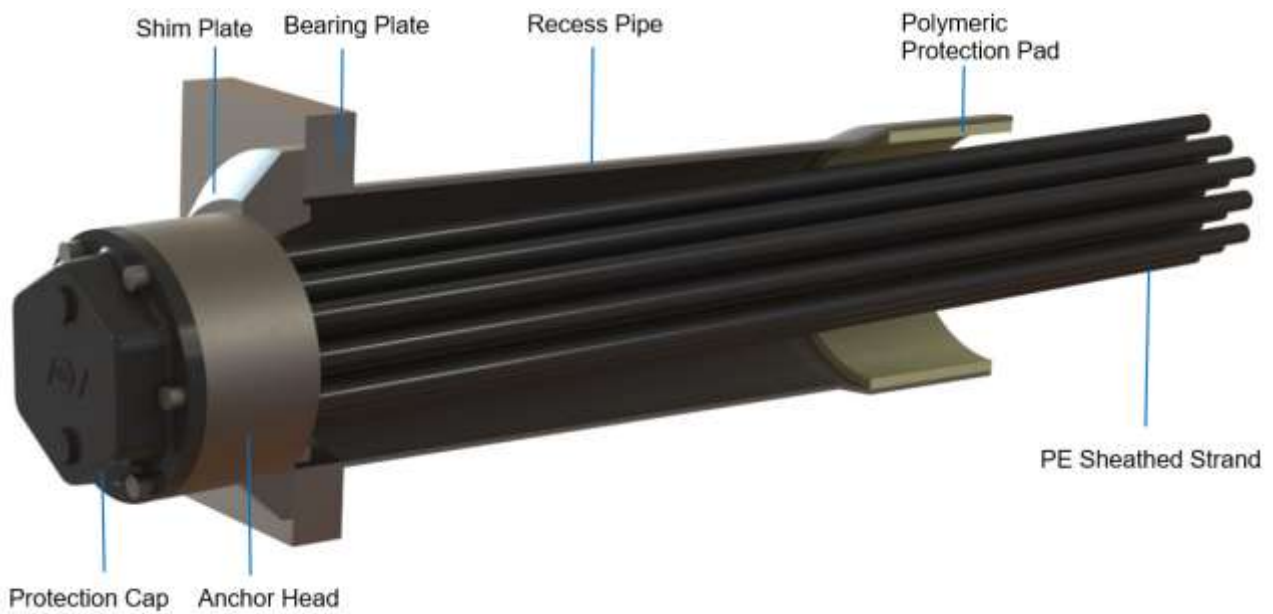

**Figure 15 Anchorages type E-WTe (External unbonded tendons)-
Arrangement with shim plate**

VSL Post-Tensioning System

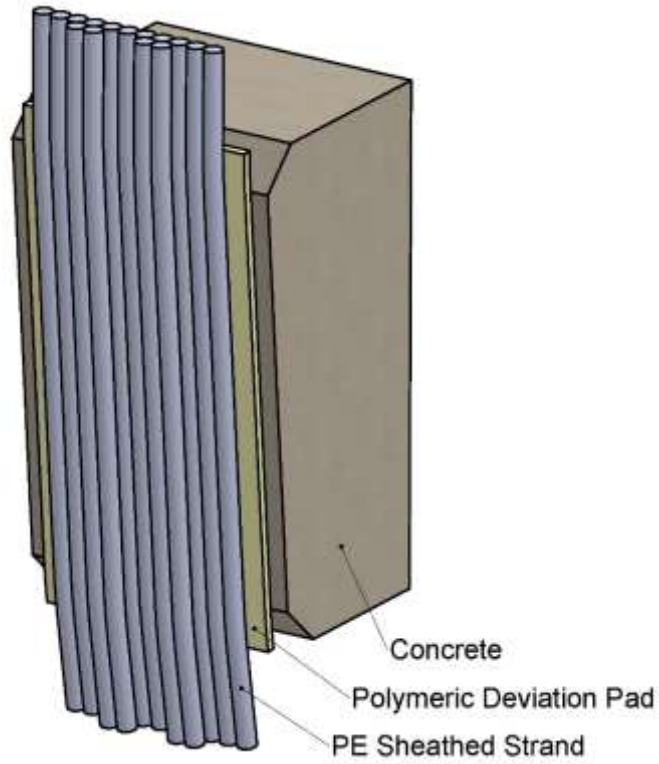

Figure 16 Deviator E-WTe – Flat deviator

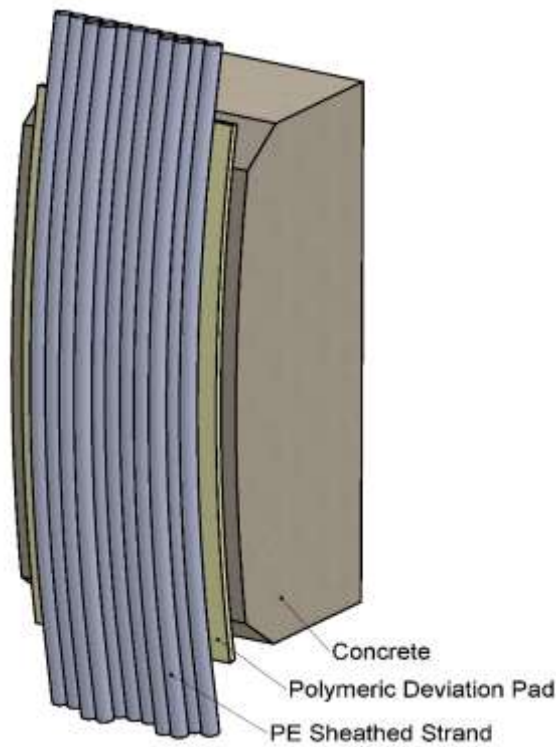

Figure 17 Deviator E-WTe- Curved deviator

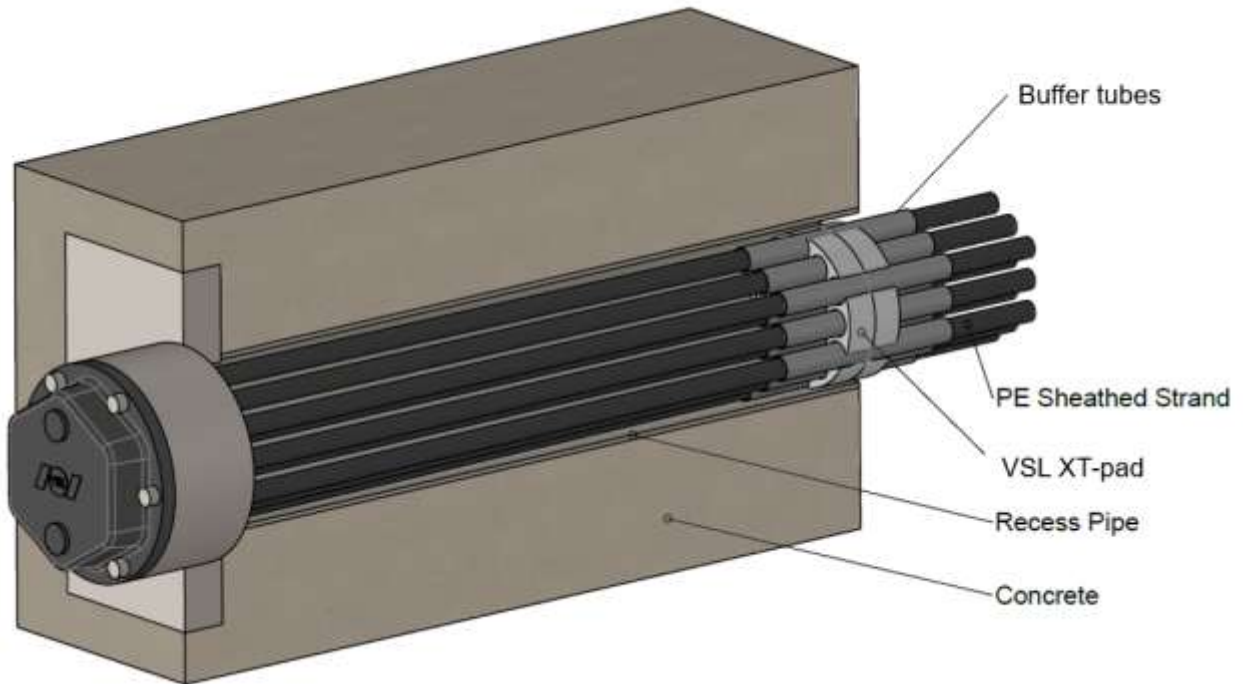

Figure 18 XT-deviator based on XT-pads

Notes: The above figure shows the principle of a XT-deviator including a metal core (VSL XT-pad) and polymeric buffer tubes, providing support to the individual sheathed and protected strands.
It includes a super-compact XT-pad and is inserted in a circular reservation. Other configurations with compact or parallel XT-pads are possible.

VSL Post-Tensioning System

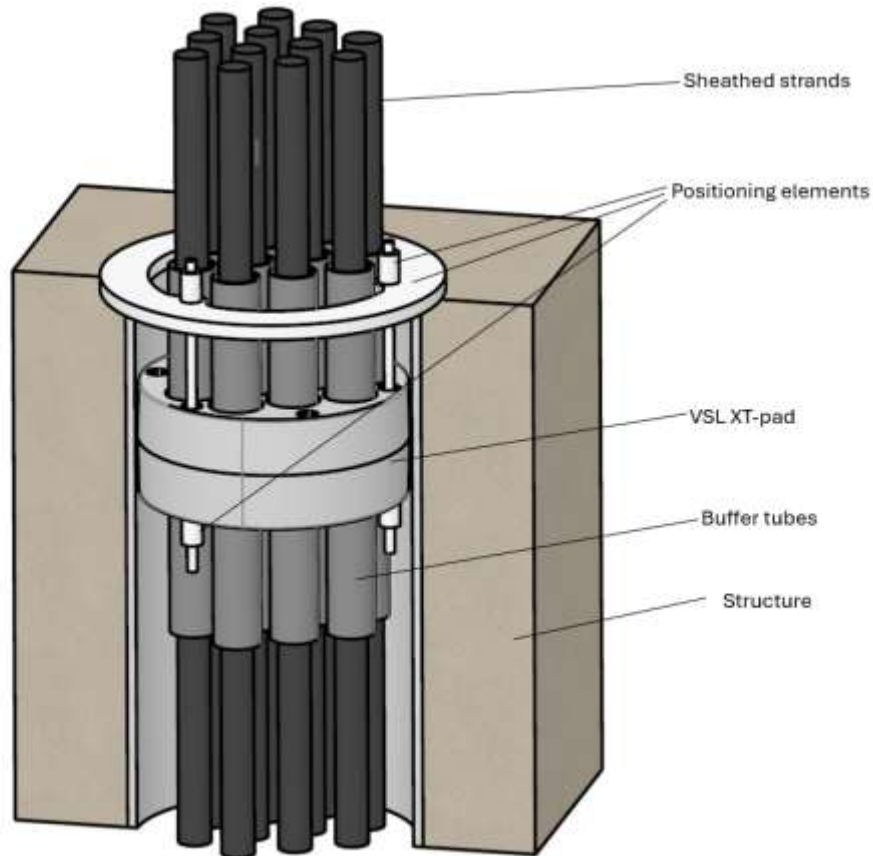

Figure 19 XT-deviator – Arrangement at the exit of guide tube

Notes: The above figure depicts an example of implementation of XT-deviator including a parallel XT-pad and polymeric buffer tubes. It is positioned at the exit of a bottom guide tube and includes a positioning system formed by a plate and threaded rod. Other configurations with compact or super-compact XT-pads are possible.

VSL Post-Tensioning System

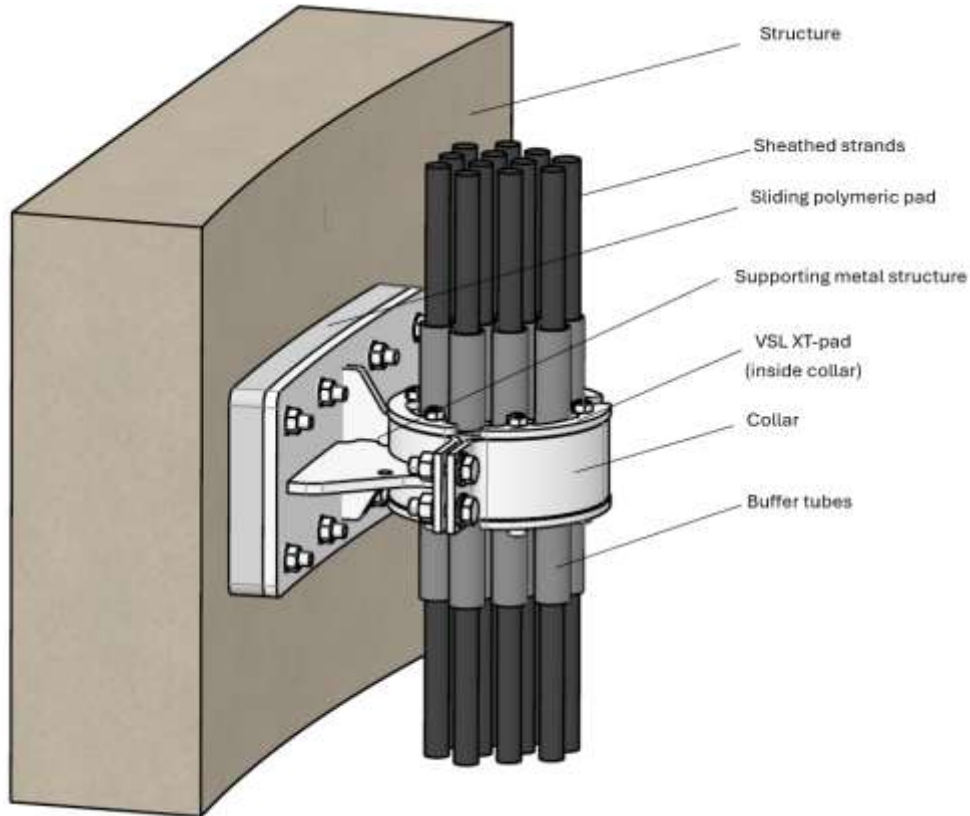

Figure 20 XT-deviator – Arrangement at mid length of the tendon

Notes: The above figure depicts an example of implementation of XT-deviator, typically found at mid height of vertical tendons inside wind towers. It includes a XT-pad, a set of polymeric buffer tubes, a supporting metal structure and a sliding polymeric pad as an interface with the outer concrete structure. The metallic support may be fixedly connected to the concrete structure (by bolts, connectors, welds, etc.), thus creating a fixity clamp. Other configurations (open support, closed collar, etc.) are also possible.

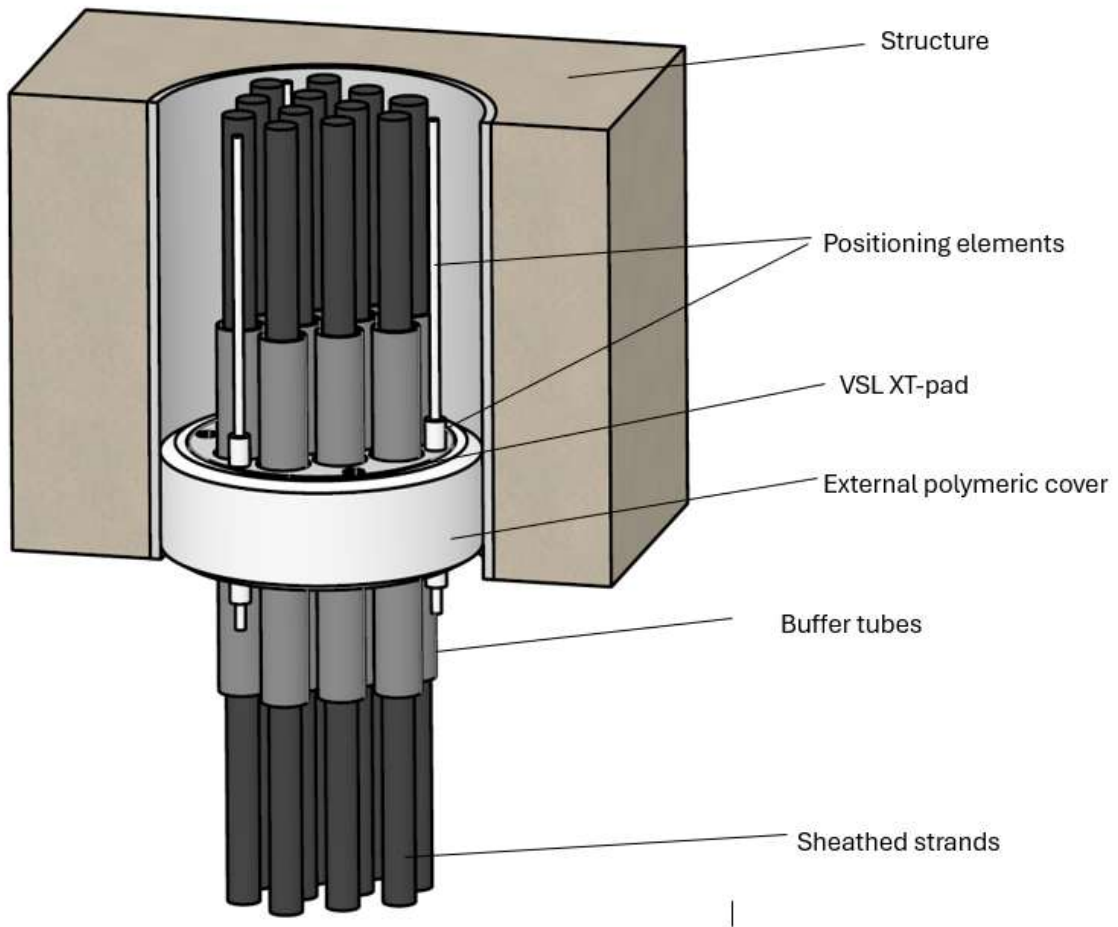

Figure 21 XT-deviator – Arrangement inside guide tube

Notes: The above figure depicts an example of implementation of XT-deviator, typically found inside the guide tube of the top anchorage of vertical tendons inside wind towers. It includes a XT-pad, polymeric buffer tubes, wires to support the deviator and an external polymeric ring as an interface with the outer concrete structure. Other configurations are also possible.

A.6.2.2 ANCHORAGES TYPE E @ 23/28 AND 28/35 MPa (Internal bonded tendons)

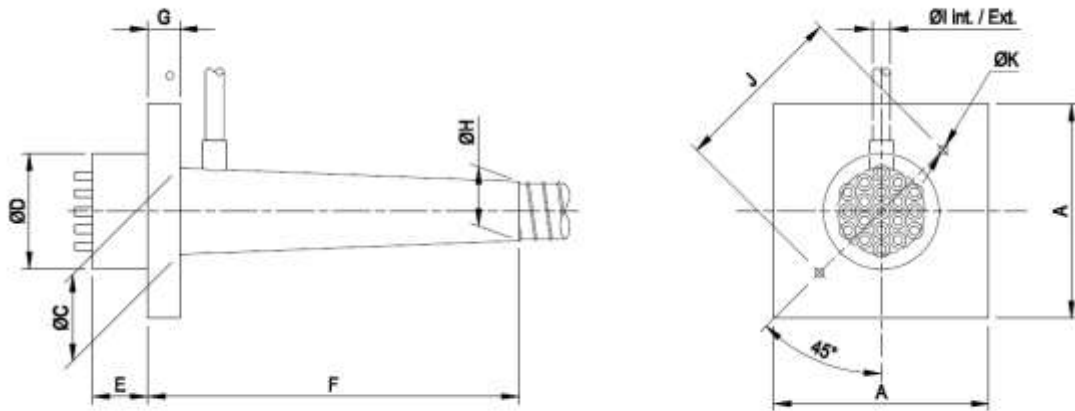

Figure 22 Anchorages type E @ 23/28 and 28/35 MPa dimensions

Dimensions for use with concrete with $f_{c,min(t)} \geq 23/28$ (and 28/35) N/mm² (cylinder/cube) at time of stressing

Unit	□A	ØC	Anchor heads E/EP		Anchor heads E(QT)/EP(QT)		F	G	ØH	ØI	J ⁽¹⁾	K
			ØD	E	ØD	E						
6-1	75	18	53	50	53	50	150	10	25	21/25	86	Ø5
6-2	110	50	90	50	86	50	200	10	50	21/25	136	Ø5
6-3	135	56	95	50	95	50	205	15	55	21/25	135	M12
6-4	160	65	110	55	106	50	210	20	60	21/25	150	M12
6-7	205	84	135	60	135	55	320	30	72	28/32	210	M12
6-12	270	118	170	75	166	62	500	40	92	28/32	265	M16
6-15	305	143	190	85	186	68	585	45	97	28/32	275	M16
6-19	340	150	200	95	196	73	640	50	107	28/32	280	M16
6-22	370	172	220	100	216	78	745	55	122	28/32	310	M16
6-27	410	185	240	110	236	85	690	60	132	28/32	330	M16
6-31	435	192	260	120	256	90	755	65	142	28/32	360	M16
6-37	480	215	280	135	276	98	905	75	155	28/32	370	M16
6-43	520	248	320	145	316	105	1030	80	165	28/32	420	M20
6-55	580	255	340	160	340	118	1045	95	185	28/32	452	M20

All dimensions in [mm]. Dimensions correspond to anchorages with bare strands. For dimensions with sheathed protected strands, check with VSL.

⁽¹⁾ J spacing of holes for fixation to formwork

A.6.2.3 ANCHORAGES TYPE E @ 36/45 AND 32/40 MPa (Internal bonded tendons)

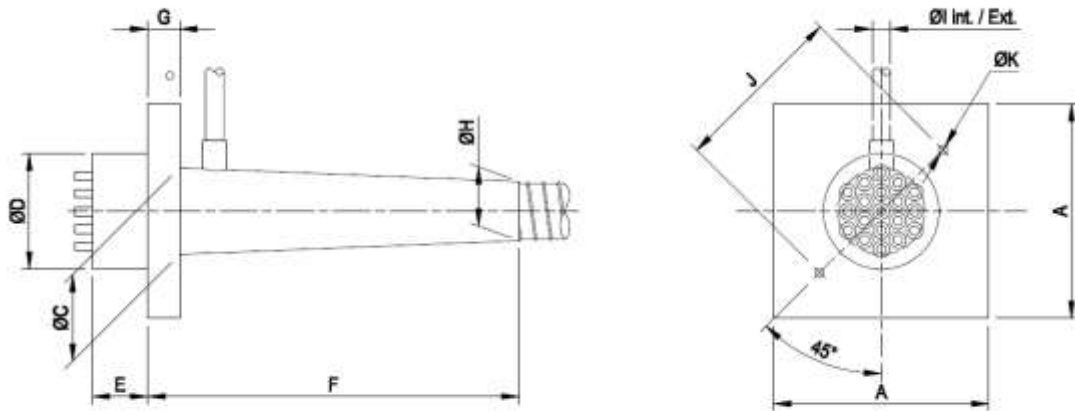

Figure 23 Anchorages type E @ 32/40 and 36/45 MPa dimensions

Dimensions for use with concrete with $f_{c,min(t)} \geq 32/40$ (and 36/45) N/mm² (cylinder/cube) at time of stressing

Unit	□A	ØC	Anchor heads E/EP		Anchor heads E(QT)/EP(QT)		F	G	ØH	ØI	J ⁽¹⁾	K
			ØD	E	ØD	E						
6-1	70	18	53	50	53	50	150	10	25	21/25	79	Ø5
6-2	100	50	90	50	86	50	200	10	50	21/25	122	Ø5
6-3	125	56	95	50	95	50	205	15	55	21/25	135	M12
6-4	145	65	110	55	106	50	210	20	60	21/25	150	M12
6-7	175	84	135	60	135	55	315	25	72	28/32	210	M12
6-12	230	118	170	75	166	62	495	35	92	28/32	265	M16
6-15	265	143	190	85	186	68	580	40	97	28/32	275	M16
6-19	290	150	200	95	196	73	635	45	107	28/32	280	M16
6-22	320	172	220	100	216	78	740	50	122	28/32	310	M16
6-27	350	185	240	110	236	85	685	55	132	28/32	330	M16
6-31	370	192	260	120	256	90	750	60	142	28/32	360	M16
6-37	410	215	280	135	276	98	900	70	155	28/32	370	M16
6-43	450	248	320	145	316	105	1025	75	165	28/32	420	M20
6-55	500	255	340	160	340	118	1040	90	185	28/32	452	M20

All dimensions in [mm]. Dimensions correspond to anchorages with bare strands. For dimensions with sheathed protected strands, check with VSL.

⁽¹⁾ J spacing of holes for fixation to formwork

A.6.2.4 ANCHORAGES TYPE E @ 43/53 MPa (Internal bonded tendons)

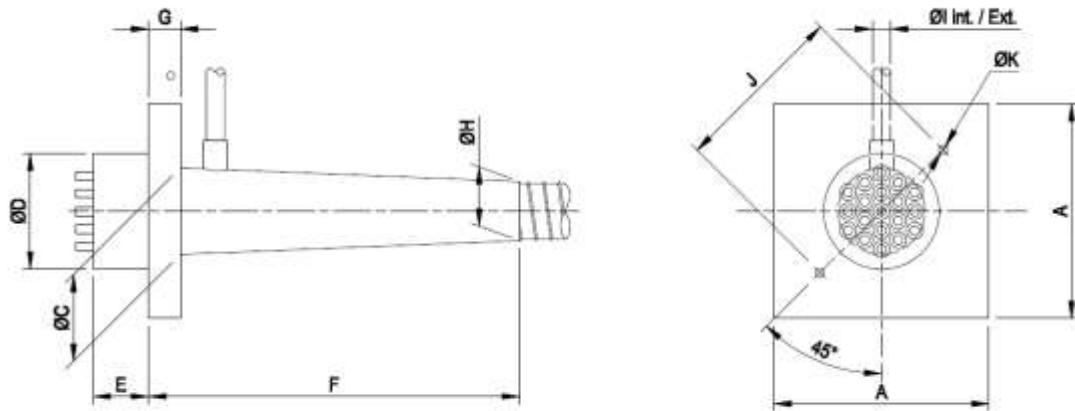

Figure 24 Anchorages type E @ 43/53 MPa dimensions

Dimensions for use with concrete with $f_{c,min(t)} \geq 43/53 \text{ N/mm}^2$ (cylinder/cube) at time of stressing

Unit	□A	ØC	Anchor heads E/EP		Anchor heads E(QT)/EP(QT)		F	G	ØH	ØI	J ⁽¹⁾	K
			ØD	E	ØD	E						
6-1	65	18	53	50	53	50	150	10	25	21/25	78	Ø5
6-2	95	50	90	50	86	50	200	10	50	21/25	115	Ø5
6-3	120	56	95	50	95	50	205	15	55	21/25	135	M12
6-4	130	65	110	55	106	50	210	20	60	21/25	150	M12
6-7	160	84	135	60	135	55	315	25	72	28/32	190	M12
6-12	210	118	170	75	166	62	495	35	92	28/32	240	M16
6-15	240	143	190	85	186	68	580	40	97	28/32	275	M16
6-19	270	150	200	95	196	73	635	45	107	28/32	280	M16
6-22	290	172	220	100	216	78	740	50	122	28/32	310	M16
6-27	320	185	240	110	236	85	685	55	132	28/32	330	M16
6-31	340	192	260	120	256	90	750	60	142	28/32	360	M16
6-37	375	215	280	135	276	98	895	65	155	28/32	370	M16
6-43	410	248	320	145	316	105	1020	70	165	28/32	420	M20
6-55	450	255	340	160	340	118	1030	80	185	28/32	452	M20

All dimensions in [mm]. Dimensions correspond to anchorages with bare strands. For dimensions with sheathed protected strands, check with VSL.

⁽¹⁾ J spacing of holes for fixation to formwork

A.6.2.5 ANCHORAGES TYPE E-WTe (External unbonded tendons)

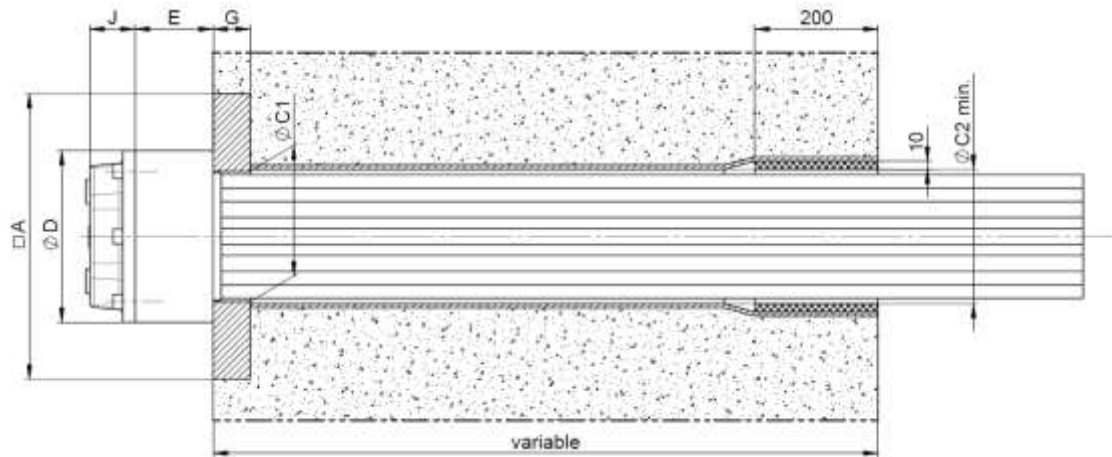

Figure 25 Anchorage type E-WTe - Arrangement without shim plate - Dimensions

Unit	□A ⁽¹⁾	ØC1	ØC2 _{min}	ØD	E ⁽²⁾	G ⁽¹⁾	J
6-4	140	74	77	116	105	20	50
6-7	170	93	96	148	105	25	50
6-12	220	127	130	185	105	35	50
6-15	250	152	155	195	105	40	50
6-19	280	162	165	210	105	45	50
6-22	300	181	184	240	105	50	60
6-27	330	194	197	255	115	55	70
6-31	350	205	208	276	125	60	70
6-37	385	224	227	296	140	65	75
6-43	420	257	260	336	150	70	80
6-55	460	264	267	356	165	80	80

All dimensions in [mm]

⁽¹⁾ A, G Dimensions of bearing plate for use with concrete with $f_{c,min(t)} \geq 43/53 \text{ N/mm}^2$ (cylinder/cube) at time of stressing. For other concrete grades, refer to relevant tables on previous chapters.

⁽²⁾ E Height indicated above correspond to anchor heads with non-QT material. For dimensions with QT material, contact VSL.

General Optional pipe on the free length not displayed.
Recess pipes may be fitted with soft deviator elements at their exit to prevent contact between steel and concrete during installation and in case of unintentional deviations up to 0.5° .

VSL Post-Tensioning System

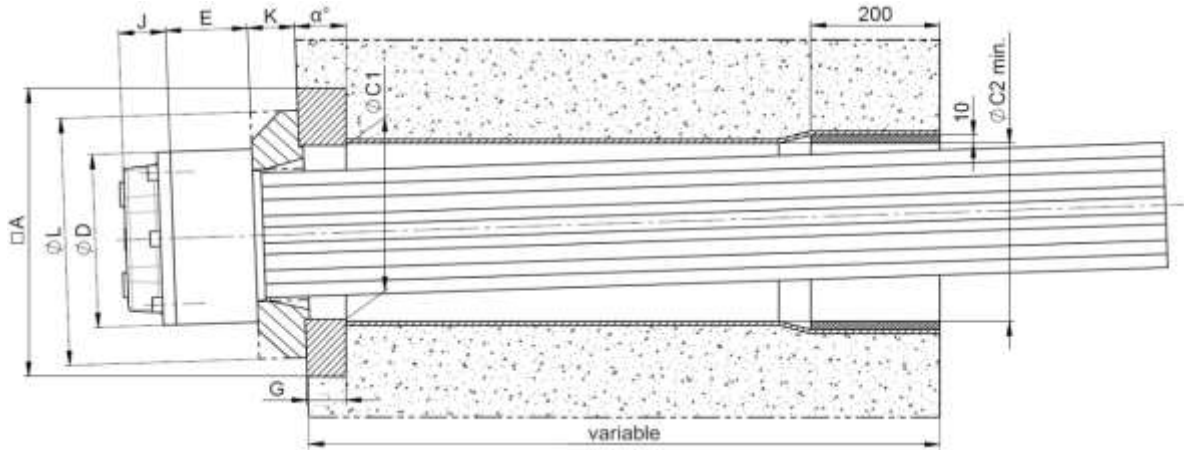

Figure 26 Anchorage type E-WTe - Arrangement with shim plate - Dimensions

Unit	$\square A$ ⁽¹⁾	$\varnothing C1$	$\varnothing C2_{min}$ ⁽²⁾	$\varnothing D$	E ⁽⁴⁾	G ⁽¹⁾	J	K_m ⁽³⁾	K_c ⁽³⁾	$\varnothing L$	α°
6-4	155	115	115	110	105	20	50	25	35	150	0-2°
6-7	190	140	140	135	105	25	50	30	45	180	0-2°
6-12	240	175	175	170	105	35	50	35	50	220	0.2°
6-15	270	195	195	190	105	40	50	40	55	250	0-2°
6-19	300	203	203	198	105	45	50	45	60	260	0.2°
6-22	320	228	228	220	105	50	60	45	70	285	0-2°
6-27	355	248	248	240	115	55	70	50	80	315	0.2°
6-31	380	268	268	260	125	60	70	55	85	340	0-2°
6-37	415	288	288	280	140	65	75	60	90	365	0.2°
6-43	455	328	328	320	150	70	80	60	100	410	0-2°
6-55	500	348	348	340	165	80	80	75	120	450	0-2°

All dimensions in [mm]

- (1) A, G Dimensions of bearing plate for use with concrete with $f_{c,min(t)} \geq 43/53 \text{ N/mm}^2$ (cylinder/cube) at time of stressing. For other concrete grades, refer to relevant tables on previous chapters.
- (2) $C2_{min}$ Inside diameter of tube might have to be increased depending on tendon installation method.
- (3) K Minimum thickness of shim plate. Depending on the project requirements the shim plate can be in two parts (split shim) or in one single piece (ring shim). Dimensions shown correspond to machined (K_m) and cast (K_c) shims.
- (4) E Height indicated above correspond to anchor heads with non-QT material. For dimensions with QT material, contact VSL.

General Optional pipe on the free length is not displayed on the drawing.

Recess pipes may be fitted with soft deviator elements at their exit to prevent contact between steel and concrete during installation and in case of unintentional deviations up to 0.5°.

The picture above depicts a tapered bearing plate (0° to 2°). Alternatively a tapered shim or a tapered washer may be adopted for deviations between 0.5° and 2° to restore perpendicularity of the tendon.

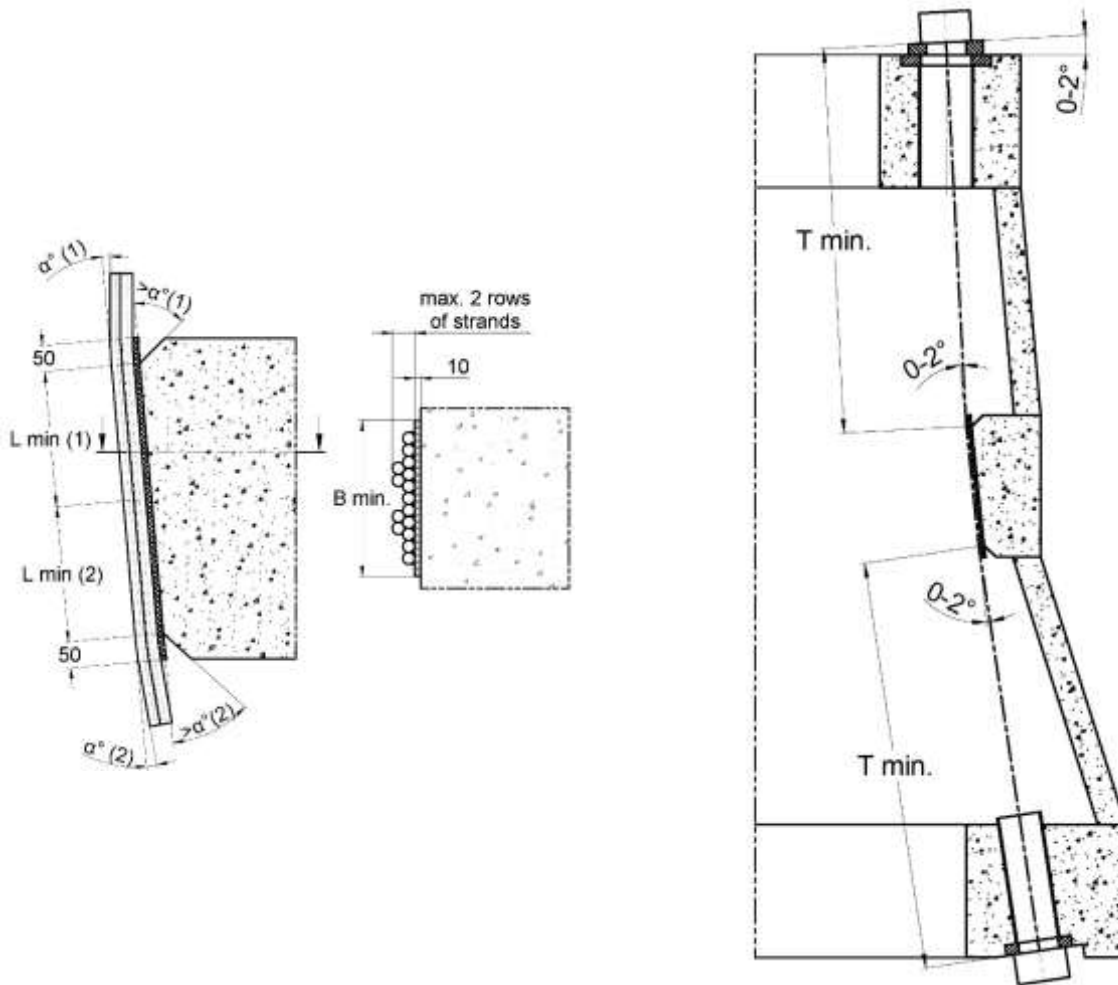

Figure 27 Deviator E-WTe – Flat deviator - Geometry and dimensions

α° (1)	L_{\min} (1)
0°	0
0.5°	90
1°	175
1.5°	265
2°	350

Unit	B_{\min}	T_{\min}
6-4	140	2400
6-7	200	3500
6-12	340	6400
6-15	400	8700
6-19	480	10500
6-22	540	13500
6-27	640	16000
6-31	720	20000

All dimensions in [mm]

Deviator support to be mounted perpendicular to the plane of deviation.

⁽¹⁾ α , L_{\min} Deviation angles $\alpha(1)$ and $\alpha(2)$ can be different, but each single deviation shall not exceed 2°. Total deviation of the tendon may go up to 2α with a length $2 L_{\min}$.

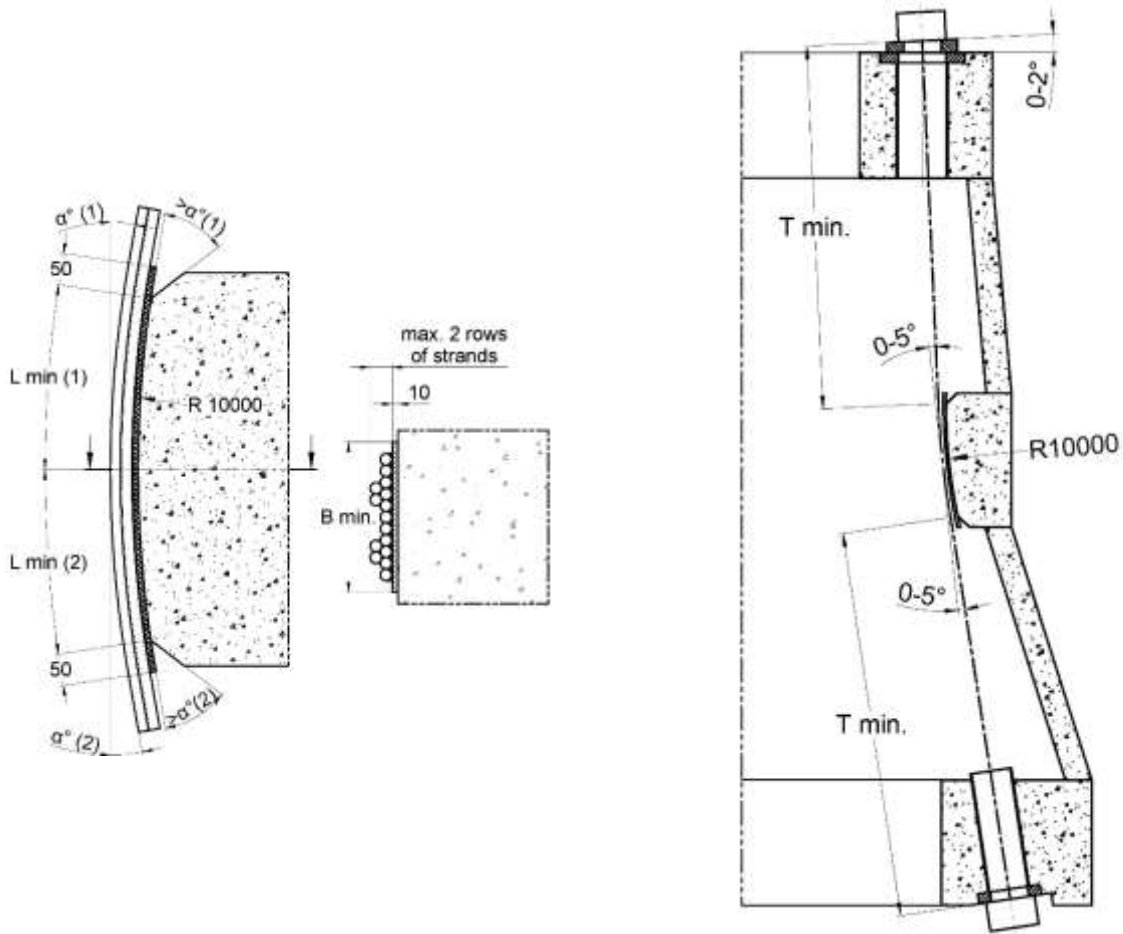

Figure 28 Deviator E-WTe – Curved deviator - Geometry and dimensions

α° ⁽¹⁾	L_{min} ⁽¹⁾
1°	175
2°	260
3°	525
4°	700
5°	875

Unit	B_{min}	T_{min}
6-4	140	2400
6-7	200	3500
6-12	340	6400
6-15	400	8700
6-19	480	10500
6-22	540	13500
6-27	640	16000
6-31	720	20000

All dimensions in [mm]

Deviator support to be installed perpendicular to the plane of deviation.

⁽¹⁾ α , L_{min} Deviation angles $\alpha(1)$ and $\alpha(2)$ can be different, but each single deviation shall not exceed 5°. Total deviation of the tendon may go up to 2α with a length $2 L_{min}$.

A.6.2.6 LOCAL ANCHORAGE ZONE REINFORCEMENT TYPE E @ 23/28 MPa

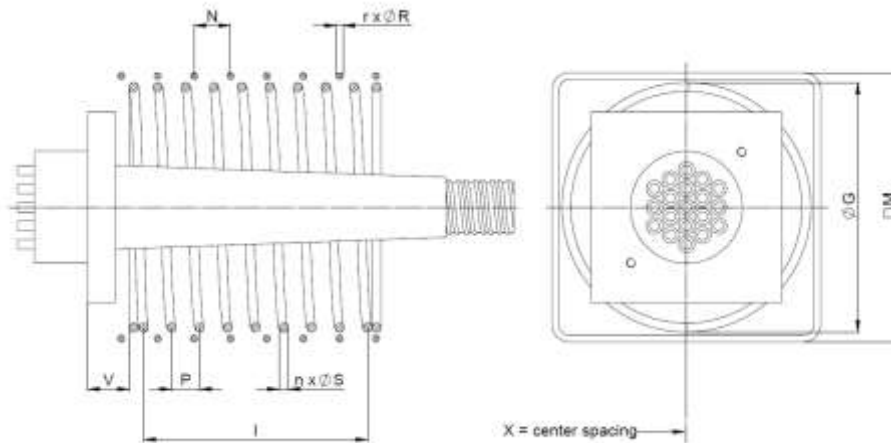

Figure 29 Local anchorage zone reinforcement type E @ 23/28 MPa

Reinforcement for concrete with $f_{c,min(t)} \geq 23/28 \text{ N/mm}^2$ (cylinder/cube) at time of stressing

Unit	COMBINATION SPIRAL + STIRRUPS									ALTERNATIVE SPIRAL ONLY					$V_{max}^{(3)}$	$X^{(4)}$
	SPIRAL REINF.					+ STIRRUPS										
	$\varnothing S$	$n^{(1)}$	P	$\varnothing G$	I	$\varnothing R$	$r^{(2)}$	N	M	$\varnothing S$	$n^{(1)}$	P	$\varnothing G$	I		
6-1	10	5	60	100	180	-	-	-	-	10	5	60	100	180	40	120
6-2	12	5	60	150	180	-	-	-	-	12	5	60	150	180	40	170
6-3	12	5	55	185	165	-	-	-	-	12	5	55	185	165	45	205
6-4	12	6	50	220	200	-	-	-	-	12	6	50	220	200	50	240
6-7	12	6	60	260	240	12	4	75	295	16	6	60	260	240	60	315
6-12	16	7	65	345	325	12	7	70	390	16	8	55	390	330	70	410
6-15	16	7	75	390	375	16	6	75	435	20	7	70	435	350	75	455
6-19	16	9	60	450	420	16	6	90	495	20	8	65	495	390	80	515
6-22	16	10	60	490	480	16	7	75	535	20	10	60	535	480	85	555
6-27	16	11	55	545	495	16	8	70	595	20	11	55	595	495	90	615
6-31	16	12	55	585	550	16	10	60	635	20	13	50	635	550	95	655
6-37	20	11	65	645	585	16	9	75	695	20	15	45	695	585	105	715
6-43	20	13	60	705	660	16	10	70	750	25	12	65	750	650	110	770
6-55	20	14	60	805	720	16	15	55	855	25	14	60	855	720	125	875

All dimensions in [mm]. Two possibilities are given for reinforcement: either a combination of spiral and stirrups (orthogonal reinforcement) or an alternative with spiral reinforcement only. Other combinations with equivalent performance (to be approved by VSL) are also possible.

Reinforcement steel $f_{yk} \geq 500 \text{ N/mm}^2$

(1) n Number of turns including first and last turn required for anchorage of spiral. First spiral turn (bearing plate) tied back to adjacent one.

(2) r Number of reinforcement layers

(3) $V_{max} \geq V \geq V_{min}$; V_{min} is project specific cover. If V_{min} is larger than V_{max} , contact VSL.

(4) X Minimum center spacing between anchorages

A.6.2.7 LOCAL ANCHORAGE ZONE REINFORCEMENT TYPE E @ 28/35 MPa

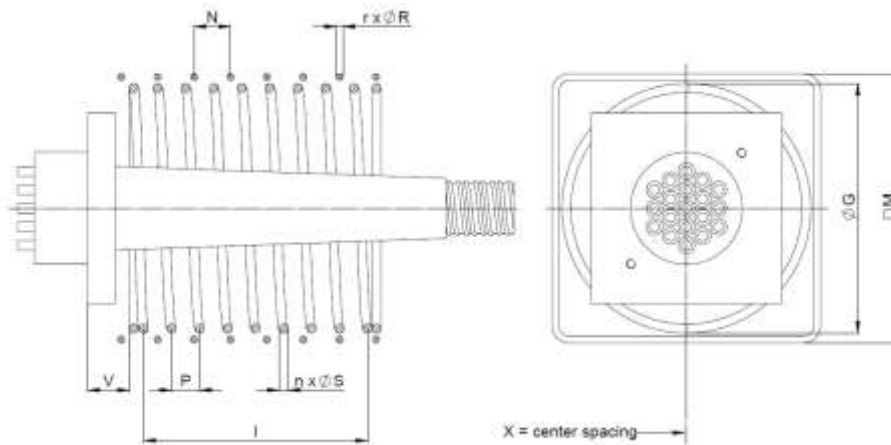

Figure 30 Local anchorage zone reinforcement type E @ 28/35 MPa

Reinforcement for concrete with $f_{c,min(t)} \geq 28/35 \text{ N/mm}^2$ (cylinder/cube) at time of stressing

Unit	COMBINATION SPIRAL + STIRRUPS									ALTERNATIVE SPIRAL ONLY					$V_{max}^{(3)}$	$X^{(4)}$
	SPIRAL REINF.					+ STIRRUPS				$\emptyset S$	$n^{(1)}$	P	$\emptyset G$	I		
	$\emptyset S$	$n^{(1)}$	P	$\emptyset G$	I	$\emptyset R$	r ⁽²⁾	N	M							
6-1	10	5	65	90	195	-	-	-	-	10	5	65	90	195	40	110
6-2	12	5	60	135	180	-	-	-	-	12	5	60	135	180	40	155
6-3	12	5	55	165	165	-	-	-	-	12	5	55	165	165	45	185
6-4	12	6	50	195	200	-	-	-	-	12	6	50	195	200	50	215
6-7	12	6	50	225	200	12	5	75	260	16	5	65	260	195	60	280
6-12	16	7	65	315	325	12	6	75	350	16	8	50	350	300	70	370
6-15	16	7	65	345	325	16	6	75	390	20	7	70	390	350	75	410
6-19	16	8	60	395	360	16	7	75	440	20	8	65	440	390	80	460
6-22	16	10	50	430	400	16	7	75	475	20	9	55	475	385	85	495
6-27	16	11	50	485	450	16	9	65	530	20	10	55	530	440	90	550
6-31	16	11	50	525	450	16	10	60	570	20	12	50	570	500	95	590
6-37	20	11	60	580	540	16	9	75	625	25	9	70	625	490	105	645
6-43	20	12	55	630	550	16	11	65	675	25	11	65	675	585	110	695
6-55	20	14	55	720	660	16	14	55	765	25	13	60	765	660	125	785

All dimensions in [mm]. Two possibilities are given for reinforcement: either a combination of spiral and stirrups (orthogonal reinforcement) or an alternative with spiral reinforcement only. Other combinations with equivalent performance (to be approved by VSL) are also possible.

Reinforcement steel $f_{yk} \geq 500 \text{ N/mm}^2$

- (1) n Number of turns including first and last turn required for anchorage of spiral. First spiral turn (bearing plate) tied back to adjacent one.
- (2) r Number of reinforcement layers
- (3) $V_{max} \geq V \geq V_{min}$; V_{min} is project specific cover. If V_{min} is larger than V_{max} , contact VSL.
- (4) X Minimum center spacing between anchorages

A.6.2.8 LOCAL ANCHORAGE ZONE REINFORCEMENT TYPE E @ 32/40 MPa

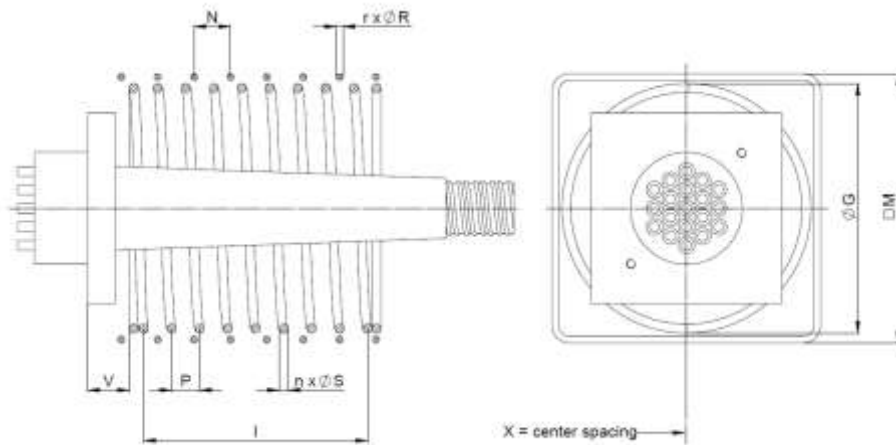

Figure 31 Local anchorage zone reinforcement type E @ 32/40 MPa

Reinforcement for concrete with $f_{c,min(t)} \geq 32/40 \text{ N/mm}^2$ (cylinder/cube) at time of stressing

Unit	COMBINATION SPIRAL + STIRRUPS									ALTERNATIVE SPIRAL ONLY					$V_{max}^{(3)}$	$X^{(4)}$
	SPIRAL REINF.					+ STIRRUPS				$\emptyset S$	$n^{(1)}$	P	$\emptyset G$	I		
	$\emptyset S$	$n^{(1)}$	P	$\emptyset G$	I	$\emptyset R$	$r^{(2)}$	N	M							
6-1	10	5	65	85	195	-	-	-	-	10	5	65	85	195	40	105
6-2	12	5	60	125	180	-	-	-	-	12	5	60	125	180	40	145
6-3	12	6	50	155	200	-	-	-	-	12	6	50	155	200	45	175
6-4	12	6	45	180	180	-	-	-	-	12	6	45	180	180	50	200
6-7	12	7	45	210	225	12	5	65	245	16	5	60	245	180	55	265
6-12	16	7	55	290	275	12	6	60	325	20	6	70	325	280	65	345
6-15	16	8	55	320	330	16	7	60	365	20	7	60	365	300	70	385
6-19	16	8	55	370	330	16	8	60	415	20	8	55	415	330	75	435
6-22	16	10	45	400	360	16	8	60	445	20	9	50	445	350	80	465
6-27	16	11	45	450	405	16	10	50	495	20	11	45	495	405	85	515
6-31	16	12	45	490	450	16	12	45	535	25	8	70	535	420	90	555
6-37	20	11	55	540	495	16	11	55	585	25	9	65	585	455	100	605
6-43	20	13	50	585	550	16	14	45	630	25	11	55	630	495	105	650
6-55	20	14	50	670	600	16	18	40	715	25	14	50	715	600	120	735

All dimensions in [mm]. Two possibilities are given for reinforcement: either a combination of spiral and stirrups (orthogonal reinforcement) or an alternative with spiral reinforcement only. Other combinations with equivalent performance (to be approved by VSL) are also possible.

Reinforcement steel $f_{yk} \geq 500 \text{ N/mm}^2$

- (1) n Number of turns including first and last turn required for anchorage of spiral. First spiral turn (bearing plate) tied back to adjacent one.
- (2) r Number of reinforcement layers
- (3) $V_{max} \geq V \geq V_{min}$; V_{min} is project specific cover. If V_{min} is larger than V_{max} , contact VSL.
- (4) X Minimum center spacing between anchorages

A.6.2.9 LOCAL ANCHORAGE ZONE REINFORCEMENT TYPE E @ 36/45 MPa

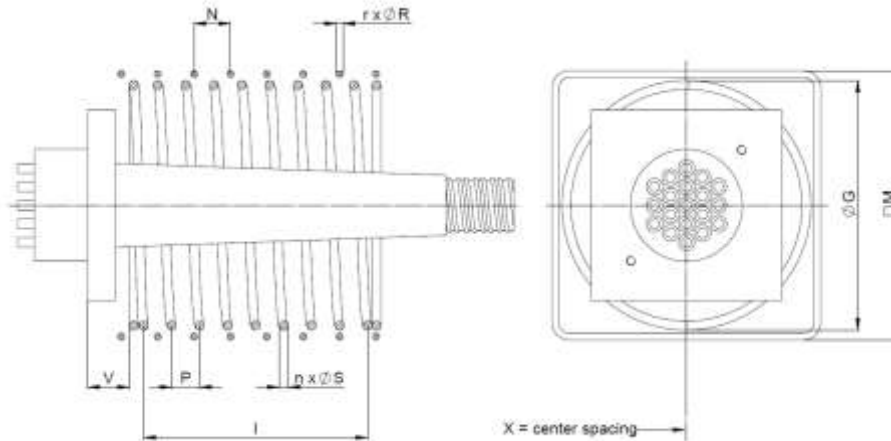

Figure 32 Local anchorage zone reinforcement type E @ 36/45 MPa

Reinforcement for concrete with $f_{c,min(t)} \geq 36/45 \text{ N/mm}^2$ (cylinder/cube) at time of stressing

Unit	COMBINATION SPIRAL + STIRRUPS									ALTERNATIVE SPIRAL ONLY					$V_{max}^{(3)}$	$X^{(4)}$
	SPIRAL REINF.					+ STIRRUPS										
	$\varnothing S$	$n^{(1)}$	P	$\varnothing G$	I	$\varnothing R$	$r^{(2)}$	N	M	$\varnothing S$	$n^{(1)}$	P	$\varnothing G$	I		
6-1	10	5	65	75	195	-	-	-	-	10	5	65	75	195	40	95
6-2	12	5	55	115	165	-	-	-	-	12	5	55	115	165	40	135
6-3	12	5	50	145	150	-	-	-	-	12	5	50	145	150	45	165
6-4	12	6	45	170	180	-	-	-	-	12	6	45	170	180	50	190
6-7	16	6	65	195	260	12	4	80	230	16	5	60	230	180	55	250
6-12	16	7	50	270	250	12	5	70	305	20	6	65	305	260	65	325
6-15	16	8	50	300	300	16	6	70	345	20	7	60	345	300	70	365
6-19	16	8	50	345	300	16	7	60	390	20	8	55	390	330	75	410
6-22	16	10	45	375	360	16	8	55	420	20	9	50	420	350	80	440
6-27	16	11	45	425	405	16	10	50	470	20	11	45	470	405	85	490
6-31	16	11	45	460	405	16	12	45	505	25	8	70	505	420	90	525
6-37	20	11	50	505	450	16	10	60	550	25	9	60	550	420	100	570
6-43	20	12	50	545	500	20	10	65	595	25	11	55	595	495	105	615
6-55	20	13	50	625	550	20	12	60	675	25	13	50	675	550	120	695

All dimensions in [mm]. Two possibilities are given for reinforcement: either a combination of spiral and stirrups (orthogonal reinforcement) or an alternative with spiral reinforcement only. Other combinations with equivalent performance (to be approved by VSL) are also possible.

Reinforcement steel $f_{yk} \geq 500 \text{ N/mm}^2$

- (1) n Number of turns including first and last turn required for anchorage of spiral. First spiral turn (bearing plate) tied back to adjacent one.
- (2) r Number of reinforcement layers
- (3) $V_{max} \geq V \geq V_{min}$; V_{min} is project specific cover. If V_{min} is larger than V_{max} , contact VSL.
- (4) X Minimum center spacing between anchorages

A.6.2.10 LOCAL ANCHORAGE ZONE REINFORCEMENT TYPE E @ 43/53 MPa

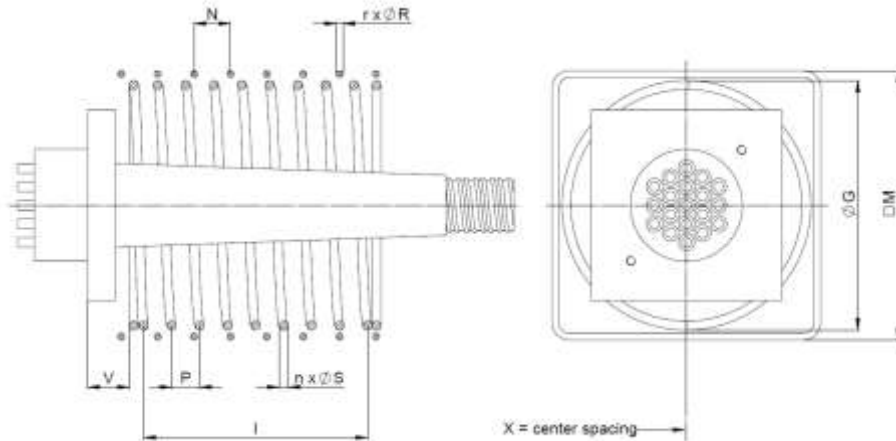

Figure 33 Local anchorage zone reinforcement type E @ 43/53 MPa

Reinforcement for concrete with $f_{c,min(t)} \geq 43/53 \text{ N/mm}^2$ (cylinder/cube) at time of stressing

Unit	COMBINATION SPIRAL + STIRRUPS									ALTERNATIVE SPIRAL ONLY					$V_{max}^{(3)}$	$X^{(4)}$
	SPIRAL REINF.					+ STIRRUPS										
	$\varnothing S$	$n^{(1)}$	P	$\varnothing G$	I	$\varnothing R$	$r^{(2)}$	N	M	$\varnothing S$	$n^{(1)}$	P	$\varnothing G$	I		
6-1	10	5	50	70	150	-	-	-	-	10	5	50	70	150	40	95
6-2	12	5	50	110	150	-	-	-	-	12	5	50	110	150	40	130
6-3	14	5	65	135	195	-	-	-	-	14	5	65	135	195	45	155
6-4	16	5	70	160	210	-	-	-	-	16	5	70	160	210	50	180
6-7	16	6	55	220	220	-	-	-	-	16	6	55	220	220	55	240
6-12	16	7	50	260	250	12	7	50	295	16	7	45	295	225	65	315
6-15	16	7	50	280	250	16	7	50	330	16	9	40	330	280	70	350
6-19	20	7	60	320	300	16	6	75	370	20	7	55	370	275	75	390
6-22	20	8	60	350	360	16	9	50	400	20	8	50	400	300	80	420
6-27	20	8	60	390	360	20	8	65	445	20	10	45	445	360	85	465
6-31	20	9	60	430	420	20	8	65	480	20	11	45	480	405	90	500
6-37	20	10	55	480	440	20	9	60	530	25	9	65	530	455	95	550
6-43	25	9	65	510	455	20	10	60	560	25	10	55	565	440	100	585
6-55	25	10	65	590	520	20	11	60	640	25	12	55	640	550	110	660

All dimensions in [mm]. Two possibilities are given for reinforcement: either a combination of spiral and stirrups (orthogonal reinforcement) or an alternative with spiral reinforcement only. Other combinations with equivalent performance (to be approved by VSL) are also possible.

Reinforcement steel $f_{yk} \geq 500 \text{ N/mm}^2$

- (1) n Number of turns including first and last turn required for anchorage of spiral. First spiral turn (bearing plate) tied back to adjacent one.
- (2) r Number of reinforcement layers
- (3) $V_{max} \geq V \geq V_{min}$; V_{min} is project specific cover. If V_{min} is larger than V_{max} , contact VSL.
- (4) X Minimum center spacing between anchorages

A.6.3 ANCHORAGES TYPE CS

A.6.3.1 CATEGORIES OF USE AND ARRANGEMENTS

Anchorage cast in concrete structure

- STANDARD Unit

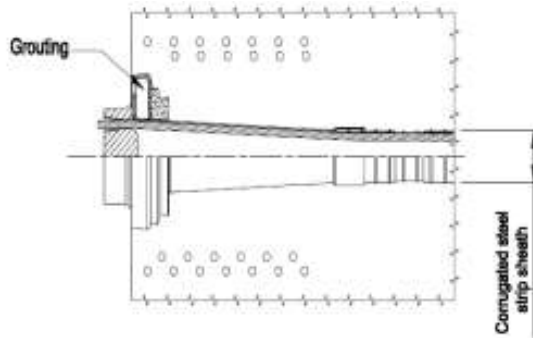

- PLUS Unit (encapsulated)

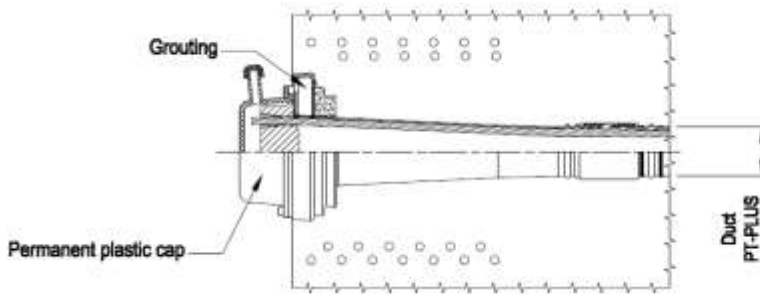

- SUPER Unit (Electrically Isolated Tendon)

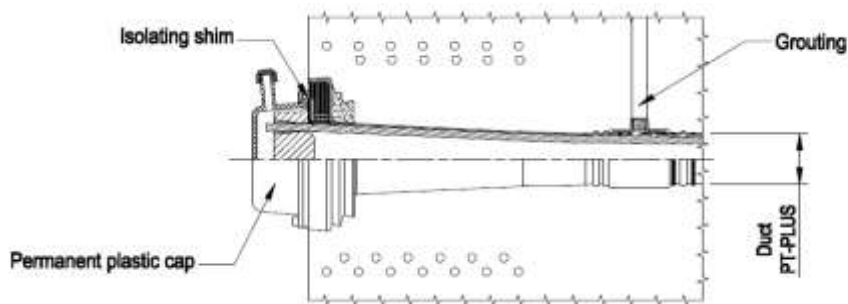

Figure 34 Arrangements anchorage type CS cast in concrete structure

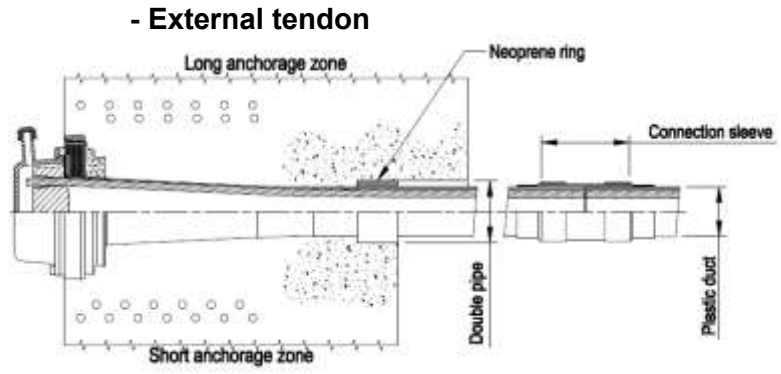

Figure 35 Arrangements anchorage type CS external tendon

A.6.3.2 ANCHORAGES TYPE CS @ 28/35 MPa

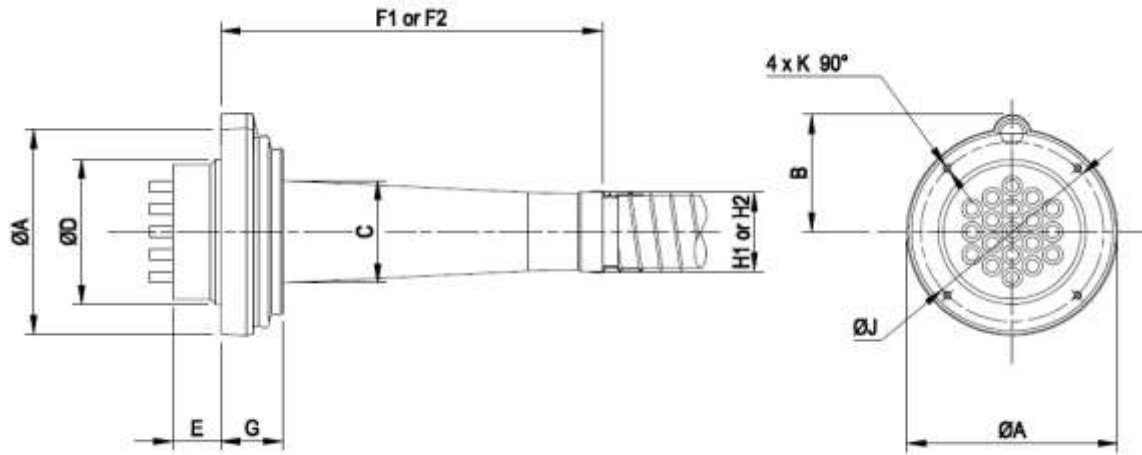

Figure 36 Anchorages type CS @28/35 MPa dimensions

Unit	ØA	B	C	ØD	E	F1 ⁽¹⁾	F2 ⁽²⁾	G	H1 ⁽¹⁾	H2 ⁽²⁾	ØJ ⁽³⁾	K
6-7	222	136	85	143	50	225	360	60	80	63	188	M12
6-12	258	149	117	178	60	392	530	80	95	81	220	M12
6-19	300	170	148	210	70	540	660	90	110	106	260	M12
6-22	320	180	165	228	70	570	740	100	125	106	274	M12
6-27	360	203	181	256	69	660	810	110	139	121	310	M16
6-31	390	217	188	274	69	620	740	122	149	136	330	M16
6-37	420	236	211	300	82	805	925	130	149	136	357	M16

All dimensions in [mm]

⁽¹⁾ for STANDARD

⁽²⁾ for PLUS or SUPER

⁽³⁾ J spacing of holes for fixation to formwork

A.6.3.3 LOCAL ANCHORAGE ZONE REINFORCEMENT TYPE CS @ 28/35 MPa

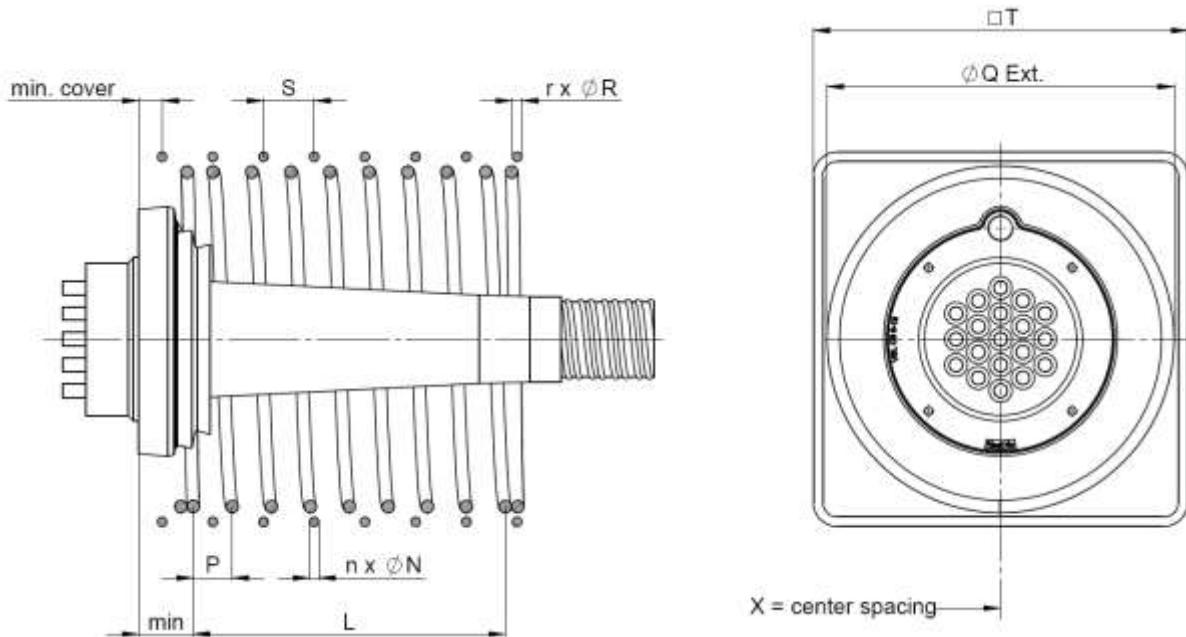

Figure 37 Local anchorage zone reinforcement type CS @ 28/35 MPa

Reinforcement for concrete with $f_{c, \min(t)} \geq 28/35 \text{ N/mm}^2$ (cylinder/cube) when stressing

Unit	SPIRAL REINFORCEMENT					ORTHOGONAL REINF.				X
	ØN	n ⁽¹⁾	P	ØQ	L	ØR	r ⁽²⁾	S	T	
6-7	12	6	60	260	240	10	7	50	295	315
6-12	16	7	65	345	325	12	9	60	390	410
6-19	16	9	60	450	420	16	11	65	495	515
6-22	16	10	60	490	480	16	11	75	535	555
6-27	16	11	55	545	495	16	11	50	595	615
6-31	16	12	55	585	550	16	12	45	635	655
6-37	20	11	65	645	585	16	13	50	695	715

All dimensions in [mm]. Reinforcement consists of a combination of spiral and stirrups. Other combinations with equivalent performance (to be approved by VSL) are also possible.

Reinforcement steel $f_{yk} \geq 500 \text{ N/mm}^2$.

⁽¹⁾ n Number of turns including first and last turn required for anchorage of spiral

⁽²⁾ r Number of reinforcement layers

A.6.4 ANCHORAGES TYPE GC

A.6.4.1 CATEGORIES OF USE AND ARRANGEMENTS

- Internal bonded Post-Tensioning

- STANDARD Unit

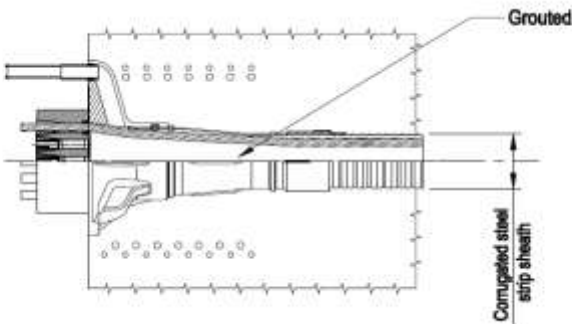

- PLUS Unit

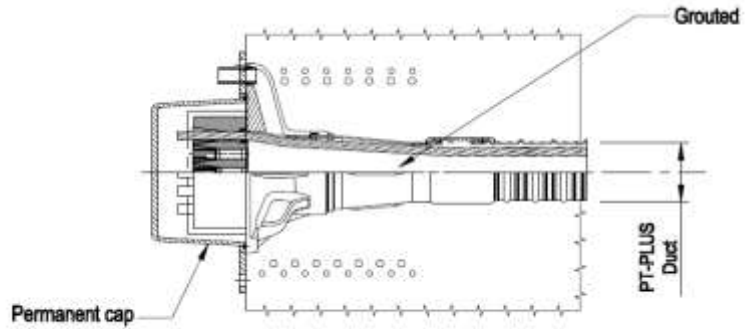

- External Tendon

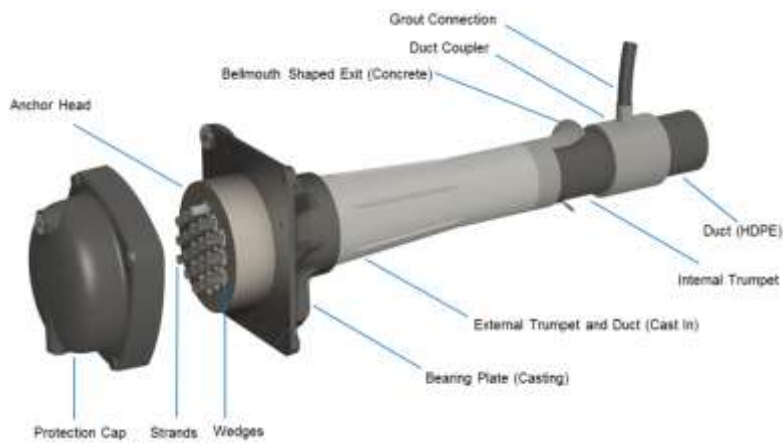

- Electrically Isolated Tendon (EIT)

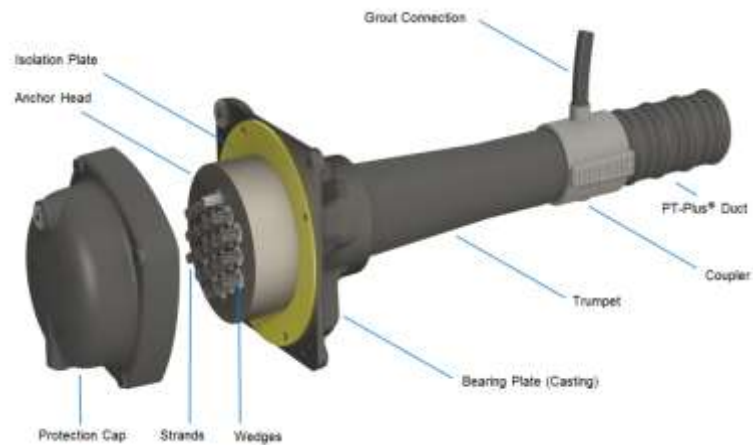

Figure 38 Categories of use and arrangements anchorage type GC

A.6.4.2 ANCHORAGES TYPE GC

A.6.4.2.1 Standard bonded Post-Tensioning

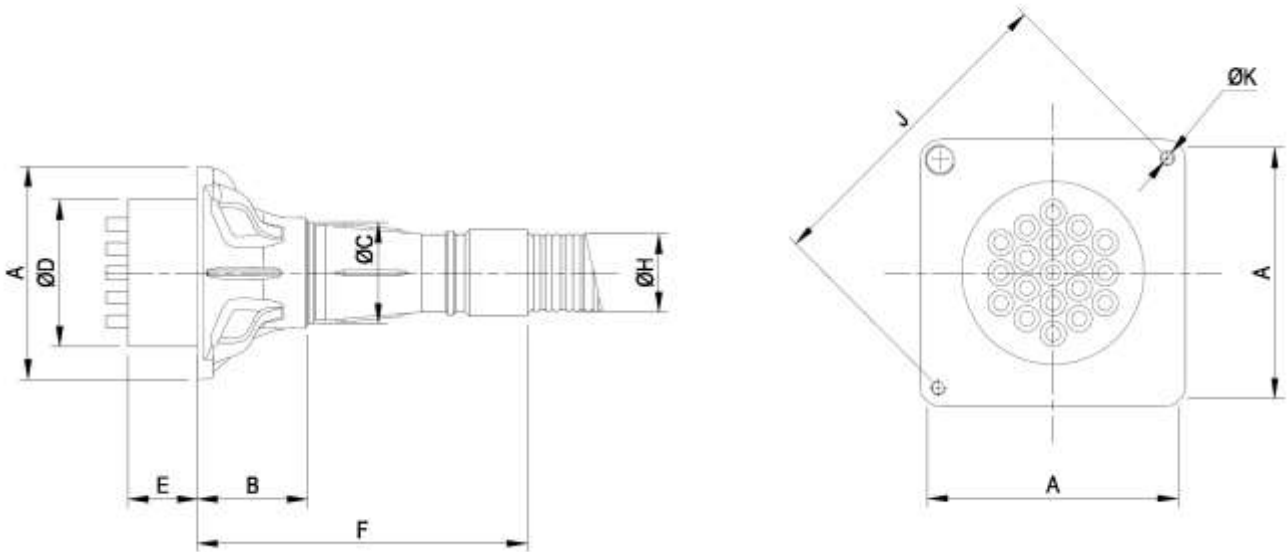

Figure 39 Anchorages type GC standard bonded post-tensioning dimensions

Unit	□A	B	ØC	Anchor heads E/EP ⁽³⁾		Anchor heads E(QT)/EP(QT) ⁽³⁾		F	ØH	J ⁽¹⁾	K
				ØD	E	ØD	E				
6-3	130	120	50	95	50	95	50	120 ⁽²⁾	50	140	M12
6-4	140	120	60	110	55	106	50	120 ⁽²⁾	60	154	M12
6-7	180	135	76	135	60	135	55	135 ⁽²⁾	76	210	M12
6-12	230	220	92	170	75	166	62	220 ⁽²⁾	92	264	M16
6-15	260	240	113	190	85	186	68	240 ⁽²⁾	113	316	M16
6-19	290	150	131	200	95	196	73	450	112	354	M16
6-22	320	150	153	220	100	216	78	640	112	400	M16
6-27	350	170	164	240	110	236	85	620	127	430	M16
6-31	375	170	173	260	120	256	90	580	143	470	M16
6-37	410	170	196	280	135	276	98	770	142	524	M16
6-43	470	180	230	320	145	316	105	935	166	420	M20
6-55	520	180	240	340	160	340	118	1035	166	452	M20

All dimensions in [mm]. Dimensions correspond to anchorages with bare strands. For dimensions with sheathed protected strands, check with VSL.

- (1) J spacing of holes for fixation to formwork
- (2) These units do not have a trumpet
- (3) ØD, E outer dimensions of E and EP – or E(QT) and EP(QT) - are identical

A.6.4.2.2 External Tendons

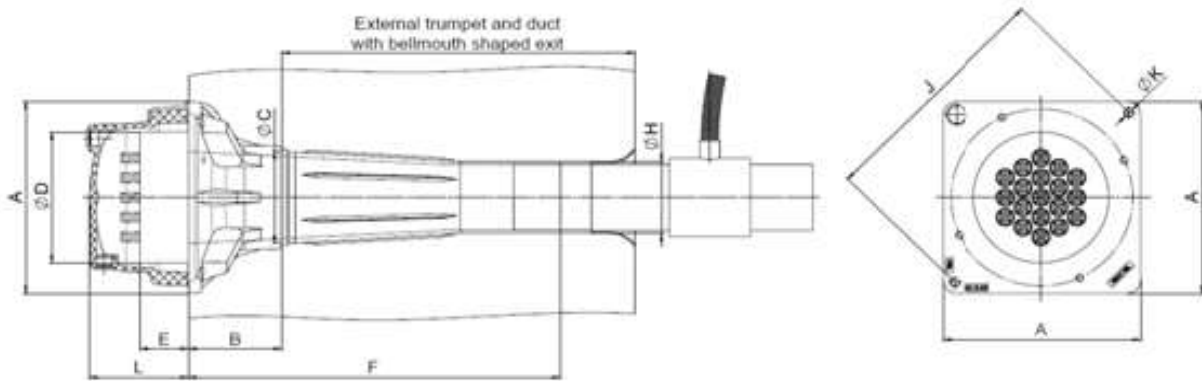

Figure 40 Anchorages type GC external tendons dimensions

Unit	□A	B	ØC	ØD	E	F	ØH	J ⁽¹⁾	K	L
6-3	180	135	76	116	55	200	50	210	M12	120
6-4	180	135	76	116	55	200	50	210	M12	120
6-7	230	220	92	148	62	300	75	264	M16	135
6-12	260	240	113	186	68	330	90	316	M16	145
6-15	290	150	131	196	73	405	110	354	M16	155
6-19	320	150	153	218	78	525	110	400	M16	160
6-22	350	170	164	236	85	525	125	430	M16	170
6-27	375	170	173	248	90	505	125	470	M16	180
6-31	410	170	196	276	98	730	140	524	M16	200
6-37	470	180	230	316	105	965	140	420	M20	215
6-43	520	180	240	326	118	965	160	452	M20	230

All dimensions in [mm]. Dimensions correspond to anchorages with bare strands. For dimensions with sheathed protected strands, check with VSL.

⁽¹⁾ J spacing of holes for fixation to formwork

A.6.4.2.3 Electrically Isolated Tendons

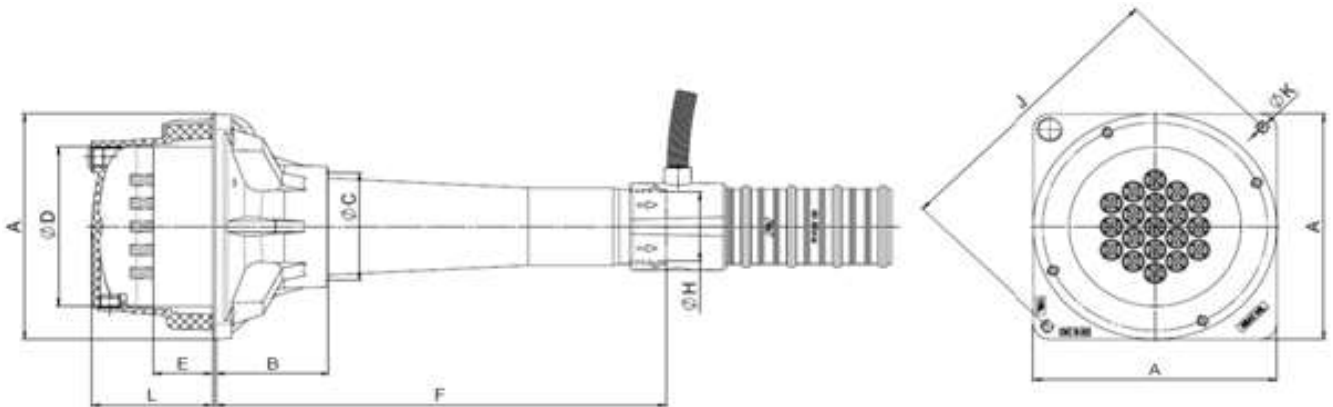

Figure 41 Anchorages type GC electrically isolated tendons dimensions

Unit	□A	B	ØC	ØD	E	F	ØH	J ⁽¹⁾	K	L
6-3	180	135	76	116	55	245	58	210	M12	120
6-4	180	135	76	116	55	245	58	210	M12	120
6-7	230	220	92	156	62	375	58	264	M16	135
6-12	260	240	113	186	68	400	76	316	M16	145
6-15	290	150	131	198	73	475	85	354	M16	155
6-19	320	150	153	226	78	595	100	400	M16	160
6-22	350	170	164	246	85	595	100	430	M16	170
6-27	375	170	173	258	90	575	115	470	M16	180
6-31	410	170	196	286	98	800	130	524	M16	200
6-37	470	180	230	326	105	1035	130	420	M20	215
6-43	520	180	240	336	118	1035	150	452	M20	230

All dimensions in [mm]. Dimensions correspond to anchorages with bare strands. For dimensions with sheathed protected strands, check with VSL.

⁽¹⁾ J spacing of holes for fixation to formwork

A.6.4.3 LOCAL ANCHORAGES ZONE REINFORCEMENT TYPE GC

A.6.4.3.1 ANCHORAGES TYPE GC – Internal bonded PT

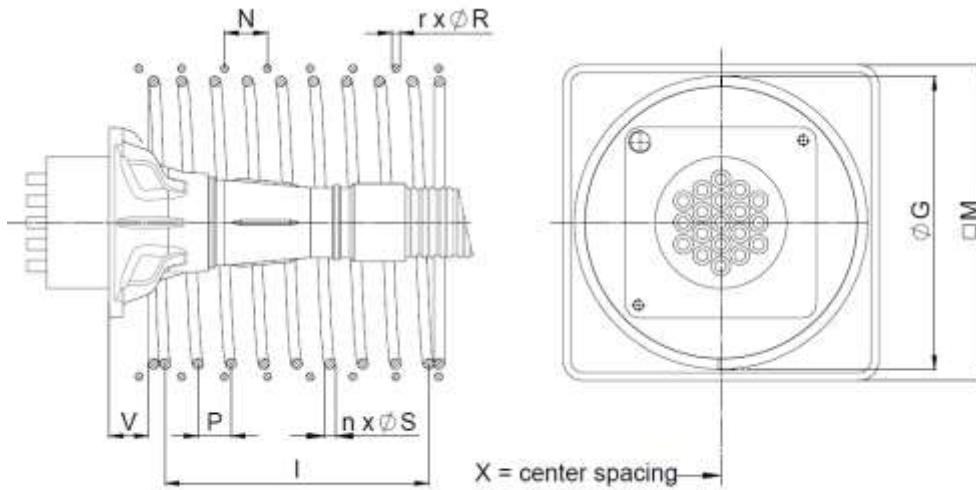

Figure 42 Local anchorage zone reinforcement type GC internal bonded post-tensioning

Reinforcement for concrete with $f_{c, \min(t)} \geq 25/30 \text{ N/mm}^2$ (cylinder/cube) at time of stressing

Unit	SPIRAL REINFORCEMENT					ORTHOGONAL REINF.				$V_{\max}^{(3)}$	$X^{(4)}$
	$\varnothing S$	$n^{(1)}$	P	$\varnothing G$	l	$\varnothing R$	$r^{(2)}$	N	M		
6-3	10	5	50	150	150	8	4	60	180	45	200
6-4	12	5	60	180	180	8	5	50	210	45	230
6-7	12	7	50	250	250	10	6	55	280	45	305
6-12	16	7	60	345	300	10	5	85	380	50	400
6-15	16	9	50	395	350	8	7	70	425	50	440
6-19	16	10	50	445	400	12	7	70	480	50	495
6-22	20	9	60	480	420	10	6	100	515	50	535
6-27	16	12	50	530	500	16	9	65	570	50	590
6-31	16	13	50	570	550	16	11	60	615	50	635
6-37	20	11	60	630	540	16	10	70	670	50	690

All dimensions in [mm]. Reinforcement consists of a combination of spiral and stirrups. Other combinations with equivalent performance (to be approved by VSL) are also possible.

Reinforcement steel $f_{yk} \geq 500 \text{ N/mm}^2$.

(1) n Number of turns including first and last turn required for anchorage of spiral. First spiral turn (bearing plate) tied back to adjacent one.

(2) r Number of reinforcement layers

(3) $V_{\max} \geq V \geq V_{\min}$; V_{\min} is project specific cover. If V_{\min} is larger than V_{\max} , contact VSL.

(4) X Minimum center spacing between anchorages

VSL Post-Tensioning System

Reinforcement for concrete with $f_{c,min(t)} \geq 28/35 \text{ N/mm}^2$ (cylinder/cube) at time of stressing

Unit	SPIRAL REINFORCEMENT					ORTHOGONAL REINF.				$V_{max}^{(3)}$	$X^{(4)}$
	$\varnothing S$	$n^{(1)}$	P	$\varnothing G$	l	$\varnothing R$	$r^{(2)}$	N	M		
6-3	10	5	50	140	150	8	4	55	165	45	185
6-4	12	5	60	170	180	8	5	50	195	45	215
6-7	12	6	50	230	200	10	6	50	260	45	280
6-12	16	7	60	320	300	10	6	75	350	50	370
6-15	16	9	50	365	350	8	9	50	390	50	410
6-19	16	9	50	410	350	12	9	55	440	50	460
6-22	20	9	60	445	420	10	7	80	475	50	495
6-27	16	11	50	490	450	16	9	60	530	50	550
6-31	16	13	45	530	495	16	10	60	570	50	590
6-37	20	12	55	585	550	16	9	80	625	50	645
6-43	26	12	65	730	650	-	-	-	-	50	750
6-55	26	14	60	825	720	-	-	-	-	50	845

Reinforcement for concrete with $f_{c,min(t)} \geq 32/40 \text{ N/mm}^2$ (cylinder/cube) at time of stressing

Unit	SPIRAL REINFORCEMENT					ORTHOGONAL REINF.				$V_{max}^{(3)}$	$X^{(4)}$
	$\varnothing S$	$n^{(1)}$	P	$\varnothing G$	l	$\varnothing R$	$r^{(2)}$	N	M		
6-3	12	5	55	155	165	-	-	-	-	45	175
6-4	12	6	45	180	180	-	-	-	-	45	200
6-7	12	6	50	215	200	10	6	50	245	45	265
6-12	16	7	55	295	275	10	5	90	325	50	345
6-15	16	8	50	335	300	10	7	65	365	50	385
6-19	16	10	45	375	360	12	7	65	410	50	430
6-22	20	8	60	410	360	12	6	85	445	50	465
6-27	16	11	45	455	405	16	8	65	495	50	515
6-31	16	12	45	490	450	16	10	55	530	50	550
6-37	20	12	50	540	500	16	8	85	580	50	600

All dimensions in [mm]. Reinforcement consists of a combination of spiral and stirrups. Other combinations with equivalent performance (to be approved by VSL) are also possible.

Reinforcement steel $f_{yk} \geq 500 \text{ N/mm}^2$.

- (1) n Number of turns including first and last turn required for anchorage of spiral. First spiral turn (bearing plate) tied back to adjacent one.
- (2) r Number of reinforcement layers
- (3) $V_{max} \geq V \geq V_{min}$; V_{min} is project specific cover. If V_{min} is larger than V_{max} , contact VSL.
- (4) X Minimum center spacing between anchorages

VSL Post-Tensioning System

Reinforcement for concrete with $f_{c,min(t)} \geq 36/45 \text{ N/mm}^2$ (cylinder/cube) at time of stressing

Unit	SPIRAL REINFORCEMENT					ORTHOGONAL REINF.				$V_{max}^{(3)}$	$X^{(4)}$
	$\emptyset S$	$n^{(1)}$	P	$\emptyset G$	l	$\emptyset R$	$r^{(2)}$	N	M		
6-3	12	5	55	145	165	-	-	-	-	45	165
6-4	12	6	45	170	180	-	-	-	-	45	190
6-7	16	6	65	230	260	-	-	-	-	45	250
6-12	16	8	50	305	300	-	-	-	-	50	325
6-15	16	8	50	315	300	10	6	65	345	50	365
6-19	16	9	45	355	315	12	7	65	390	50	410
6-22	20	8	60	385	360	12	6	70	420	50	440
6-27	16	11	45	425	405	16	8	60	465	50	485
6-31	16	11	45	460	405	16	10	50	500	50	520
6-37	20	10	55	510	440	16	10	60	550	50	570

Reinforcement for concrete with $f_{c,min(t)} \geq 40/50 \text{ N/mm}^2$ (cylinder/cube) at time of stressing

Unit	SPIRAL REINFORCEMENT					ORTHOGONAL REINF.				$V_{max}^{(3)}$	$X^{(4)}$
	$\emptyset S$	$n^{(1)}$	P	$\emptyset G$	l	$\emptyset R$	$r^{(2)}$	N	M		
6-3	12	5	50	135	150	-	-	-	-	45	155
6-4	12	6	40	160	160	-	-	-	-	45	180
6-7	16	6	60	220	240	-	-	-	-	45	240
6-12	16	7	50	295	250	-	-	-	-	50	315
6-15	20	7	60	330	300	-	-	-	-	50	350
6-19	16	8	50	335	300	12	8	50	370	50	390
6-22	20	7	60	370	300	12	7	65	400	50	420
6-27	20	8	60	400	360	16	6	85	445	50	465
6-31	20	9	60	435	420	16	7	75	480	50	500
6-37	20	9	60	480	420	20	7	80	530	50	550

All dimensions in [mm]. Reinforcement consists of a combination of spiral and stirrups. Other combinations with equivalent performance (to be approved by VSL) are also possible.

Reinforcement steel $f_{yk} \geq 500 \text{ N/mm}^2$.

- (1) n Number of turns incl. first and last turn required for anchorage of spiral. First spiral turn (bearing plate) tied back to adjacent one.
- (2) r Number of reinforcement layers
- (3) $V_{max} \geq V \geq V_{min}$; V_{min} is project specific cover. If V_{min} is larger than V_{max} , contact VSL.
- (4) X Minimum center spacing between anchorages

**A.6.4.3.2 ANCHORAGES TYPE GC –
External and electrically isolated tendons**

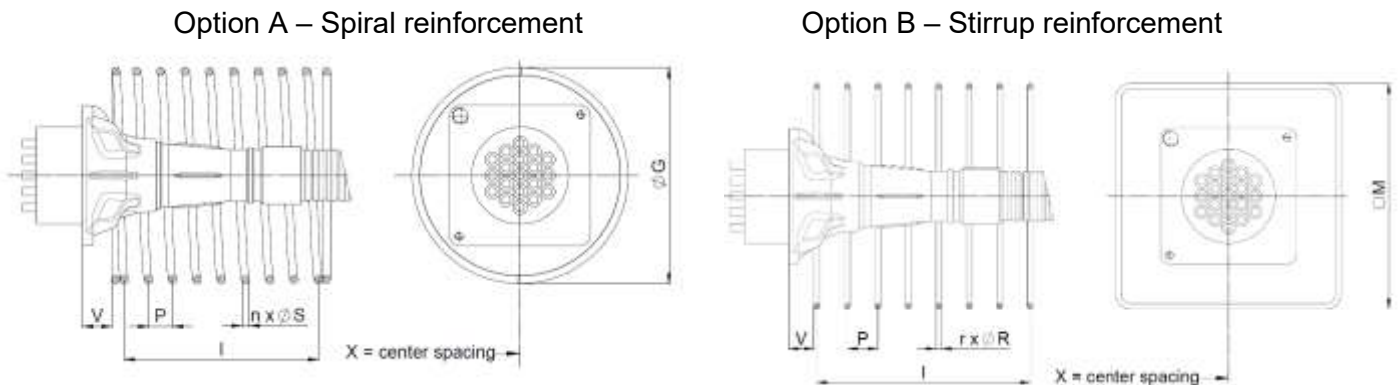

Figure 43 Local anchorage zone reinforcement type GC external and electrically isolated tendons

Reinforcement for concrete with $f_{c,min(t)} \geq 25/30 \text{ N/mm}^2$ (cylinder/cube) at time of stressing

Unit	A-SPIRAL REINFORCEMENT							B – STIRRUP REINFORCEMENT						
	I	P	ØS	ØG	n ⁽¹⁾	V _{max} ⁽³⁾	X ⁽⁴⁾	I	P	ØR	M	r ⁽²⁾	V _{max} ⁽³⁾	X ⁽⁴⁾
6-3	260	65	10	200	6	45	220	280	70	12	210	5	45	230
6-4	275	55	12	215	7	45	235	200	40	12	215	6	45	235
6-7	320	40	12	285	10	50	305	300	50	16	285	7	50	305
6-12	385	55	16	380	9	50	400	360	60	20	380	7	50	400
6-15	440	40	16	425	13	50	445	405	45	20	425	10	50	445
6-19	480	40	16	480	14	50	500	450	45	20	480	11	50	500
6-22	540	60	20	520	11	50	540	520	65	25	520	9	50	540
6-27	550	50	20	575	13	50	595	550	55	25	575	11	50	595
6-31	600	50	20	620	14	50	640	605	55	25	620	12	50	640
6-37	630	45	20	675	16	50	695	650	50	25	675	14	50	695

(1) n Number of turns including first and last turn required for anchorage of spiral. First spiral turn (bearing plate) tied back to adjacent one.

(2) r Number of reinforcement layers

(3) $V_{max} \geq V \geq V_{min}$; V_{min} is project specific cover. If V_{min} is larger than V_{max} , contact VSL.

(4) X Minimum center spacing between anchorages

All dimensions in [mm]. Two options (either spiral OR stirrup) are presented for reinforcement. Combinations of spiral and stirrups with equivalent performance (to be approved by VSL) are also possible.

Reinforcement steel $f_{yk} \geq 500 \text{ N/mm}^2$.

Strand $A_p = 150\text{mm}^2$, $f_{pk} = 1860 \text{ N/mm}^2$ (GUTS), $F_{pk} = 279 \text{ kN}$

VSL Post-Tensioning System

Reinforcement for concrete with $f_{c,min(t)} \geq 28/35 \text{ N/mm}^2$ (cylinder/cube) at time of stressing

Unit	A-SPIRAL REINFORCEMENT						
	I	P	ØS	ØG	n ⁽¹⁾	V _{max} ⁽³⁾	X ⁽⁴⁾
6-3	210	70	10	200	5	45	220
6-4	260	65	12	210	6	45	230
6-7	280	40	12	265	9	50	285
6-12	400	50	16	350	10	50	370
6-15	400	40	16	395	12	50	415
6-19	440	40	16	445	13	50	465
6-22	495	55	20	480	11	50	500
6-27	540	45	20	530	14	50	550
6-31	550	50	20	575	13	50	595
6-37	630	45	20	625	16	50	645
6-43	660	60	25	675	13	50	695

B – STIRRUP REINFORCEMENT						
I	P	ØR	M	r ⁽²⁾	V _{max} ⁽³⁾	X ⁽⁴⁾
280	70	12	210	5	45	230
350	70	16	220	6	45	240
250	50	16	265	6	50	285
330	55	20	350	7	50	370
360	45	20	395	9	50	415
420	70	25	445	7	50	465
480	60	25	480	9	50	500
500	50	25	530	11	50	550
550	55	25	575	11	50	595
640	80	32	625	9	50	645
630	70	32	675	10	50	695

Reinforcement for concrete with $f_{c,min(t)} \geq 32/40 \text{ N/mm}^2$ (cylinder/cube) at time of stressing

Unit	A-SPIRAL REINFORCEMENT						
	I	P	ØS	ØG	n ⁽¹⁾	V _{max} ⁽³⁾	X ⁽⁴⁾
6-3	210	70	8	200	5	45	220
6-4	210	70	12	210	5	45	230
6-7	270	45	12	260	8	50	280
6-12	350	50	16	325	9	50	345
6-15	400	40	16	370	12	50	390
6-19	420	60	20	415	9	50	435
6-22	495	55	20	450	11	50	470
6-27	495	45	20	495	13	50	515
6-31	540	45	20	535	14	50	555
6-37	630	70	25	585	11	50	605

B – STIRRUP REINFORCEMENT						
I	P	ØR	M	r ⁽²⁾	V _{max} ⁽³⁾	X ⁽⁴⁾
280	70	10	200	5	45	220
350	70	16	220	6	45	240
390	65	16	270	7	50	290
330	55	20	325	7	50	345
390	65	25	370	7	50	390
390	65	25	415	7	50	435
420	60	25	450	8	50	470
450	50	25	495	10	50	515
500	50	25	535	11	50	555
600	75	32	585	9	50	605

- (1) n Number of turns including first and last turn required for anchorage of spiral. First spiral turn (bearing plate) tied back to adjacent one.
- (2) r Number of reinforcement layers
- (3) $V_{max} \geq V \geq V_{min}$; V_{min} is project specific cover. If V_{min} is larger than V_{max} , contact VSL.
- (4) X Minimum center spacing between anchorages

All dimensions in [mm]. Two options (either spiral OR stirrup) are presented for reinforcement. Combinations of spiral and stirrups with equivalent performance (to be approved by VSL) are also possible.

Reinforcement steel $f_{yk} \geq 500 \text{ N/mm}^2$.
 Strand $A_p = 150\text{mm}^2$, $f_{pk} = 1860 \text{ N/mm}^2$ (GUTS), $F_{pk} = 279 \text{ kN}$

VSL Post-Tensioning System

Reinforcement for concrete with $f_{c,min(t)} \geq 36/45 \text{ N/mm}^2$ (cylinder/cube) at time of stressing

Unit	A-SPIRAL REINFORCEMENT						
	I	P	ØS	ØG	n ⁽¹⁾	V _{max} ⁽³⁾	X ⁽⁴⁾
6-3	210	70	8	200	5	45	220
6-4	220	55	10	200	6	45	220
6-7	275	55	12	260	7	50	280
6-12	350	50	16	310	9	50	330
6-15	360	40	16	350	11	50	370
6-19	400	40	16	395	12	50	415
6-22	440	55	20	425	10	50	445
6-27	495	45	20	470	13	50	490
6-31	495	45	20	505	13	50	525
6-37	585	65	25	550	11	50	570

B – STIRRUP REINFORCEMENT						
I	P	ØR	M	r ⁽²⁾	V _{max} ⁽³⁾	X ⁽⁴⁾
280	70	8	200	5	45	220
325	65	12	210	6	45	230
350	70	16	270	6	50	290
330	55	20	310	7	50	330
325	65	25	350	6	50	370
390	65	25	395	7	50	415
420	60	25	425	8	50	445
450	50	25	470	10	50	490
500	50	25	505	11	50	525
525	75	32	550	8	50	570

Reinforcement for concrete with $f_{c,min(t)} \geq 40/50 \text{ N/mm}^2$ (cylinder/cube) at time of stressing

Unit	A-SPIRAL REINFORCEMENT						
	I	P	ØS	ØG	n ⁽¹⁾	V _{max} ⁽³⁾	X ⁽⁴⁾
6-3	210	70	8	200	5	45	220
6-4	260	65	10	200	6	45	220
6-7	300	60	12	260	7	50	280
6-12	350	50	16	295	9	50	315
6-15	360	40	16	330	11	50	350
6-19	400	40	16	375	12	50	395
6-22	440	55	20	405	10	50	425
6-27	450	45	20	445	12	50	465
6-31	495	45	20	480	13	50	500
6-37	560	70	25	525	10	50	545

B – STIRRUP REINFORCEMENT						
I	P	ØR	M	r ⁽²⁾	V _{max} ⁽³⁾	X ⁽⁴⁾
280	70	8	200	5	45	220
275	55	10	210	6	45	230
350	50	12	270	8	50	290
375	55	20	300	8	50	320
420	60	25	340	8	50	360
390	65	25	375	7	50	395
420	60	25	405	8	50	425
480	80	32	445	7	50	465
450	50	25	480	10	50	500
560	70	32	540	10	50	560

- (1) n Number of turns including first and last turn required for anchorage of spiral. First spiral turn (bearing plate) tied back to adjacent one.
- (2) r Number of reinforcement layers
- (3) $V_{max} \geq V \geq V_{min}$; V_{min} is project specific cover. If V_{min} is larger than V_{max} , contact VSL.
- (4) X Minimum center spacing between anchorages

All dimensions in [mm]. Two options (either spiral OR stirrup) are presented for reinforcement. Combinations of spiral and stirrups with equivalent performance (to be approved by VSL) are also possible.

Reinforcement steel $f_{yk} \geq 500 \text{ N/mm}^2$.
 Strand $A_p = 150\text{mm}^2$, $f_{pk} = 1860 \text{ N/mm}^2$ (GUTS), $F_{pk} = 279 \text{ kN}$

VSL Post-Tensioning System

Reinforcement for concrete with $f_{c,min(t)} \geq 50/60 \text{ N/mm}^2$ (cylinder/cube) at time of stressing

Unit	A-SPIRAL REINFORCEMENT							B – STIRRUP REINFORCEMENT						
	I	P	ØS	ØG	n ⁽¹⁾	V _{max} ⁽³⁾	X ⁽⁴⁾	I	P	ØR	M	r ⁽²⁾	V _{max} ⁽³⁾	X ⁽⁴⁾
6-3	210	70	8	200	5	45	220	280	70	8	200	5	45	220
6-4	210	70	8	200	5	45	220	275	55	8	200	6	45	220
6-7	300	60	10	250	7	50	270	375	75	12	260	6	50	280
6-12	300	60	16	300	7	50	320	390	65	20	300	7	50	320
6-15	325	65	20	330	7	50	350	450	75	25	340	7	50	360
6-19	360	60	20	360	8	50	380	490	70	25	370	8	50	390
6-22	385	55	20	390	9	50	410	480	60	25	400	9	50	420
6-27	420	70	25	430	8	50	450	560	80	32	440	8	50	470
6-31	490	70	25	460	9	50	480	595	85	32	480	8	50	500
6-37	490	70	25	520	9	50	540	595	85	32	540	8	50	560

- (1) n Number of turns including first and last turn required for anchorage of spiral. First spiral turn (bearing plate) tied back to adjacent one.
- (2) r Number of reinforcement layers
- (3) $V_{max} \geq V \geq V_{min}$; V_{min} is project specific cover. If V_{min} is larger than V_{max} , contact VSL.
- (4) X Minimum center spacing between anchorages

All dimensions in [mm]. Two options (either spiral OR stirrup) are presented for reinforcement. Combinations of spiral and stirrups with equivalent performance (to be approved by VSL) are also possible.

Reinforcement steel $f_{yk} \geq 500 \text{ N/mm}^2$.
 Strand $A_p = 150\text{mm}^2$, $f_{pk} = 1860 \text{ N/mm}^2$ (GUTS), $F_{pk} = 279 \text{ kN}$

A.6.5 ANCHORAGES TYPE NC AND NC-U

A.6.5.1 CATEGORIES OF USE AND ARRANGEMENTS

Anchorage cast in concrete structure

- NC STANDARD Unit (bonded)

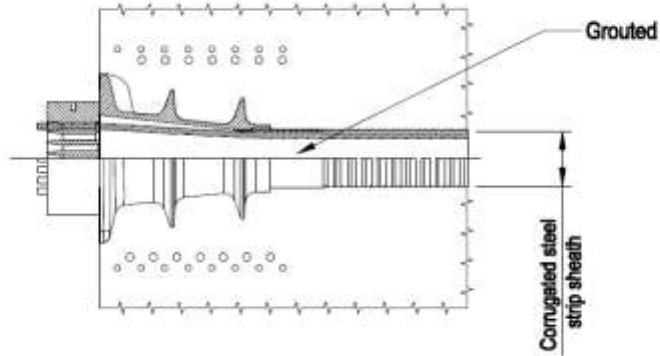

- NC PLUS Unit (bonded)

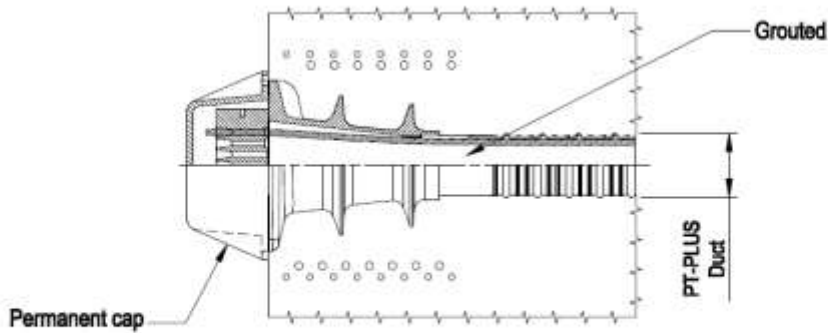

- NC-U STANDARD Unit (unbonded)

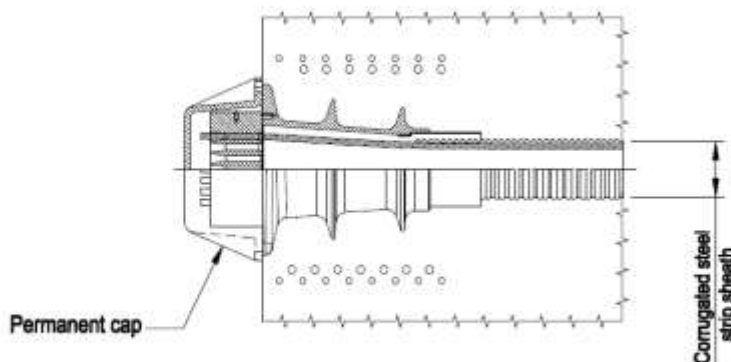

Figure 44 Categories of use arrangements anchorage type NC and NC-U

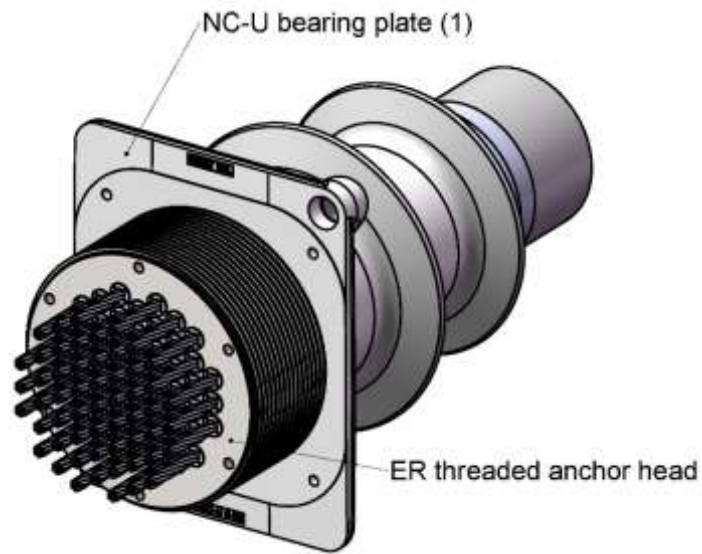

Figure 45 Assembly with threaded anchor head for load monitoring

- (1) A threaded anchor head type ER for load monitoring (E anchor head with external thread) is displayed on a NC-U bearing plate. Assembly of threaded anchor heads is also possible on NC, E, GC, or CS bearing plates

A.6.5.2 ANCHORAGES TYPE NC AND NC-U @ 53/64 MPa

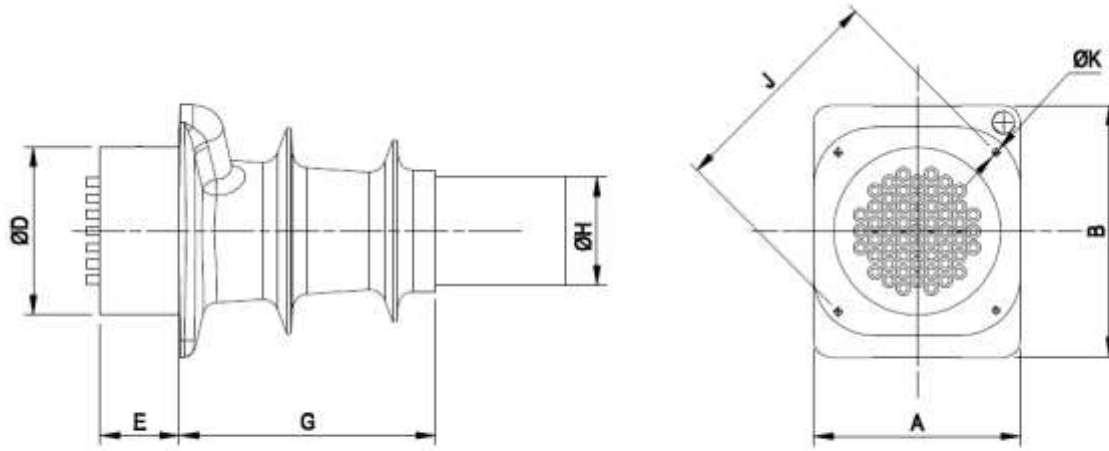

Figure 46 Anchorages type NC and NC-U @53/64 MPa dimensions

Type	Unit	A	B	G	Anchor heads E/EP ⁽²⁾		Anchor heads E(QT)/EP(QT) ⁽²⁾		ØH	J ⁽¹⁾	K
					ØD	E	ØD	E			
NC	6-55	420	510	520	340	160	340	118	183	452	M16
NC-U	6-55	420	510	520	340	160	340	118	223	452	M16

All dimensions in [mm]

⁽¹⁾ J spacing of holes for fixation to formwork

⁽²⁾ E outer dimensions of E and EP – or E(QT) and EP(QT) - are identical

**A.6.5.3 LOCAL ANCHORAGES ZONE REINFORCEMENT
TYPE NC AND NC-U @ 53/64 MPa**

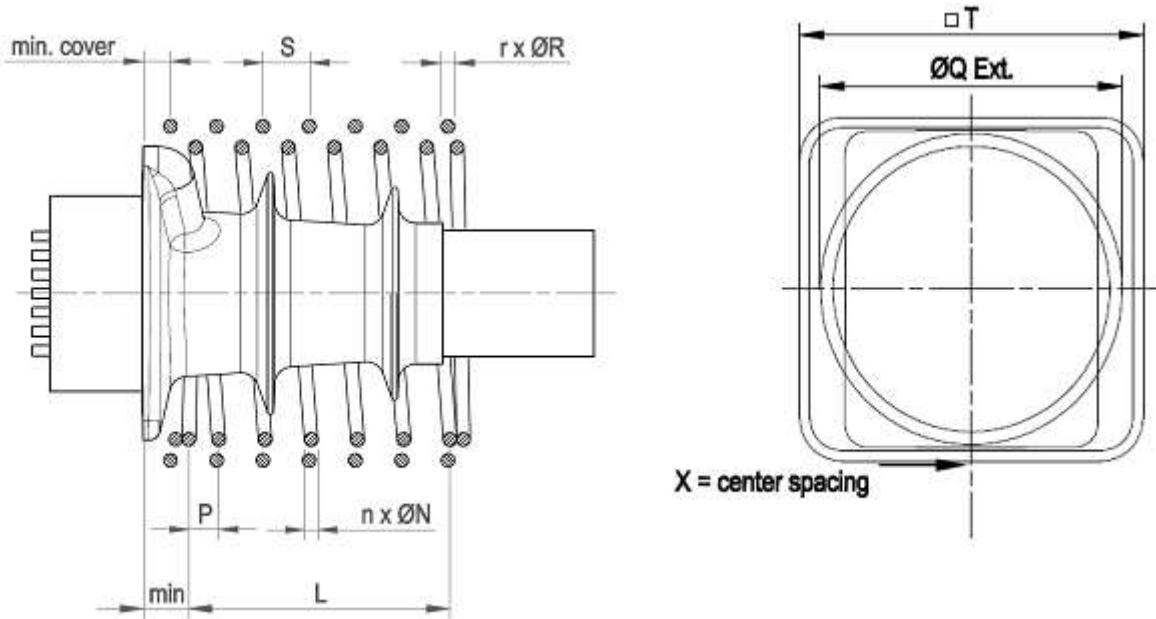

Figure 47 Local anchorage zone reinforcement type NC and NC-U @ 53/64 MPa

Reinforcement for concrete with $f_{c,min(t)} \geq 53/64 \text{ N/mm}^2$ (cylinder/cube) at time of stressing

Unit	SPIRAL REINFORCEMENT					ORTHOGONAL REINF.				X
	ØN	n ⁽¹⁾	P	ØQ	L	ØR	r ⁽²⁾	S	T	
6-55	20	11	55	580	495	18	11	80	620	650

All dimensions in [mm]. Reinforcement consists of a combination of spiral and stirrups. Other combinations with equivalent performance (to be approved by VSL) are also possible.

Reinforcement steel $f_{yk} \geq 500 \text{ N/mm}^2$.

⁽¹⁾ n Number of turns including first and last turn required for anchorage of spiral

⁽²⁾ r Number of reinforcement layers

A.6.6 ANCHORAGES TYPE H @ 28/35 MPa

A.6.6.1 LOCAL ANCHORAGE ZONE REINFORCEMENT TYPE H @ 28/35 MPa

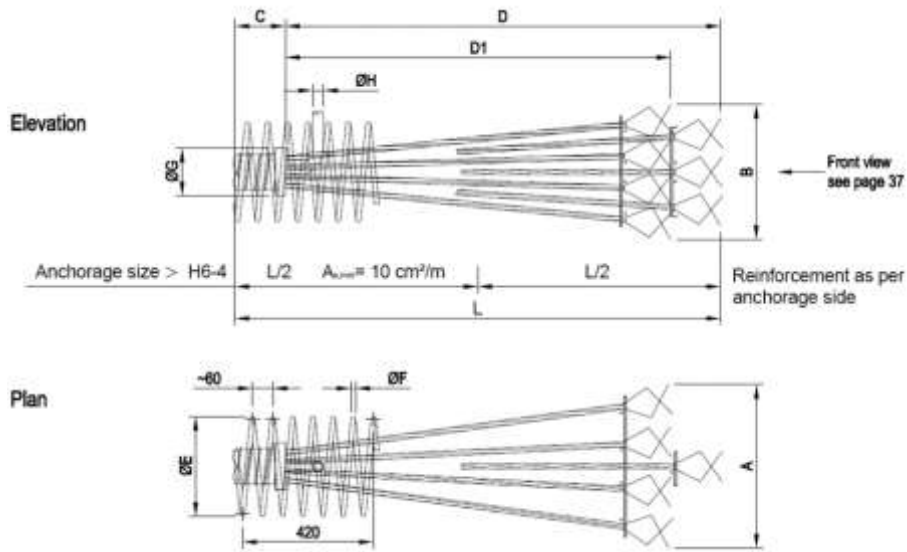

Figure 48 Anchorage and local anchorage reinforcement type H @ 28/35 MPa

Reinforcement for concrete with $f_{c,min(t)} \geq 28/35 \text{ N/mm}^2$ (cylinder/cube) when stressing

Unit	A	B	(1)	D	B	(1)	C	D1	D	ØE	ØF	ØG	ØH
	Arrangement 1			Arrangement 2									
6-1	90	90	1	-	-	-	-	-	1350	-	-	-	16/20
6-2	190	90	2	-	-	-	-	-	1350				16/20
6-3	290	90	3	-	-	-	-	-	1350	-	-	64	21/25
	210	90	2	-	-	-	-	1150	1350	-	-	64	21/25
6-4	390	90	4	210	190	4	-	-	1350	-	-	70	28/32
	310	90	2	-	-	-	155	1150	1350	-	-	70	28/32
6-5	330	90	3	-	-	-	155	-	1350	-	-	80	28/32
6-7	450	90	4	230	210	5	155	1150	1300	200	16	83	28/32
6-12	430	230	8	-	-	-	155	1150	1300	230	16	114	28/32
	-	-	-	390	330	12			-				
6-15	450	230	9	370	370	9	155	1150	1300	300	16	130	28/32
6-19	570	230	10	470	390	16	155	1150	1300	300	16	140	28/32
6-22	690	230	12	-	-	-	155	1450	1600	350	16	146	28/32
	-	-	-	490	470	20		1250	1400				
6-27	690	260	17	-	-	-	155	1500	1650	350	16	171	28/32
	-	-	-	530	510	20		1450	1600				
6-31	810	260	14	-	-	-	165	1750	1900	400	20	171	28/32
	-	-	-	570	510	20		1550	1700				
6-37	1050	370	18	-	-	-	175	2400	2550	400	20	178	28/32
	-	-	-	690	510	24		1850	2000				

Reinforcement steel $f_{yk} \geq 500 \text{ N/mm}^2$.

(1) Number of strands with length D1

A.6.6.2 ARRANGEMENT AND MINIMUM DIMENSIONS OF CONCRETE SECTIONS ANCHORAGES TYPE H @ 28/35 MPa

	Unit	Arrangement	Unit	Arrangement	Unit	Arrangement	Unit	Arrangement
Front view	6-1/6-2	1	6-3	1	6-4	1	6-4	2
Front view	6-5	1	6-7	1 / 2	6-12	1	6-12	2
Front view	6-15	1	6-15	2	6-19	1	6-19	2
Front view	6-22	1	6-22	2	6-27	1	6-27	2
Front view	6-31	1	6-31	2	6-37	1	6-37	2
<p>● Strand with length D1 ○ Strand with length D $f_{c,min(t)} \geq 28/35 \text{ N/mm}^2$ when stressing</p>								

A.6.7 COUPLERS TYPE K

A.6.7.1 CATEGORIES OF USE AND ARRANGEMENTS

Coupler type K with anchorage type E

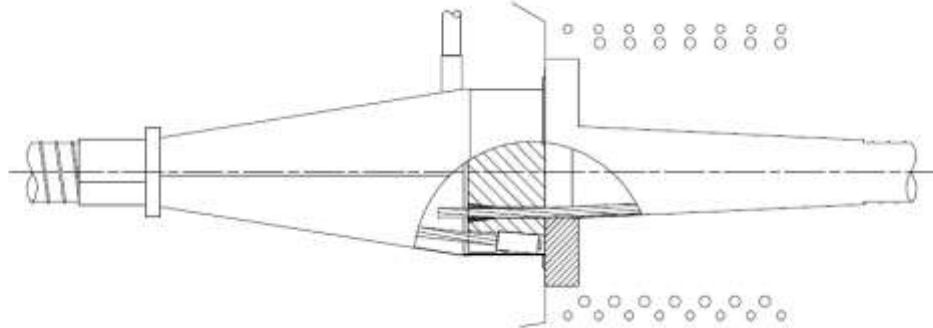

Coupler type K with anchorage type CS

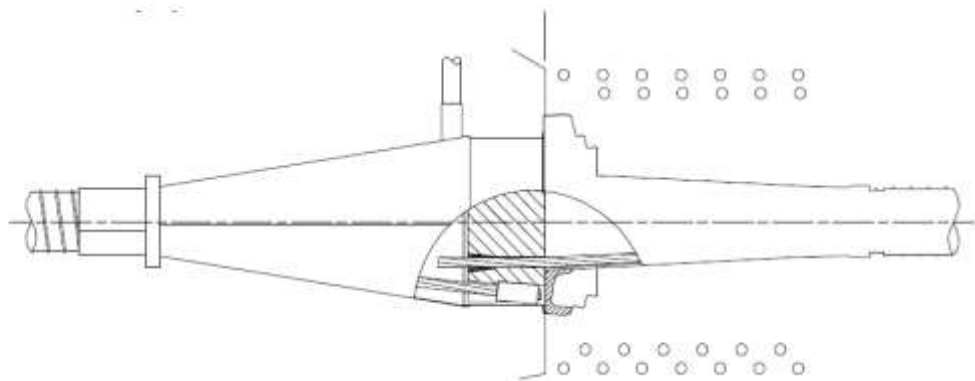

Coupler type K with anchorage type GC

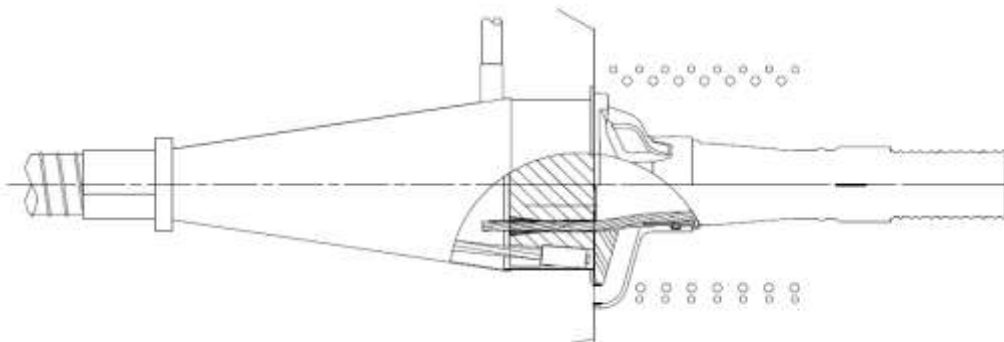

Figure 49 Categories of use arrangements couplers type K

Note: The anchorages shown above correspond to protection level 1 (PL1 as per *fib Bulletin 33*). For encapsulated (PL2) and EIT (PL3) tendons, polymeric components and isolating elements are adopted.

A.6.7.2 COUPLERS TYPE K

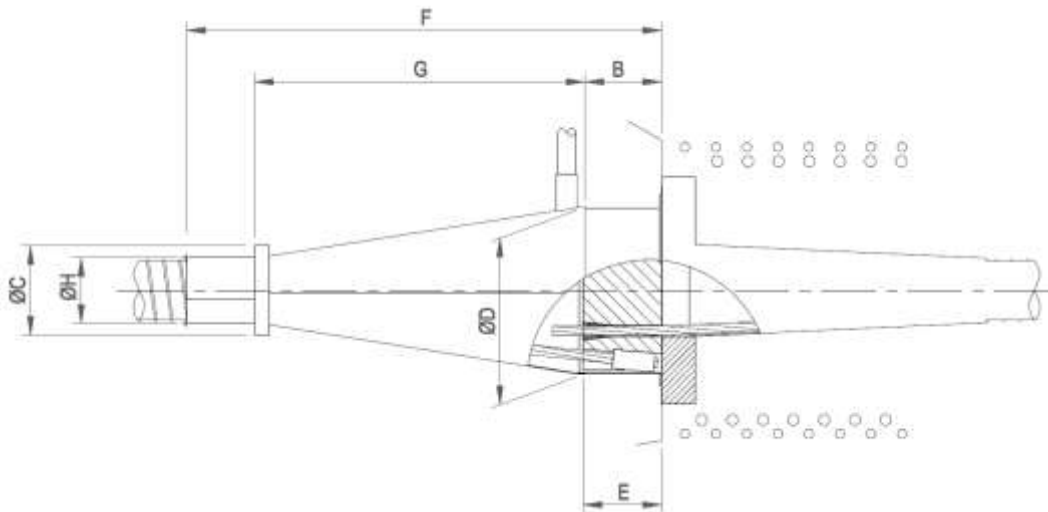

Figure 50 Couplers type K dimensions

Unit	$\varnothing C$	$\varnothing D$	B	F	G	$\varnothing H$	E
6-3	76	150	160	430	214	62	118
6-4	83	160	160	440	218	67	118
6-7	95	190	160	560	321	77	128
6-12	121	240	160	660	423	97	128
6-15	133	270	160	770	532	102	128
6-19	146	280	160	770	532	112	128
6-22	159	310	160	910	631	122	128
6-27	168	350	180	980	688	132	150
6-31	178	360	180	970	658	142	150
6-37	203	400	200	1200	868	155	168

All dimensions in [mm]

A.6.8 COUPLERS TYPE V

A.6.8.1 CATEGORIES OF USE AND ARRANGEMENTS

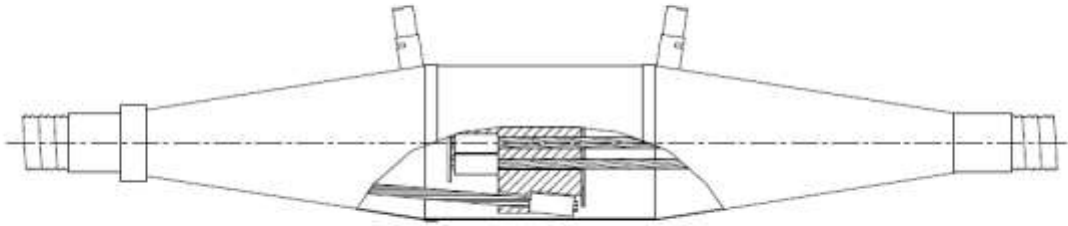

Figure 51 Category of use arrangement couplers type V

Note: The anchorages shown above correspond to protection level 1 (PL1 as per *fib Bulletin 33*). For encapsulated (PL2) and EIT (PL3) tendons, polymeric components and isolating elements are adopted.

A.6.8.2 COUPLERS TYPE

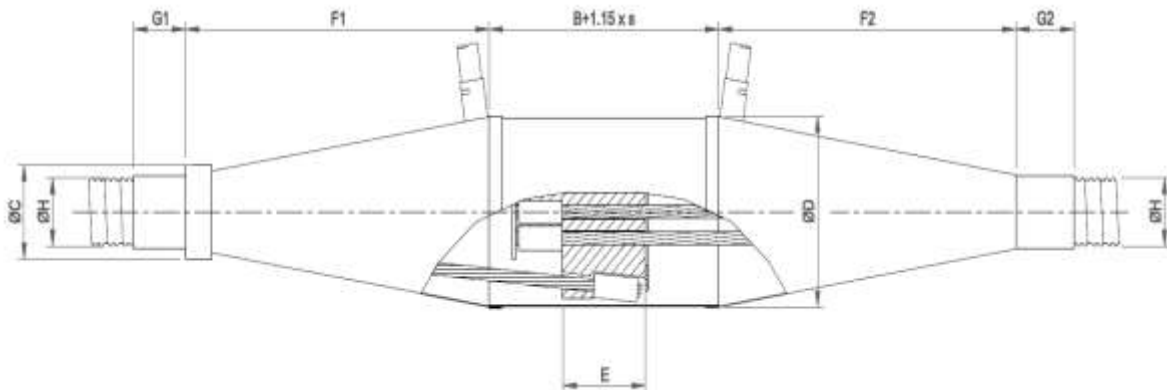

Figure 52 Couplers type V dimensions

Unit	ØC	ØD	B	F1	F2	G1	G2	ØH	E
6-3	76	150	210	210	200	60	70	60	118
6-4	83	160	220	220	210	60	70	65	118
6-7	95	190	220	320	310	80	90	75	128
6-12	121	240	220	420	410	80	90	95	128
6-15	133	270	220	530	520	80	90	100	128
6-19	146	280	220	530	520	80	90	110	128
6-22	159	310	220	630	620	120	130	120	128
6-27	168	350	240	690	670	110	130	130	150
6-31	178	360	240	660	640	130	150	140	150
6-37	203	400	260	870	850	130	150	153	168

All dimensions in [mm]

s = coupler movement due to stressing

A.6.9 BLOCK-OUT DIMENSIONS – CLEARANCE REQUIREMENTS

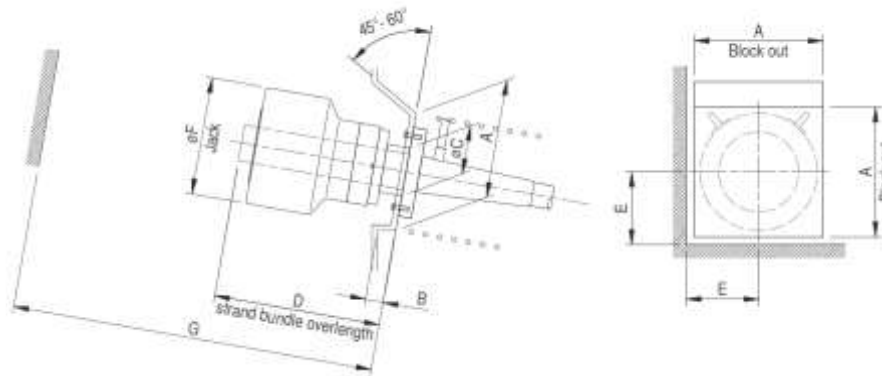

Figure 53 Block-out dimensions – Clearance requirements

Unit	Jack ZPE	A	B	ØC	D	E	ØF	G	Weight kg
6-1	ZPE-23FJ	135	140	40	300	90	116	1200	23
	ZPE-30	200			600	100	140	1350	28
6-2	ZPE-60	170	140	60	650	140	180	1100	74
6-3	ZPE-60	195	140	70	650	140	180	1100	74
6-4	ZPE-7A	220	145	80	650	200	280	1400	115
6-7	ZPE-12St2	305	150	90	670	200	310	1300	151
	ZPE-200				950	210	315	2000	308
	ZPE-185				620	180	300	1220	280
6-12	ZPE-19	370	165	125	850	250	390	1500	294
6-15	ZPE-460/31	460	175	150	700	300	485	1500	435
	ZPE-500				1050	330	550	2100	1064
6-19	ZPE-460/31	460	185	160	700	300	485	1500	435
	ZPE-500				1050	330	550	2100	1064
	ZPE-500K				1150	330	510	2000	450
6-22	ZPE-500	530	190	175	1050	330	550	2100	1064
	ZPE-580				860	280	500	1620	650
6-27	ZPE-750	595	200	195	1150	365	520	2600	1100
6-31	ZPE-750	595	210	200	1350	365	520	2600	1100
	ZPE-1000				1200	450	790	2400	2290
6-37	ZPE-1000	640	225	225	1200	450	790	2400	2290
	ZPE-1250				1250	375	620	2550	1730
	ZPE-980				950	360	650	1760	1170
6-43	ZPE-1000	680	235	250	1200	450	790	2400	2290
	ZPE-1250				1250	375	620	2700	1730
6-55	ZPE-1000	760	250	260	1200	450	790	2400	2290
	ZPE-1250				1250	375	620	2700	1730
	ZPE-1450				1010	420	770	1850	1690
6-55	ZPE-1350	760	250	260	1000 (2)	470	840	3500 (2)	3500 (2)

Notes: (1) If a deeper recess > B is required, minimum lateral clearance E applies instead of block-out dimension A
 (2) Dimensions D, G and the weight of stressing jack type ZPE 1350 depend on jack configuration.
 General Other models of jacks can be used if they are accepted by VSL. Refer to the latest revision of the VSL PT brochure or contact VSL for an updated list of equipment.
 The above dimensions depend on the post-tensioning units and the available jacks. They may be reduced if absolutely necessary. In such cases, consult the VSL Technical Centres.

A.6.10 XT-DEVIATORS – DIMENSIONS AND CONDITIONS OF USE

XT-Pad Super Compact

(Max intentional deviation 2° per pad)

XT-Pad Compact

(Max intentional deviation 3° per pad)

XT-Pad parallel

(Max intentional deviation 3° per pad)

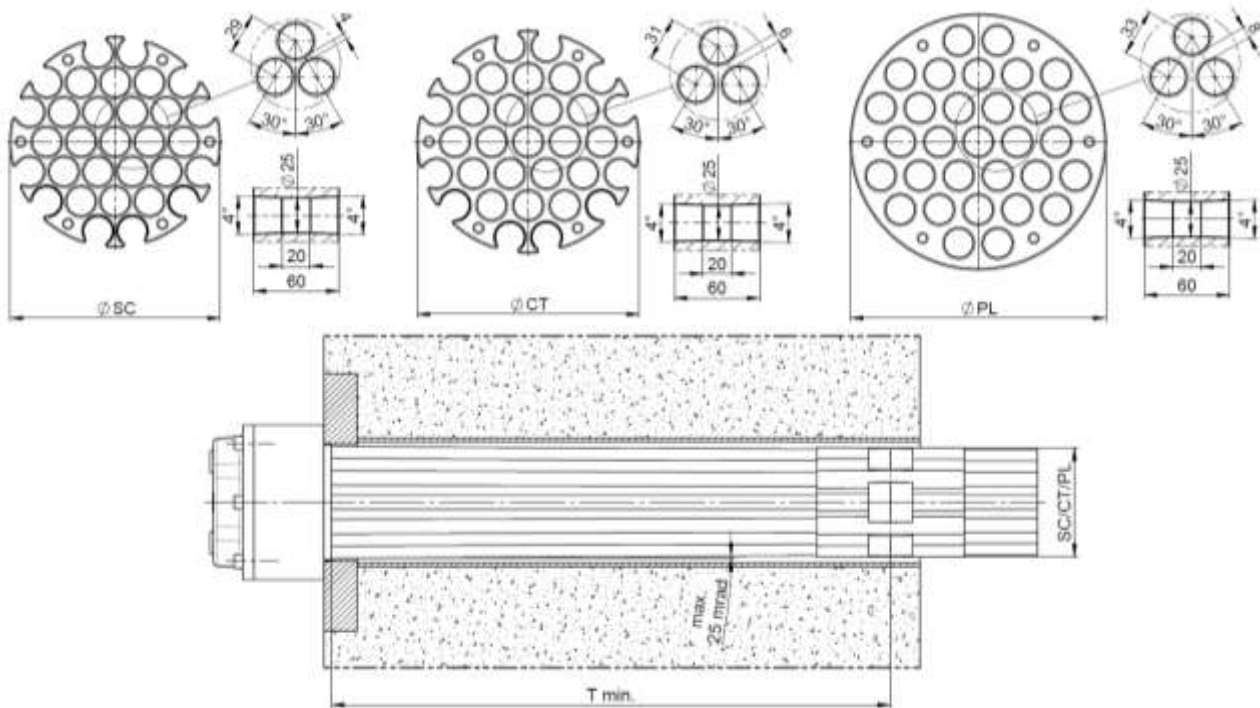

Unit	XT Super Compact		XT Compact		XT Parallel	
	ØSC	T _{min}	ØCT	T _{min}	ØPL	T _{min}
6-4	74	200	82	200	88	200
6-7	94	200	100	200	108	200
6-12	113	274	119	200	142	200
6-15	133	330	140	200	164	200
6-19	140	350	148	200	173	200
6-22	157	396	166	212	192	200
6-27	170	432	180	232	207	200
6-31	178	452	188	242	216	200

Figure 54 Dimensions and types of XT-pads

Notes: T_{min} is the minimum distance from the backside of the anchorage to the center of the (first) XT- pad, considering that the XT-pad is centered inside the recess tube. If the center of the XT-pad is offset, the distance shall ensure that the most deviated strand of the bundle is deviated less than 25 mrad (1.4°).

The thickness of the XT-pads is 60 mm for all units.

The table above shows the minimum dimensions of the components.

The total allowable intentional deviation angle per pad is 3 degrees (for the parallel and compact pad) or 2 degrees (super compact pad), including a maximum transient deviation of 1 degree.

The XT-deviators (all types) allow to accommodate an additional unintentional deviation of 0.5°.

VSL Post-Tensioning System

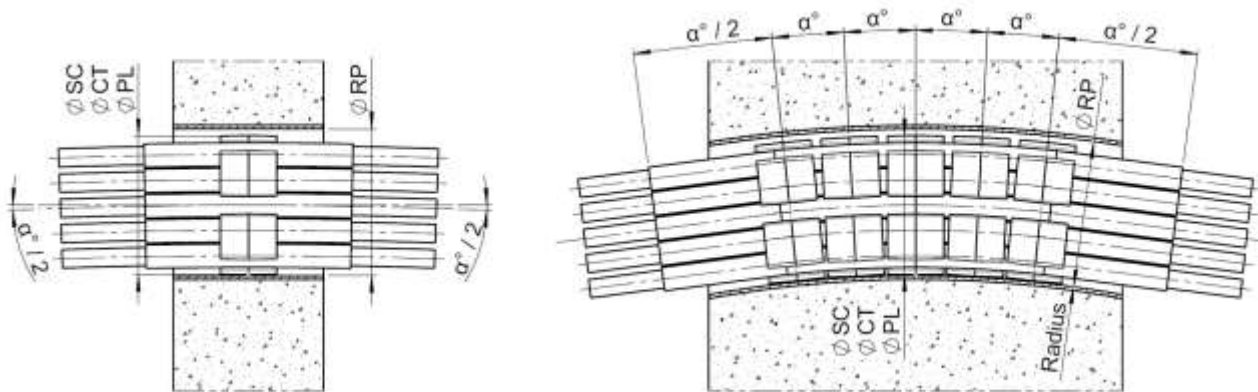

Unit	XT Super Compact					XT Compact					XT Parallel			
	ØSC	ØRP min.	ØRP max.	α°	Radius	ØCT	ØRP min.	ØRP max.	α°	Radius	ØPL	ØRP min.	α°	Radius
6-4	74	77	86	max. 2°	min. 1720	82	85	102	max. 3°	min. 1150	88	91	max. 3°	min. 1150
6-7	94	97	106			100	103	120			108	111		
6-12	113	113	125			119	122	139			142	145		
6-15	133	136	145			140	143	160			164	167		
6-19	140	143	152			148	151	168			173	176		
6-22	157	160	169			166	169	186			192	195		
6-27	170	173	182			180	183	200			207	210		
6-31	178	181	190			188	191	208			216	219		

Figure 55 Serial arrangement of VSL XT-Pad as saddle deviator

Notes: The VSL XT-pads can be assembled in series, with a maximum deviation angle of 2 degrees (in the case of super-compact XT-pads) or 3 degrees (in the case of compact or parallel XT pads) per individual XT-pad.
 The minimum radii obtained with adjacent XT-pads is 1720 mm (super-compact XTpads) or 1150 (compact or parallel XT-pads).
 Buffer tubes may run continuously through the individual XT-pads, providing bedding to sheathed strands.
 Values for internal diameter of recess tube are calculated to allow for threading or to provide adequate support to the XT-pads super-compact or compact. Bigger diameter may be used with adequate measures (contact VSL for more detail). Parallel XT-pads can be installed on flat surfaces. Alignment ropes or distancing elements (not depicted above) may be installed to maintain the geometry of the individual VSL XT-pads.

A.6.11 DUCTING

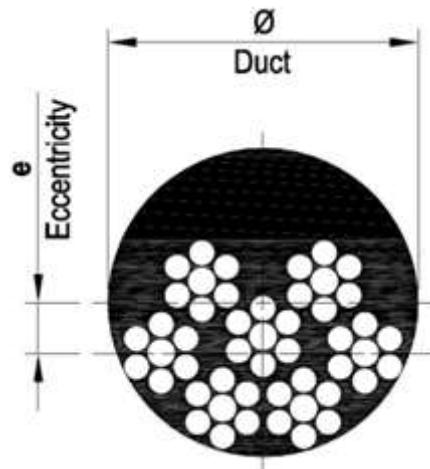

Figure 56 Ducting dimensions

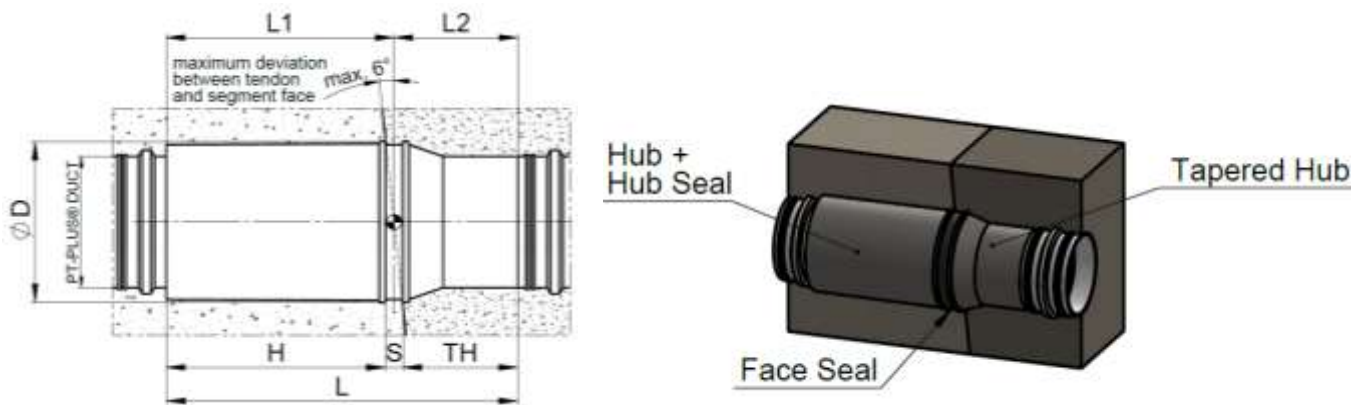

Figure 57 Segmental Couplers – PT-Plus Round Duct

PT-Plus® Duct	ØD	L	L1	L2	H	S	TH
59	φ88	242.5	155.5	87	150.5	10	82
65	φ95	273	173	100	167.5	11	94.5
76	φ106	258	173	85	167	12	79
85	φ115	273	173	100	166.5	13	93.5
100	φ130	270	184	86	177	14	79
115	φ145	284	184	100	176	16	92
130	φ160	256	173	83	164.5	17	74.5
150	φ180	284	184	100	174.5	19	90.5

All dimensions in [mm]

VSL Post-Tensioning System

Strand No	Unit	Corrugated Steel Strip Sheath (1)(5)				Duct VSL PT-PLUS (2)(5)		Smooth Steel Duct (3)(5)	Polymeric Duct (4)(5)	Polymeric Duct for Sheathed Strand (4)(5)	
		Recommended		Minimum		$\varnothing_{int} / \varnothing_{ext}$	e				
		$\varnothing_{int} / \varnothing_{ext}$	e	$\varnothing_{int} / \varnothing_{ext}$	e			$\varnothing_{ext} \times t$	$\varnothing_{ext} \times t \text{ min}$	$\varnothing_{ext} \times t \text{ min}$	
1	6-1	30/35	7	25/30	5	22/25	4	25.0 x 2.0	25 x 2.0	32 x 2.4	
2	6-2	45/50	12	40/45	9			42.4x2.0/2.5/3.0	40 x 3.0	50 x 3.7	
3	6-3	45/50	9	40/45	6			42.4x2.0/2.5/3.0	50 x 3.7		
4	6-4	50/57	10	45/50	7			48.3x2.0/2.5/3.0	50 x 3.7	75 x 5.6	
5	6-7	55/62	11	50/57	8	58/63	13	76.1 x2.0/2.5/3.0	75 x 5.6	90 x 5.4	
6		60/67	12	55/62	9	58/63	11				
7		60/67	10	55/62	7	65/70	14				
8	6-12	70/77	14	65/72	11	76/81	18	80.0 x2.0/2.5	90 x 5.4	110 x 5.3	
9		70/77	12	65/72	9						16
10		75/82	14	70/77	11						15
11		75/82	12	70/77	9						13
12		80/87	14	75/82	11						12
13	6-15	85/92	16	80/87	13	85/91	16	101.6 x3.0/4.0/5.0	110 x 5.3	125 x 6.0	
14		85/92	14	80/87	11						16
15		85/92	13	80/87	10						12
16	6-19	90/97	15	85/92	12	100/106	22	101.6 x3.0/4.0/5.0	110 x 5.3	140 x 6.7	
17		90/97	14	85/92	11						20
18		95/102	16	90/97	13						19
19		95/102	15	90/97	12						18
20	6-22	110/117	23	100/107	17	100/106	17	114.3 x3.0/4.0/5.0	125 x 6.0		
21		110/117	22	100/107	16						16
22		110/117	21	100/107	15						15
23	6-27	110/117	20	100/107	14	115/121	22	114.3 x3.0/4.0/5.0	125 x 6.0	160 x 7.7	
24		110/117	19	100/107	13						22
25		120/127	24	110/117	18						21
26		120/127	23	110/117	17						21
27		120/127	22	110/117	16						20
28	6-31	120/127	21	110/117	15	130/136	27	127.0 x3.0/4.0/5.0	140 x 6.7	160 x 7.7	
29		130/137	27	120/127	21						26
30		130/137	26	120/127	20						26
31		130/137	25	120/127	19						25
32	6-37	130/137	24	120/127	18	130/136	24	139.7 x3.0/4.0	140 x 6.7	180 x 8.6	
33		130/137	23	120/127	17						23
34		130/137	22	120/127	16						22
35		140/147	21	130/137	22						22
36		140/147	20	130/137	21						21
37		140/147	19	130/137	20						20
38	6-43	150/157	31	140/147	25	150/157	31	152.4 x3.0/4.0/5.0	160 x 7.7	200 x 9.6	
39		150/157	30	140/147	24						30
40		150/157	29	140/147	23						29
41		150/157	29	140/147	23						29
42		150/157	28	140/147	22						28
43		150/157	27	140/147	21						27
44	6-55	170/177	37	160/167	34	150/157	27	168.3 x3.0/4.0	180 x 8.6	225 x 10.8	
45		170/177	37	160/167	33						27
46		170/177	36	160/167	32						26
47		170/177	35	160/167	32						25
48		170/177	34	160/167	31						24
49		170/177	34	160/167	30						24
50		170/177	34	160/167	29						24
51		170/177	33	160/167	28						23
52		170/177	32	160/167	27						22
53		170/177	32	160/167	27						22
54		170/177	32	160/167	27						22
55		170/177	31	160/167	26						21

- (1) Exterior \varnothing of corrugations, given for indication. Actual dimensions of corrugations to be checked with supplier. Corrugated steel strip sheaths of diameters larger than 130mm follow the design of EN 523 with the same thickness. Unless otherwise mentioned, all dimensions are recommended values. Minimum values are only suited for short cables with little curvature. For other cases, contact VSL local representative.
- (2) According to standard EN 10255, EN 10216-1, EN 10217-1, EN 10219-2 and EN 10305-3.
- (3) Polypropylene (PP) or polyethylene (PE) ducts PE 80 or PE 100 according to standard EN 12201.
- (4) Actual values may vary depending on availability and project requirements. Unless otherwise noted, values are recommended dimensions for tendons with bare strands. For dimensions with sheathed protected strands, check with VSL.

Annex B TECHNICAL DATA OF THE VSL SLAB SYSTEM

B.1	DEFINITION OF THE SYSTEM	96
B.1.1	PRINCIPLE OF THE VSL SLAB SYSTEM.....	96
B.1.2	CHARACTERISTICS OF SYSTEM UNITS	97
B.1.3	ANCHORAGES	98
B.1.4	CATEGORIES OF USE, OPTIONS AND POSSIBILITIES	99
B.2	STRANDS AND DUCTS	100
B.2.1	STRANDS USED	100
B.2.2	REQUIREMENTS OF THE UNBONDED SYSTEM.....	100
B.2.3	DUCTS USED FOR THE BONDED SYSTEM	101
B.2.4	CABLE LAYOUT.....	102
B.2.5	INSTALLATION OF DUCTS AND STRANDS	104
B.2.6	PROVISIONAL PROTECTION AND LUBRICATION	104
B.2.7	CALCULATION ELEMENTS	105
B.3	ANCHORAGES	106
B.3.1	DESCRIPTION OF ANCHORAGES COMPONENTS	106
B.3.2	QUALITY ORGANIZATION	107
B.3.3	INSTALLATION OF VSL ANCHORAGES	108
B.3.4	ANCHORAGE ARRANGEMENTS.....	109
B.3.5	GEOMETRICAL AND MECHANICAL USE CONDITIONS	109
B.3.6	LOCAL ANCHORAGE ZONE REINFORCEMENT.....	112
B.4	STRESSING	112
B.4.1	STRESSING EQUIPMENT	112
B.4.2	STRESSING PROCEDURE.....	113
B.5	INJECTION AND SEALING.....	115
B.5.1	INJECTION.....	115
B.5.2	SEALING	116
B.6	SCHEMATIC DRAWING	117
B.6.1	STANDARD ANCHORAGE ELEMENTS - WEDGES	118
B.6.2	ANCHORAGES TYPE S 6-1	119
B.6.3	ANCHORAGES TYPE S 6-1 PLUS.....	122
B.6.4	ANCHORAGES TYPE S 6-1 STANDARD	125
B.6.5	SK 6-1 SL SPRING LOADED COUPLER	128
B.6.6	ANCHORAGES TYPE S 6-4	129
B.6.7	REINFORCEMENT OF ANCHORAGE ZONE - ANCHORAGE S 6-1	132
B.6.8	REINFORCEMENT OF ANCHORAGE ZONE - ANCHORAGE S 6-1 PLUS & S 6-1 STANDARD	132
B.6.9	REINFORCEMENT OF ANCHORAGE ZONE – ANCHORAGE S 6-4	134
B.6.10	STRESSING JACKS AND CLEARANCE REQUIREMENTS	135
B.6.11	DUCTING.....	137

B.1 Definition of the system

B.1.1 Principle of the VSL Slab system

The cables of the VSL Slab System is composed by a tendon (made out of one or several strands of high-strength steel) and the anchorages placed at its extremities.

In this system, the cable may be not only the unit itself, but also the assembly of several closely spaced parallel units (in general of just one strand).

The tendons can be:

- **Unbonded.** The individually greased and sheathed monostrands are placed directly in the concrete. This feature of the cables makes their protection independent from the structure. Only greased sheathed monostrands will be considered in this ETA (see [Clause B.2.1 - Strands used](#)).
- **Bonded.** The bare strands are located inside a cylindrical or flat conduit. The void thus created is filled after stressing with grout according to EN 447 or EAD 160027-00-0301 for the purpose of bonding with the structure and inhibiting corrosion.

The individual strands comply with *prEN 10138-3: Prestressing steels - Part 3: Strand*. They are 7-wire strands with nominal diameters of \varnothing 15.2 and 15.7 mm ($f_{pk} = 1\,860$ N/mm² or $f_{pk} = 1\,770$ N/mm²). As long as EN 10138 remains a prestandard, 7-wire strands in accordance with national provisions shall be used.

By changing the type and number of strands, it is possible to obtain tendons with a characteristic breaking load from 260 to 1 116 kN.

Each strand is individually stressed and locked by a wedge inside a conical anchoring hole. The wedges clamp the strand and allow to transfer the stressing force from the jack to the anchorage.

The design force defines the type and number of strands. The type of anchorage is defined by the project requirements and the category of use.

The post-tensioning cables are usually defined by the anchorages (see [Clause B.3 - Anchorages](#)), the type of strand and the length.

As an example a “*cable VSL S 6-1 Plus Y1860 S7-15.7 L= 20.0 m*” is a cable that is 20 m long, formed by 1 strand with nominal diameter 15.7 mm, $f_{pk} = 1860$ MPa, and with two VSL S6-1 Plus anchorages at its extremities.

The units included in this ETA have 1 or 4 strands. Slab units type VSLab[®] with 2, 3, 4 and 5 strands are covered by ETA 13/0978.

In some cases it is possible to replicate units of a different number of strands by laying out parallel monostrand units and adjust the prestressing force by modifying the spacing between the individual units.

B.1.2 Characteristics of system units

The system can be used with strands with lower characteristic tensile strength or diameter (i.e. with strands with $f_{pk} = 1770 \text{ N/mm}^2$ or $\varnothing 15.2$). The provisions for tendons with strands with a characteristic tensile strength $f_{pk} = 1860 \text{ N/mm}^2$ also apply to tendons with strands with $f_{pk} < 1860 \text{ N/mm}^2$.

The standard *prEN 10138-3: Prestressing steels - Part 3: Strand* gives the following nominal values for the prestressing strands composing the VSL system units:

- Elongation at maximal force: $\geq 3.5 \%$
- Relaxation at $0.70 f_{pk}$ after 1 000 hours: $\leq 2.5 \%$
- Relaxation at $0.80 f_{pk}$ after 1 000 hours: $\leq 4.5 \%$
- Fatigue behaviour ($0.70 f_{pk}$; 190 N/mm^2): $\geq 2 \times 10^6$ cycles
- Maximum D value of deflected tensile test: $\leq 28 \%$
- Modulus of elasticity E_p : $195\,000 \text{ N/mm}^2$

The actual modulus of elasticity of the strand, measured by the supplier and communicated at the time of its supply, shall be taken into account for calculation of the cable elongations. Individually sheathed and protected strands have the same mechanical properties as the bare strands.

With the strand characteristics defined in prEN 10138-3 and the values of tendon cross-sections A_p the maximum forces recommended by EN 1992-1-1 are:

$$P_{\max} = \min \{k_1 \cdot A_p \cdot f_{pk}; k_2 \cdot A_p \cdot f_{p0.1k}\}, \text{ with } k_1 = 0.8, k_2 = 0.9$$

$$P_{m0,\max} = \min \{k_7 \cdot A_p \cdot f_{pk}; k_8 \cdot A_p \cdot f_{p0.1k}\}, \text{ with } k_7 = 0.75, k_8 = 0.85$$

Where P_{\max} is the maximum force applied to a tendon and $P_{m0,\max}$ is the maximum value of the initial force immediately after load transfer to the anchorage.

In accordance with the requirements of EN 1992-1-1 temporary overstressing is permitted to a maximum force of $k_3 \cdot A_p \cdot f_{p0.1k}$, with $k_3 = 0.95$.

P_{\max} and $P_{m0,\max}$ can be increased in accordance with section 4 of EN 1992-1-1 if the actual values of the strand are $f_{p0.1k} / f_{pk} > 0.88$.

Taking $f_{p0.1k} = 0.88 f_{pk}$ the forces for the VSL PT system units are as follows:

STRAND GRADE		Y1770 S7-15.7 $f_{pk} = 1\,770 \text{ N/mm}^2$ $F_{pk} = 266 \text{ kN}; F_{p0.1k} = 234 \text{ kN}$			Y1860 S7-15.3 $f_{pk} = 1\,860 \text{ N/mm}^2$ $F_{pk} = 260 \text{ kN}; F_{p0.1k} = 229 \text{ kN}$			Y1860 S7-15.7 $f_{pk} = 1\,860 \text{ N/mm}^2$ $F_{pk} = 279 \text{ kN}; F_{p0.1k} = 246 \text{ kN}$		
		A_p mm ²	P_{\max} kN	$P_{m0,\max}$ kN	A_p mm ²	P_{\max} kN	$P_{m0,\max}$ kN	A_p mm ²	P_{\max} kN	$P_{m0,\max}$ kN
S 6-1 / H 6-1	6-1	150	210.3	198.6	140	206.2	194.8	150	221.0	208.7
H 6-2	6-2	300	420.6	397.2	280	412.5	389.6	300	441.9	417.4
H 6-3	6-3	450	630.8	595.8	420	618.7	584.3	450	662.9	626.1
S 6-4 / H 6-4	6-4	600	841.1	794.4	560	824.9	779.1	600	883.9	834.8

Note: Prestressing force applied to structure must be in accordance with national regulations

B.1.3 Anchorages

B.1.3.1 Presentation of the anchorages

The VSL Slab System anchorages are all (with the exception of the type H bonded anchorages) available for use with **unbonded** or **bonded** tendons. The anchorages may be classified as follows:

Type S 6-1, S 6-1 Standard, S 6-1 PLUS and S 6-4 active end anchorages

These active anchorages are designed to anchor the tendons at the stressing end. They are composed of an anchor head drilled with conical holes that house the permanent locking wedges. These anchorages can be used for **unbonded** and **bonded** tendons. In contrast to the VSL Multistrand system, in the slab anchorages the anchor head and the bearing plate are integrated into one single structural component (called anchor head or anchorage).

The continuity of protection between the duct and the anchor head is provided by a polymeric sleeve. In the case of S 6-1 PLUS, a polymeric coat covers the external faces of the anchorage in continuity of the polymeric sleeve.

In the unbonded case, a cap is required to encapsulate the wedges and the unsheathed length of the strand after filling with a protective product (identical or compatible with the greased and sheathed single strands).

The S 6-1, S 6-1 Standard and the S 6-1 PLUS anchorages can be used as intermediate anchorages at a construction joint where the strands run through the intermediate anchorage. The first section of the tendon is stressed. When the second section of the slab is built, the tendon is stressed at the end anchorage and the intermediate anchorage becomes obsolete but remains in place. The remaining wedge bites on the free length are acceptable. Overlapping wedge bites on the strand and angular deviation of the strand before or behind the intermediate anchorage shall however be avoided.

Type S 6-1, S 6-1 Standard, S 6-1 PLUS and S 6-4 passive end anchorages

These passive anchorages block the tendons at the passive end, where stressing is not carried out. These anchorages on the passive end are the same as on the stressing end and they can be used for **unbonded** and **bonded** tendons.

The wedges are installed inside the anchorages that remain accessible at the time of stressing for checking.

These anchorages can also be used as embedded dead end anchorages. In this case, their wedges are pre-locked into the anchorage bodies.

The protection of these dead end anchorages is identical to that of the live end anchorages.

Type SK 6-1 SL spring-loaded coupler

The movable spring loaded coupler allows to connect two extremities of strand by means of an anchorage body that houses two opposite wedges that are held in position by a spring.

Type H 6-1 to H 6-4 bonded anchorages

These anchorages can only be used for the **bonded** system. They are the same as those of the VSL Multistrand System, which has been detailed in [Annex A](#) (see [Clause A.3.1.1 – Live end / dead end anchorages](#)).

B.1.3.2 List of approved anchorages

The units of the VSL Slab System covered in this ETA are:

System	ANCHORAGE	Active or passive end			Spring loaded coupler	Bonded
	UNIT					
Unbonded	6-1	S 6-1	S6-1 PLUS	S 6-1 Standard	SK 6-1 SL	
	6-4	S 6-4				
Bonded	6-1	S 6-1	S6-1 PLUS	S 6-1 Standard	SK 6-1 SL	H 6-1
	6-2					H 6-2
	6-3					H 6-3
	6-4	S 6-4				H 6-4

Note: The anchorages of the bonded system include components to allow for injection of cementitious grout.

The strands of the VSL Slab PT System are stressed individually with the VSL stressing jacks, which are presented in [Clause B.4](#). Other models of jacks could be used if they are approved by VSL.

B.1.4 Categories of use, options and possibilities

B.1.4.1 Uses and options of VSL Slab system units

The VSL Slab System units are entirely internal to the concrete; they may be:

- **Unbonded**, i.e. with individually greased and sheathed monostrands, unbonded to the structure
- **Bonded**, i.e. with bare strands placed inside a duct and with cementitious grout, providing bonding to the structure

These units may also be:

- Replaceable provided the absence of bonding with the structure
- Encapsulated leak tight
- Electrically-insulated

ANCHORAGES USES	S 6-1	S 6-1 PLUS	S 6-1 Standard	S 6-4	SK 6-1 SL	H 6-1 to 6-4
	internal* bonded cable with metallic duct	✓	✓	✓	✓	✓
internal* bonded cable with polymeric duct	✓	✓	✓	✓	✓	✓
internal* unbonded	✓	✓	✓	✓	✓	
external* cable with cementitious filler						
external* cable with flexible filler						
tendon for use in various material as external cable (1)	✓	✓	✓			
restressable tendon (2)	✓	✓	✓	✓	✓	
exchangeable tendon (3)	✓	✓	✓	✓	✓	
encapsulated tendon (leak tight)	✓	✓		✓	✓	
electrically isolated tendon				✓		

(*) internal/external to the concrete

General The anchorages of the bonded system include components to allow for injection of cementitious grout.

- (1) The anchorage must be embedded in concrete block.
- (2) Only if they are unbonded to the structure.
- (3) The designer must check feasibility regarding geometrical tendon layout.

B.1.4.2 Possibilities of the VSL Slab system

Partial stressing or stressing in stages

Stressing can be carried out in stages. It is also possible to stress some of the individual strands to obtain a partial stressing. Once the target force has been reached, pressure in the jack is released and the wedges are clamped inside the anchor head. At the end of each stressing phase, the wedges are locked inside their cavities, transferring the load from the jack to the anchorage. The procedure is the same in the case of long tendons, where the elongation is reached after several jack strokes.

Destressing

It is possible to destress a S 6-1, S 6-1 PLUS, S 6-1 Standard or S 6-4 anchorage with special tooling provided that the required strand overlengths are available and the strands remain unbonded to the structure. The value of the overlength is given in [Clause B.6.10 – Stressing jacks and clearance requirements](#).

B.2 Strands and ducts

B.2.1 Strands used

Strands are presented in [Clause B.1.2 – Characteristics of system units](#). They shall comply with *prEN 10138-3: Prestressing steels – Part 3: Strand*. They may be Y1860S7–No. 1.1366 or Y1770S7– No. 1.1365.

Individually greased and sheathed monostrands can be used for unbonded tendons, either internal or external to concrete or other materials. They are compliant with EAD 160004-00-0301, which specifies the requirements, verification methods and acceptance criteria of both the grease and the sheathing.

B.2.2 Requirements of the unbonded system

The greased and sheathed monostrand are installed directly in contact with the concrete. Regularly-spaced supports are necessary to achieve the required geometry.

The connection of the monostrand sheathing and the anchorage body is made by a sleeve for one strand (in the case of the S 6-1, S 6-1 PLUS and S 6-1 Standard anchorages) or for 4 strands (for the S 6-4 anchorage). These connections are made of polymeric material and provide for a watertight seal with the sheathing.

B.2.3 Ducts used for the bonded system

The VSL Multistrand System can use several types of duct that are described in this section. The duct type will depend on the project requirements, the final use of the structure and the type of post-tensioning units.

The VSL Slab System is used with cylindrical ducts (for the 6-1 units) and with flat ducts (for the 6-4 units). The details are given in [Clause B.6.11 - Ducting](#).

B.2.3.1 Types and dimensions of usable ducts

Depending on the specific application and the required protection level 1, 2 or 3 (PL1 to PL3 as per *fib Bulletin 33 – Durability of post-tensioning tendons*), various types of ducts are used. From a general point of view the ducts must be able to define the specified cable profile (if they are embedded in concrete), provide leak tightness during filler injection and protect the strands against external corrosion attack (in the case of external cables). They need therefore to be mechanically resistant, display continuity in shape, ensure continuity at splices and, if required, provide electrical insulation over their entire length. They shall also provide an efficient bond to the structure (when this is required) and not cause any chemical attack to the prestressing steel.

The following table shows the type of ducts that is usually adopted for different applications:

Applications		Ducts	Metal duct	Polymeric duct
			Corrugated steel strip flat sheath	VSL PT-PLUS®
Cable inside the concrete with cementitious filler	Standard (PL1)		✓	✓
	Encapsulated (PL2)		NA	✓ ^(a)
	Electrically isolated tendons (PL3)		NA	✓ ^(a)
NOTES:				
General Protection levels (PL1, PL2 and PL3) as per <i>fib Bulletin 33-Durability of post-tensioning tendons</i>				
(^a) PL2 and PL3 tendons with VSL PT-PLUS® are bonded to the structure..				
✓ : Recommended			NA: not allowed	

The ducts of the VSL Strand System, with either cylindrical or oblong cross-section, must be large enough to allow for easy installation of the strands and adequate injection of the protective filling product.

The height of the oblong section of flat ducts is considerably less than two strand diameters in order to ensure that they remain parallel side by side, in the same position all along the tendon.

The recommended duct dimensions and the eccentricity values are given in [Clause B.6.11 - Ducting](#).

The ducts may be supplied in coils or straight segments.

B.2.3.2 Metal ducts

The tendons are most often isolated from the concrete by means of corrugated steel strip sheaths. This corresponds to a standard protection level PL1 as defined by *fib Bulletin 33*. The flat sheaths are formed from cylindrical sheaths Category 1 (normal sheaths) as per EN 523.

The connections between coils or straight segments are made by a connector (coupler). The joints are sealed by either adhesive tape or thermo-retractable sleeves.

B.2.3.3 Polymeric ducts

In the case of stringent requirements regarding the corrosion protection (PL2 and PL3 as per *fib Bulletin 33*) and the fatigue resistance of cables, VSL recommends to use the corrugated polymeric duct VSL PT-PLUS® (6-1 round / 6-4 flat, see [Clause B.6](#)). This duct is used only for internal PT inside concrete in combination with a cementitious filler. It provides perfect bond between the strands and the structure.

The VSL PT-PLUS® duct complies with EAD 160004-00-0301. The duct segments are connected by mirror welding or by connectors that provide for both a waterproofing connection and electrical isolation. Rigid half-shell supports are installed at the high points of the cable path in order to avoid damages during tendon stressing, if radius curvature is less than two times the minimum permissible radius of curvature.

For design in accordance with EN 1992 it may be assumed that tendons with PT-PLUS polymeric ducts have a 50 % longer bond length than tendons with corrugated metal ducts.

B.2.3.4 Accessories for inlets, bleed vents and outlets

Accessories for venting and if required for inlet and outlet of grout are fixed to the ducts along the cable path in order to obtain complete filling of the cables. These accessories include shells or collars fastened to the ducts and connected to tubes that are accessible from the outside. The following options are available:

Duct	Duct connection accessory	Venting accessory
Corrugated steel strip sheath	Sealed polymeric shell	Polymeric pipe
VSL PT-PLUS® duct	Couplers with grout vent	Polymeric pipe

The position of inlet, venting and outlet points along the cable profile is defined by the design.

B.2.3.5 Connection with trumpets

The anchorage body of the S6-1, S6-1 Standard and S6-1 PLUS is connected to a trumpet or sleeve that is aligned with the strand. In the case of the S 6-4, the strands are deviated by a trumpet at the transition between the duct and the S 6-4 anchor head. This trumpet is considered a part of the anchorage.

The seal between the duct and the trumpets is carried out with adhesive tape, thermo-retractable sleeves or duct accessories (e.g. a VSL PT-PLUS® coupler).

B.2.4 Cable layout

The cable layout is defined by the project.

B.2.4.1 Straight lengths behind the anchorages

For the anchorages of the VSL Slab System their trumpet length is sufficient as straight length behind the anchorage.

B.2.4.2 Radius of curvature

Unbonded system

The minimum radius of curvature r_{\min} of the greased and sheathed monostrands is:

$$r_{\min} \geq 2.50 \text{ m,}$$

Tendon sections may be curved in a U-shape at a tight radius to form a passive inaccessible end. These sections of the tendon are usually named loop anchorages (not considered to be an anchorage as per EAD 160004-00-0301). They are placed at approximately mid-length of the cable and are stressed simultaneously at both ends. In this case, the minimum radius is:

$$r_{\min} \geq 0.60 \text{ m}$$

In the case of an anchorage with several strands, the strands shall be laid out such that the radial force due to deviation of one strand does not harm the adjacent strand.

Bonded system

The minimum radius of curvature r_{\min} of the flat sheaths made out of steel strip and of the VSL PT-PLUS® flat duct (see [Clause B.6](#)) is:

- plane: $r_{\min} \geq 6.00 \text{ m}$, tendon curvature in one direction only
- elevation: $r_{\min} \geq 2.50 \text{ m}$.

For the VSL PT-PLUS® round duct 22/25, the minimum radius is:

$$r_{\min} \geq 2.50 \text{ m}$$

If national regulations exist, radius of curvature must comply with them.

B.2.4.3 Spacing of the supports and tolerances

The position of the supports under the duct is defined in the design. It is usual to install them approximately every meter for a large radius of curvature and every fifty centimetres for a small radius of curvature in order to obtain the required geometry. In the case of two-way post tensioned slabs, the design also defines the sequence of installation to avoid the risk of crossing the tendons.

The ducts and tendons are firmly fastened to their supports at a distance that prevents excessive displacements or deformations. The tolerances on cable positions in the concrete elements must comply with EN 13670.

Whenever a cable is or may be deviated in the vicinity of an edge of concrete which could lead to spalling of concrete cover, additional rebar shall be designed and installed in the structure. Special attention must be paid to outward pressure due to structural singularities, such as floor openings.

The tendons of the VSL Slab System may be installed in slabs with a thickness below 450 mm according to the "Freie Spanngliedlage" (free tendon layout) method. In this case, the maximum spacing of tendon supports is:

- 1.5 m between the tendon fixation to the top layers of reinforcement and an adjacent anchorage
- 3.0 m between the tendon fixation to the bottom layers of reinforcement and an adjacent anchorage or the tendon fixation to the top layer of reinforcement.

At the low points and high points of the tendon profile, the tendons have to be attached to the top and bottom layers of reinforcement, respectively, on at least two locations at a distance of 0.3 m to

1.0 m. The fixation shall ensure a tight fit without damaging the tendon sheathing. The reinforcement layers have to be installed in accordance with the relevant standards.

B.2.4.4 Strand cut length

The total strand length shall be defined by adding the length of the post-tensioning tendon between the anchorages to the thickness of the anchor heads and the stressing overlength (crossing the stressing jack). These overlengths are given in [Clause B.6.10 – Stressing jacks and clearance requirements](#).

B.2.5 Installation of ducts and strands

Depending on the conditions of the project, one of the following solutions is usually adopted:

Unbonded system

- Monostrands cut at length off the structure (eventually with the anchorages installed at their extremities) and then delivered to the worksite for installation in the structure
- Installation of individual monostrands on site before concreting

Bonded system

- Cables (both strands and ducts) fabricated off structure and then delivered to the worksite as one unit for installation in the structure
- Strand bundles fabricated off the structure and then pulled into the ducts, which have been installed in the structure, before or after concreting inside the ducts
- Pushing of individual strands through the ducts, which have been installed in the structure, before or after concreting

B.2.6 Provisional protection and lubrication

In the **bonded** system, the oiling or greasing of strands is carried out with non-dangerous substances in order to:

- Provide provisional protection against corrosion from the time of leaving the plant until permanent protection has been achieved (grouting of the cable)
- Lubricate and diminish the friction loss during stressing

With this same objective, other products may be used to reduce friction, provided that they are non-dangerous, can be easily applied and remain inert in the presence of permanent protection (and the eventual rigid bond to the structure).

For bonded post tensioning the only products that can be used are those that do not have to be removed prior to grouting.

In addition these products shall comply with the regulations of the place of use.

B.2.7 Calculation elements

B.2.7.1 Friction losses

The friction between strands and ducts, which occurs during stressing, reduces the effective post tensioning force in the strands along the cable path. The force, according to EN 1992-1-1, is expressed by the formula:

$$P_{m0}(x) = P_{m0}(0) e^{-\mu (\theta + k x)}$$

Where

- $P_{m0}(x)$ post tensioning force at a distance x of the stressing end at the time of stressing
- $P_{m0}(0)$ post tensioning force of the cable at the stressing end (with $x=0$) at the time of stressing after friction losses of the active anchorage, also called design of stressing force (specified by the designer)
- μ friction coefficient between the strands and the duct
- θ cumulated angular deviations of the cable over the distance x
- k wobble coefficient, unintentional angular displacement for internal tendons (per unit length)

It is recommended to adopt the following numerical values for the parameters μ and k given in EN 1992-1-1:

Application	μ (rad ⁻¹) (1)		k (rad/m)	
	Range	Recommended value	Range	Recommended value
Individually greased and sheathed monostrand	0.04-0.07	0.05	0.004-0.006	0.005
Cable with corrugated steel strip sheath	0.16-0.22	0.18	0.004-0.008	0.005
Cable with VSL PT-PLUS® duct	0.10-0.15	0.12	0.004-0.010	0.005

(1) The interval limit values encompass both lubricated and non-lubricated strands.

B.2.7.2 Basis for evaluating elongations

See [Clause A.2.6.2 – Basis for evaluating elongations](#).

Due to the limited clearance inside the duct, effect of strand slack may be neglected.

Note : friction losses at anchorages are given in [Clause B.4.2.1 - Force measurements](#).

B.2.7.3 Active anchorage settings

The value of the wedge draw-in is:

- 6 mm, which remains constant for all anchorages and wedges if they are installed without activation of the seating ram of the stressing jack (see [Clause B.4.1.1 – Stressing jacks](#)).
- 5 mm, which remains constant for all anchorages and wedges if they are installed with activation of the seating ram of the stressing jack (see [Clause B.4.1.1 – Stressing jacks](#)).

The VSL Slab System anchorages do not allow for any adjustment with shim.

B.3 Anchorages

B.3.1 Description of anchorages components

Live end (active) and dead end (passive) anchorages of the VSL Slab System comprise:

B.3.1.1 Live end / dead end anchorages

For these anchorages, the anchor head and the plate are combined to form a single part, commonly called the anchorage body.

The anchorages of the VSL Slab System covered by this ETA are of the following types:

S 6-1 anchorage

The anchorage body is cast in spheroidal graphite cast iron in accordance with Standard EN 1563. The conically-shaped hole is the subject of a rigorous control.

The polymeric sleeve is tightly connected to the anchorage body. In the **unbonded** case, the end cap is made of polymeric or metal material. In the **bonded** case, a temporary or permanent cap provides for a waterproof seal in order to perform the grouting.

S 6-1 PLUS and S 6-1 Standard anchorages

The anchorage body is cast in spheroidal graphite cast iron in accordance with Standard EN 1563. The conically-shaped hole is subject of a rigorous control.

The cast part of both anchorages is identical. The S 6-1 Plus is covered with an external polymeric coating to isolate the metallic anchorage body from concrete.

The polymeric sleeve is securely fastened to the exit of the anchorage body. In the **unbonded** case, the end cap is made of polymeric material. In the **bonded** case, a temporary or permanent cap provides for a waterproof seal in order to perform the grouting.

SK 6-1 SL

The SK 6-1 SL couplers are intended to connect two consecutive strands. They are made out of four components: the coupler body (fabricated in cast iron according to standard ASTM A 897 M or EN 1564), two wedges type W6ML and one retaining spring.

The couplers shall be placed inside housings (see [Clause B.6.5 - SK 6-1 SL Spring loaded coupler](#)). These housings are polymeric or steel ducts with internal diameter large enough to admit the couplers and long enough to allow the free displacement of the coupler during stressing operations. Connections between housings and standard tendon ducts (or unbonded strands) shall be adequately sealed. In case of unbonded tendons, the spaces between couplers and housings shall be filled with grease.

S 6-4 anchorage

The anchorage body is cast in spheroidal graphite cast iron in accordance with Standard EN 1563. The four conically-shaped holes are rigorously controlled.

The polymeric sleeve of this anchorage is inserted into the concrete and houses the simply-supported anchorage body.

In the **unbonded** case, a permanent cap filled with grease protects the end anchorage. In the **bonded** case, a provisional or permanent cap provides a waterproof seal in order to perform the grouting.

Wedges

The wedges are machined, threaded, cut in two pieces and finally heat treated. The following types of wedges are available:

- **W6N** and **W6S**. They are made out of alloyed steel for cementation according to Standard EN ISO 683-3 or GB/T 3077 and GB/T 5216 and they can be used with anchorages S 6-1, S 6-1 PLUS, S 6-1 Standard and S 6-4. They are used with either 0.6" or 15.2 strands (type W6N) or 0.6"S or 15.7 strands (type W6S). To be able to differentiate visually between the W6N (normal wedges) and the W6S wedges (super wedges), the S wedges have a groove on the front face.
- **W6M**. They are made out of alloyed steel for cementation according to standard EN ISO 683-4. They can be used on anchorages S 6-1 PLUS and S 6-1 Standard with 0.6" or T15.2 strands (type Y1860S7 or Y1770S7).
- **W6ML**. They are made out of alloyed steel for cementation according to standard EN ISO 683-4. They can be used on couplers SK 6-1 SL only with 0.6" or T15.2 strands (type Y1860S7 or Y1770S7). They are fabricated with clip and can only be used with spring-loaded couplers.

All wedges are all submitted to rigorous controls.

B.3.1.2 Delivery to site and sequence of operations

Unbonded system

In the usual case (internal post-tensioning of a new structure) the sequence of operations is:

1. Delivery of the S 6-1, S 6-1 PLUS, S 6-1 Standard anchorages or the S 6-4 trumpets, delivery of the monostrands and installation accessories and placement in the passive reinforcement. These anchorage components are fixed to the formwork. The anchorage components are delivered tagged, packaged and protected.
2. Delivery of the wedges (and if applicable the S 6-4 anchorages), concreting, installation of the S 6-4 anchorages and wedges, stressing, cutting of the strand overlengths and permanent protection of the anchorages. These anchorage components are delivered identified, packaged and protected.

Bonded system

In the bonded system, the installation of strand takes place before concreting and the sequence of operations is:

1. Delivery of the S 6-1, S 6-1 PLUS, S 6-1 Standard anchorages or the S 6-4 trumpets, ducts, accessories for placement within the passive reinforcement and strands. These anchorage parts are fastened to the formwork. The anchorage units arrive to the jobsite with adequate identification, packaging and protection.
2. Delivery of the wedges (and if applicable the S 6-4 anchorage body), concreting, installation of S6-4 anchorages and wedges, stressing, cutting of the overlengths, installation of temporary or permanent protection caps and injection of the permanent cable protection. These anchorage components arrive to the jobsite with adequate identification, packaging and protection.

The complete couplers SK 6-1 SL (coupler body, W6ML wedges and spring) are assembled prior to their delivery to the jobsite. They are delivered when strands have to be installed (before concreting) with proper identification, packaging and protection.

B.3.2 Quality organization

The fabrication of the anchorage components of the VSL Multistrand System is conducted in compliance with the specifications, production and control procedures laid out in the present ETA and associated documents.

The Factory Production Control implemented by the Component Manufacturers and the quality organization of the PT Specialist Company serve to ensure the traceability of the components until they are delivered and installed on the jobsite.

B.3.3 Installation of VSL anchorages

The installation of the VSL anchorages is done as described below. It shall be assigned to competent staff members within the PT Specialist Company or to well-trained PT Supervisors.

B.3.3.1 Type S 6-1, S 6-1 PLUS, S 6-1 Standard and S 6-4 active end anchorages

The S 6-1, S 6-1 PLUS or S-1 Standard anchorage bodies and the S 6-4 trumpets are attached to the formwork and connected to the monostrands or ducts, which have been installed in the structure. For detail of connections of anchorages with ducts refer to [Clause B.2.2 – Requirements of the unbonded system](#) and [Clause B.2.3 – Ducts used for the bonded system](#).

The S 6-4 anchor head is installed inside the trumpet which was placed before concrete pouring. The wedges (and the S 6-4 anchor heads) are positioned only shortly before stressing in order to avoid damages of these components.

For force losses in the anchorages during stressing, see [Clause B.4.2.1 - Force measurements](#).

B.3.3.2 Type S 6-1, S 6-1 PLUS, S 6-1 Standard and S 6-4 passive end anchorages

The wedges are installed inside the anchorages that remain accessible at the time of stressing for checking.

These anchorages can also be used as embedded dead end anchorages. In this case, their wedges are pre-locked into the anchorage bodies

B.3.3.3 TYPE SK 6-1 SL intermediate couplers

In both the **bonded and unbonded** systems, the intermediate couplers SK 6-1 SL anchorages are assembled on the strands. It is important to check that the strand is correctly positioned inside the wedge (usually by marking the extremity of the strand) and verify that it is perfectly locked by the wedge. Special attention should be paid to the position of the coupler that should be free to move during the stressing operation.

B.3.3.4 Type H 6-1 to H6-4 bonded anchorages

These fixed anchorages are only used for the **bonded** system. They are strictly identical to those of the multistrand system described in [Clause A.3.1.1 – Live end / dead end anchorages](#).

B.3.4 Anchorage arrangements

The type of anchorages and the possible categories of use (see [Clause B.1.4.1 – Uses and options of VSL Slab system units](#)) are as follows:

Anchorage	Component	Uses					
		internal bonded cable with metal duct	internal bonded cable with polymeric duct	internal unbonded	exchangeable tendon (2)	encapsulated tendon (leak tight, PL2)	electrically isolated tendon (PL3) (1) (3)
S 6-1	Anchorage body	S 6-1					n/a
	Trumpet	T connection S6-1	Sleeve S 6-1		T-connection / Sleeve S 6-1		n/a
	Cap	Closure plug S 6-1					n/a
S 6-1 Standard	Anchorage body	S 6-1					n/a
	Trumpet	T connection S 6-1 Standard	Sleeve S 6-1 Standard unbonded				n/a
	Cap	-					n/a
S 6-1 PLUS	Anchorage body	S 6-1 PLUS					n/a
	Trumpet	T connection S6-1 PLUS	Sleeve S6-1 PLUS unbonded		T-connection / Sleeve S 6-1 PLUS		n/a
	Cap	Plug – Capot S 6-1 PLUS					n/a
S 6-4	Anchorage body	S 6-4					
	Trumpet	Trumpet S 6-4					
	Cap	Grout cap S 6-4					
SK 6-1 SL		SK 6-1 SL					n/a

Notes:

- General: The anchorages of the bonded system include components to allow for injection of cementitious grout.
 (1): Electrical isolation provided by a polymeric trumpet (anchor body)
 (2): Tendon will be exchangeable only if it is not grouted
 (3): PL3 is not achievable with monostrand anchorages

B.3.5 Geometrical and mechanical use conditions

B.3.5.1 Clearance behind anchorages

It is necessary to respect a clearance behind the anchorages in order to be able to install the stressing jacks. The dimensions are given in [Clause B.6.10 – Stressing jacks and clearance requirements](#).

These dimensions have to be increased in case of use of destressing or overstressing equipment. Check with VSL for more details.

B.3.5.2 Concrete strength, cover and anchorage spacing

The post-tensioning forces are transferred to the structures in the anchorage zones. The introduction of these forces to the concrete structure has the following implications:

- A minimum distance has to be respected between adjacent anchorages (distance centre to centre) and from an anchorage to the edge of the structure. These distances are given in the table below in this clause for the different types of anchorages and units.
- A local zone reinforcement (LZR) has to be installed below or around the anchorages to primarily confine the concrete in this zone. This LZR, which is an integral part of the anchorage, is a function of the concrete strength at the time of stressing, the breaking load of the cable, the tensile strength of the passive steel and the type of anchorage used. See [Clause B.3.6](#) for more details.
- The concrete in the vicinity of the plates be well compacted and vibrated and achieve the required minimum strength at the time of stressing.
- A general distribution zone behind the anchorages, called secondary prism, must be designed and detailed by the engineer of record to ensure that the post tensioning forces introduced into the structure at the anchorages can be distributed over the full cross sectional depth of the structure without overloading the concrete and the passive steel according to applicable design rules.

The maximum values for the force applied to the tendon (P_{max}) and the maximum value after load transfer to the anchorage ($P_{m0,max}$) are given in [Clause B.1.2 - Characteristics of system units](#).

The dimensions and reinforcement of the local anchorage zone has been defined according to EAD 160004-00-0301.

The test specimens are concrete prisms tested in axial compression with a concrete cross section $A_c = a \cdot b$:

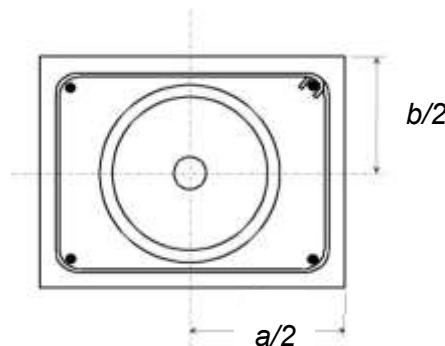

$a/2$ and $b/2$ are the distances between the anchorage axis and the edge of the test specimen.

These reference dimensions a and b allow to obtain the minimum anchorage centre spacing in the structure in the x - and y - directions (x and y), such that:

$$A_c = x \cdot y \geq a \cdot b$$

The actual **spacing/centre distance** shall comply with:

$$x \geq 0.85 a$$

$$y \geq 0.85 b$$

Where a, b: side lengths of test specimen
 x, y: minimum specified centre spacing of the particular tendon in the structure, whichever is smaller; $x \leq y$

The values of X_{\min} and Y_{\min} in both direction are given in the tables below. As explained above, it is possible to reduce the value in one of the directions (up to 85 %) if the product $x y \geq a b$. This adaptation shall comply with the applicable design rules (see [Clause B.3.6](#) for more details).

Edge distances in the structure are calculated with centre spacing in x- and y-direction by:

$$e_x = \frac{x}{2} - 10 \text{ mm} + c$$

$$e_y = \frac{y}{2} - 10 \text{ mm} + c$$

Where^o e_x, e_y : Edge distance in x- in y-direction respectively
 c: Concrete cover of reinforcement in the structure as required in the place of use

Note: 10 mm is the concrete cover of the test specimens (except for H anchorage block, where the concrete cover is 25 mm).

The local zones of adjacent anchorages should not overlap. In addition, they should remain inside the concrete.

The following table gives an overview of the different anchorages and minimum concrete strengths at time of stressing (cylinder/cube strength) for which anchorage spacing and local anchorage zone reinforcement are detailed in the data sheets of [Clause B.6](#) for the different VSL Slab systems ([S 6-1](#), [S 6-1 PLUS / S 6-1 Standard](#) and [S 6-4](#)).

$f_{c,\min(t)} \text{ (5)} \geq$	16/20 N/mm ² (3)								20/25 N/mm ² (4)			
Anchorage	S 6-1		S 6-1 PLUS		S 6-1 Standard		S 6-4		S 6-1 PLUS		S 6-1 Standard	
$u \text{ mm (1)}$ u'	105	75	122	94	117	89	280	115	117	89	117	89
$a \text{ mm (2)}$ b	180	120	180	140	180	140	400	220	170	140	170	140
X_{\min} Y_{\min} mm (6)	155	100	155	120	155	120	340	185	150	120	150	120

- (1) Sizes of anchor plate / anchorage body
- (2) Sizes of test block
- (3) With strand Y1860 S7 \varnothing 15.7 - T15.7 or 6S with $f_{pk} = 1860 \text{ N/mm}^2$, $F_{pk} = 279 \text{ kN}$ and $F_{p0.1k} = 246 \text{ kN}$ or below ($f_{pk} = 1770 \text{ N/mm}^2$)
- (4) With strand Y1860 S7 \varnothing 15.2 - T15.2 or 6 with $f_{pk} = 1860 \text{ N/mm}^2$, $F_{pk} = 260 \text{ kN}$ and $F_{p0.1k} = 229 \text{ kN}$ or below ($f_{pk} = 1770 \text{ N/mm}^2$)
- (5) Concrete strength expressed in cylinder/cube values
- (6) In case of adopting X_{\min} , the value of y will be such that $X_{\min} y \geq a b$
 The same applies to Y_{\min} (with x such that $x Y_{\min} \geq a b$)

$f_{c,min}(t)$ is the minimum concrete strength required at the time of stressing to the maximum possible stressing force P_{max} (see [Clause B.1.2 – Characteristics of system units](#) for more details). On site, the mean strength of concrete prisms / cubes tested shall be equal or bigger than the specified $f_{c,min}(t)$ at the time of stressing (i.e. 16/20 N/mm² or 20/24 N/mm²).

It remains possible however to partially tension the tendon in accordance with EN 1992 1-1 (Clause 5.10.2.2, point 4): *“If prestress in an individual tendon is applied in steps, the required concrete strength may be reduced. The minimum strength $f_{cm}(t)$ at the time t should be k_4 [%] of the required concrete strength for full prestressing given in the European Technical Approval. Between the minimum strength and the required concrete strength for full prestressing, the prestress may be interpolated between k_5 [%] and 100 % of the full prestressing.*

Note: The values of k_4 and k_5 for use in a country may be found in its National Annex. The recommended value for k_4 is 50 and for k_5 is 30.”

For example, in the case of stressing to 50 % of the maximum value at the anchorage for example, the characteristic strength f_{cm0} may be reduced to approximately 2/3 of the value indicated above.

For type H anchorages, concrete strength within the anchorage zone during stressing must be higher than $f_{c,min}(t)$, that is, higher than 28/35 N/mm² (see [Clause A.3.5 – Geometrical and mechanical use conditions](#)).

B.3.6 Local anchorage zone reinforcement

As mentioned previously, a local anchorage zone reinforcement must be used as specified in [Clause B.6](#). In accordance with EAD 160004-00-0301, this assumes the presence of additional general reinforcement of 50 kg/m³ in the structure.

In all cases, the designer shall define the reinforcement of the general anchorage zone in accordance with the applicable design rules.

The local zone reinforcement specified in this ETA and confirmed in the load transfer tests, may be modified for a specific project if required. In that case, it shall comply with national design codes and be approved by the local authority and the ETA holder to provide equivalent performance.

The contractor responsible for concreting must ensure that the density and configuration of the reinforcement allows for adequate concreting.

B.4 Stressing

B.4.1 Stressing equipment

The VSL equipment used for cable stressing is composed of stressing jacks, hydraulic pumps and measurement instruments.

B.4.1.1 Stressing jacks

The strands are individually stressed by the VSL stressing jacks. Two types of jacks are available:

- Double acting front-gripping jack, with one hollow piston
- Twin ram double acting jack, with two parallel pistons on both sides of the strand. This configuration allows to stress intermediate anchorages.

This equipment enables stressing the strand in one or several stages and then, if needed, to de-stress the strand. Their characteristics are shown on the table below.

Designation	DKP 6	Twin 25 T	ZPE 23 FJ	Alevin A 7-24
Type	2 // pistons	2 // pistons	1 hollow piston	1 hollow piston
Cross section (mm ²)	240 x 165	252 x 164	∅ 116	∅ 108
Length (mm)	615	549	790	834
Weight (kg)	30	30	23	24
Stroke (mm)	200	190	200	200
Ram area (mm ²)	4 926	5 655	4 710	4 008
Maximum pressure (bar)	467	442	488	599
Maximum force (kN)	230	250	230	240
Presence of seating ram?	No	Yes	Yes	Yes

Other models of jacks could be used if they are approved by VSL.

The drawing in [Clause B.6.10 – Stressing jacks and clearance requirements](#) indicates the clearances to be introduced around the anchorages at the ends of the post-tensioned structures in order to facilitate installation.

B.4.1.2 Hydraulic pumps

The jacks are connected to the VSL hydraulic pumps that have been designed for normal stressing speeds and contain the necessary safety elements.

B.4.1.3 Measurement instruments

Force and elongation are controlled with precision during the stressing operation by the measurement instruments.

B.4.2 Stressing procedure

Before stressing, the following must be checked:

- The safety rules and recommendations are known and they are applied.
- The target values of force and elongations are correctly defined. The PT supervisor shall know the tolerances and shall take into account the necessary adjustments to these values.
- The PT supervisor knows the procedure to be adopted in case the values are outside of the tolerance (or for any other unanticipated incident).
- The sequence of stressing is correctly specified.
- The stressing equipment (including measurement instruments) complies with the guidelines of this ETA;
- The structure is able to support the post-tensioning loads and the concrete has achieved the required minimum strength in the local zone.
- The overlengths of the strands for stressing are in good conditions.

It is forbidden to remain behind the jack or within its immediate vicinity during stressing. The same precautions must be taken for the area at the back of the dead-end exposed anchor head.

One of the key characteristics of the VSL anchorages is its wedge-locking system. The wedges remain in constant contact with the strands during stressing and the load is automatically transferred from the jack to the anchor head when the pressure is released in the jack. With some jacks, the wedges may be actively set in order to reduce the wedge draw-in (see [Clause B.2.7.3 – Active anchorage settings](#)).

B.4.2.1 Force measurements

The jacking force (or the pressure in the jack) is usually the target value, since it can be measured directly and it is directly proportional to the force along the cable in the structure. The pressure in the jack chamber is indicated by the manometers that are regularly recalibrated and are usually Class 1 (accuracy 1 % on the whole range). For the usual maximum pressure of 600 bar, the maximum admissible deviation is 6 bar.

In order to calculate the stressing force applied to the structure (and specified by the design engineer), the manometric force (obtained by multiplying the pressure reading by the pressure area) has to be corrected with the losses inside the jack and the losses due to friction of the strands in the anchorage.

The values of the losses inside the jack are measured during their calibrations and have the following values:

- DKP 6 jack and Twin jack 25 T: 3.5 %
- ZPE 23 FJ jack and Alevin A7-24 jack: 1.5 %

The losses k_a in the active anchorages have the following values:

- S 6-1, S 6-1 Standard and S 6-1 PLUS 0-1 %.
- S 6-4 0 % to 1 % for the two central strands
2 % for the two outside strands

B.4.2.2 Elongation measurements

The actual cable elongation provides information on cable behaviour during stressing and gives an indication whether the targeted force diagram along the cable in the structure has been achieved.

The values of elongations are measured directly on the strands or the stressing jack. They are recorded for the different stressing stages on the stressing record data sheets. For single strand round ducts and flat ducts, the losses due to slack may usually be neglected.

The values are compared to the theoretical elongation values, which are calculated as indicated in [Clause B.2.7.2 – Basis for evaluating elongations](#).

B.5 Injection and sealing

B.5.1 Injection

B.5.1.1 Unbonded system

The monostrand (individually greased and sheathed), protected from the factory by grease, does not need any special additional protection.

After stressing and cutting the strand overlength, the anchorages S 6-1, S 6-1 PLUS, S 6-1 Standard and S 6-4 are filled with grease (identical or compatible with that of the monostrand in compliance with EAD 160027-00-0301). A protection cap covers then the wedges and the unsheathed length.

B.5.1.2 Bonded system

General information

The type of injection products is defined by the project. The products shall comply with the local regulations and cannot be a threat to the hygiene, health and the environment.

Injection products

When the strands have to be bonded to the structure, a product with a hydraulic cement base is used as filler. These products, which make use of performance enhancing admixtures to achieve both minimum sedimentation & and segregation but have still sufficient followability to fill the cables, have to be a cement grout complying with EN 447 or more stringent requirements if prescribed by the project. In some regions of the EU unfavourable climatic conditions or other conditions impose the application of special grouts according to EAD 160027-00-0301.

In order to be able to completely fill a cable with a cementitious filler it is mandatory to seal all exposed anchor heads with either a temporary or permanent grout cap .

Concreting the block out is only strictly necessary when using temporary grouting caps (whether recycled or not). Should the permanent grouting cap be left apparent, the metallic parts must be protected against corrosion (see [Clause B.3.1 – Description of anchorage components](#)).

Injection equipment

The injection equipment is adapted to the products to be injected.

For the cement-based grouts, the VSL injection equipment is composed for the most part of mixers and pumps integrated into a single device that enables preparing the grout and performing the injection. This equipment makes it possible to dose the grout components precisely and to obtain a perfectly-homogeneous mix. The pump is designed for continuous injection with an adequate debit.

For all cases, use of either temporary or permanent grout caps equipped with venting ports to seal the anchorages until the grout hardens is mandatory.

Injection procedures

Before grouting, the following must be checked:

- The injection product must comply with the requirements of this ETA and of EAD 160027-00-0301.
- The suitability of the proposed product for the specific project has been verified by 'Suitability testing' using the equipment as allocated for the project and the product constituents from the same source as supplied for the project.
- The full tendon (free length and anchorages) is grout leak tight.
- The temperature of the air and of the structure are in accordance with the conditions of use of the injection product.
- Enough transparent tubes are available for conducting the daily wick induced test.

The leak tightness of the cable has to be verified prior to start with the injection. It is either checked by air pressure testing or by vacuum testing. Use of water to clear the cables from debris and/or checking the leak tightness with water is prohibited.

During the injection the PT crew must check at all outlets, intermediates vents and cap vents that the cable has been completely injected with the grout having the specified properties. This is basically achieved by confirming through measurement that the grout which flows out at these points has the same density as the grout mix's target density. Ports and vents shall only be closed once it has been confirmed by measurement, that grout which flows out has the required minimum density. Grouting procedures and grouting surveillance shall be carried out according to EN 446.

The quantity of injection product per unit cable length will be calculated as follows:

$$\text{Vol} = [(\text{internal duct section area} - \text{tendon section area}) \times (\text{unit length})] \times (1 + \xi)$$

Where ξ ($0.05 \leq \xi \leq 0.10$) accounts for losses and shape of the duct.

The relevant parameters associated with cable injection shall be recorded on the injection reports.

B.5.2 Sealing

The continuity of protection shall be ensured for the free length of the cable and for the anchorages. Refer to [Clause B.3.1.1](#) and the drawings in [Clause B.6](#).

Filling of the stressing block-out at the anchorages is one provision to protect anchor heads. It may be necessary to complement this measure by a waterproof lining to prevent water from penetrating into the batched up block outs. Alternatively and much better is of course to equip the tendon anchorage with a permanent grout cap.

B.6 Schematic drawing

(dimensions expressed in mm)

Figure 58 Wedge W6N Wedge W6S	118
Figure 59 Wedge W6M (for use with T15.2 strand)	118
Figure 60 Wedge W6ML (for use with spring-loaded coupler)	118
Figure 61 Anchorage type S 6-1 - Unbonded system	119
Figure 62 Anchorage type S 6-1 - Bonded system	120
Figure 63 Anchorage type S 6-1 - Dimensions	121
Figure 64 Anchorage type S 6-1 – Dimension of placing devices	121
Figure 65 Anchorage type S 6-1 PLUS - Unbonded system	122
Figure 66 Anchorage type S 6-1 PLUS - Bonded system	123
Figure 67 Anchorages type S 6-1 PLUS - Dimensions	124
Figure 68 Anchorages type S 6-1 PLUS – Dimensions of placing devices	124
Figure 69 Anchorages type S 6-1 Standard - Unbonded system	125
Figure 70 Anchorage type S 6-1 Standard - Bonded system	126
Figure 71 Anchorage body type S 6-1 Standard	127
Figure 72 Sleeve S 6-1 Standard (for unbonded application)	127
Figure 73 SK 6-1 SL Spring loaded coupler (bonded and unbonded application)	128
Figure 74 SK 6-1 SL Spring loaded coupler body dimensions	128
Figure 75 SK 6-1 SL Spring loaded coupler assembly drawing	128
Figure 76 Anchorage type S 6-4 - Unbonded system	129
Figure 77 Anchorage type S 6-4 - Bonded system	130
Figure 78 Anchorages type S 6-4 - Body and sleeve dimensions	131
Figure 79 Anchorages type S 6-4 – Dimensions of placing devices	131
Figure 80 Example of additional reinforcement to combine with main one type S 6-1 $f_{c,min}(t) > 16/20$ N/mm ²	132
Figure 81 Example of additional reinforcement to combine with main one type S 6-1 PLUS and S 6-1 Standard $f_{c,min}(t) > 16/20$ N/mm ²	132
Figure 82 Example of additional reinforcement to combine with main one type S 6-1 PLUS and S 6-1 Standard $f_{c,min}(t) > 20/25$ N/mm ²	133
Figure 83 Example of additional reinforcement to combine with main one type S 6-4 $f_{c,min}(t) > 16/20$ N/mm ²	134
Figure 84 Stressing jack DKP-6	135
Figure 85 Twin jack 25T	135
Figure 86 Stressing jack ZPE-23FJ	135
Figure 87 Stressing jack Alevin A7/24	135
Figure 88 Clearance requirements with jacks DKP-6 and ZPE 23FJ	136
Figure 89 Clearance requirements with Twin jack 25T	136
Figure 90 Clearance requirements with jack Alevin A7-24	136
Figure 91 VSL PT-PLUS® Duct bonded / bonded / unbonded	137

B.6.1 STANDARD ANCHORAGE ELEMENTS - WEDGES

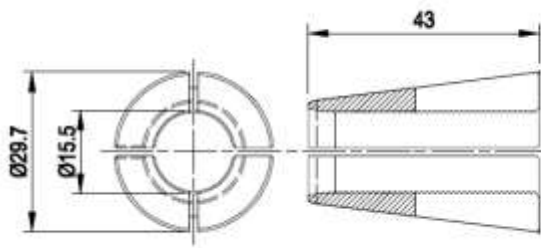
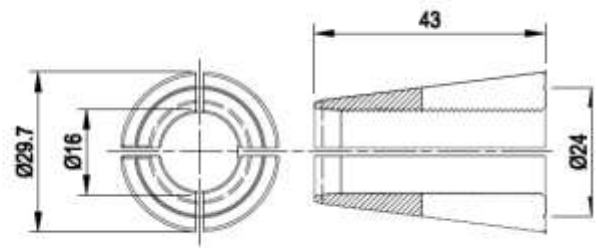

Figure 58 Wedge W6N



Wedge W6S

NB: Wedges W6N and W6S can be fabricated with or without clip.

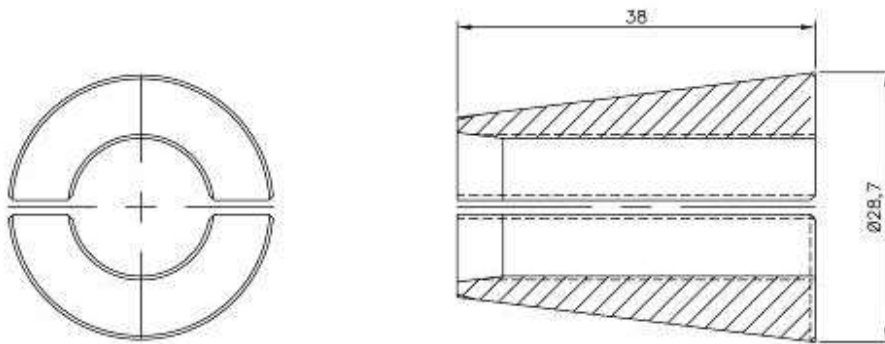

Figure 59 Wedge W6M (for use with T15.2 strand)

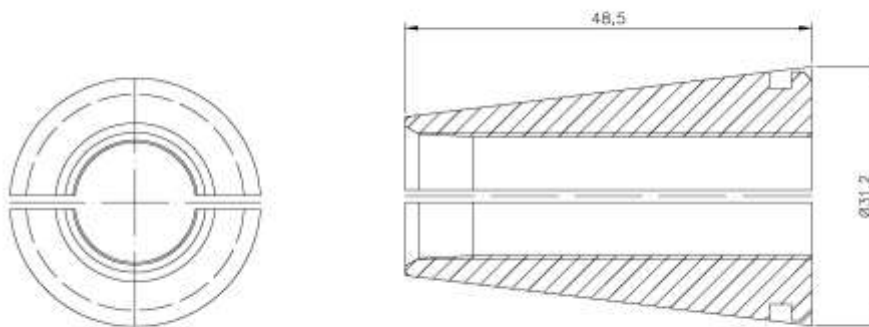

Figure 60 Wedge W6ML (for use with spring-loaded coupler)

B.6.2 ANCHORAGES TYPE S 6-1

B.6.2.1 PRINCIPLE OF UNBONDED SYSTEM – ANCHORAGE S 6-1

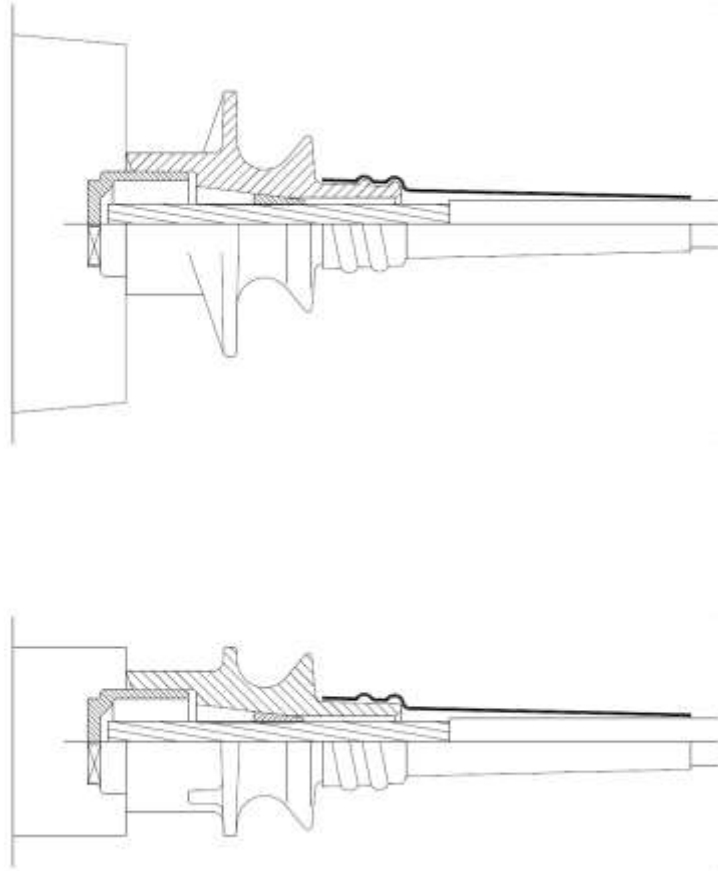

Figure 61 Anchorage type S 6-1 - Unbonded system

Note: The same anchorage body is used for the embedded anchorages S 6-1.

B.6.2.2 PRINCIPLE OF BONDED SYSTEM – ANCHORAGE S 6-1

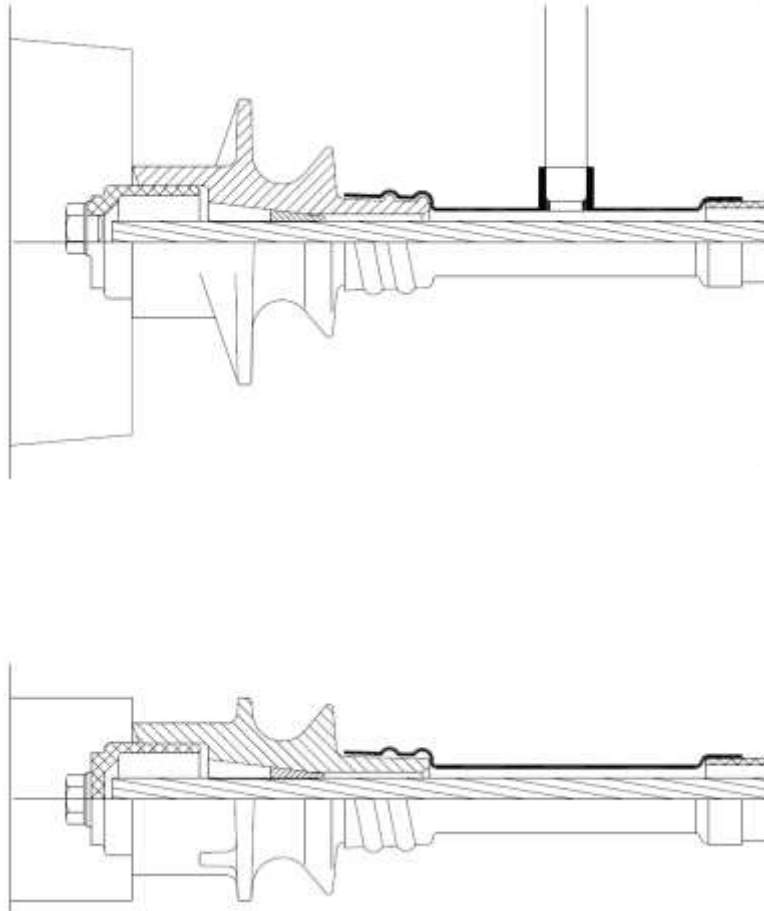

Figure 62 Anchorage type S 6-1 - Bonded system

Note: The same anchorage body is used for the embedded anchorages S 6-1.

B.6.2.3 BODY AND SLEEVE DIMENSIONS – ANCHORAGE S 6-1

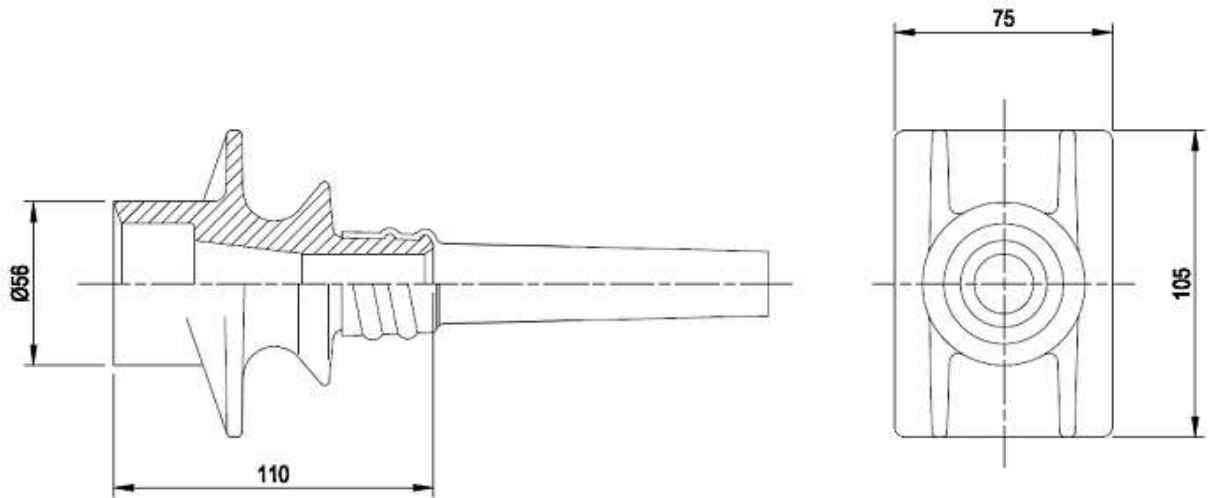

Figure 63 Anchorage type S 6-1 - Dimensions

Note: anchorage S 6-1 can be used as intermediate, dead end or embedded anchorage S 6-1

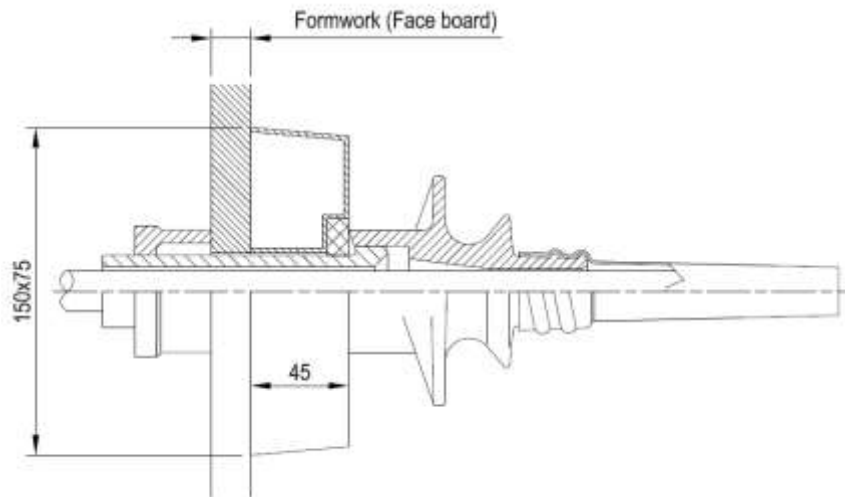

Figure 64 Anchorage type S 6-1 – Dimension of placing devices

B.6.3 ANCHORAGES TYPE S 6-1 PLUS

B.6.3.1 PRINCIPLE OF UNBONDED SYSTEM – ANCHORAGE S 6-1 PLUS

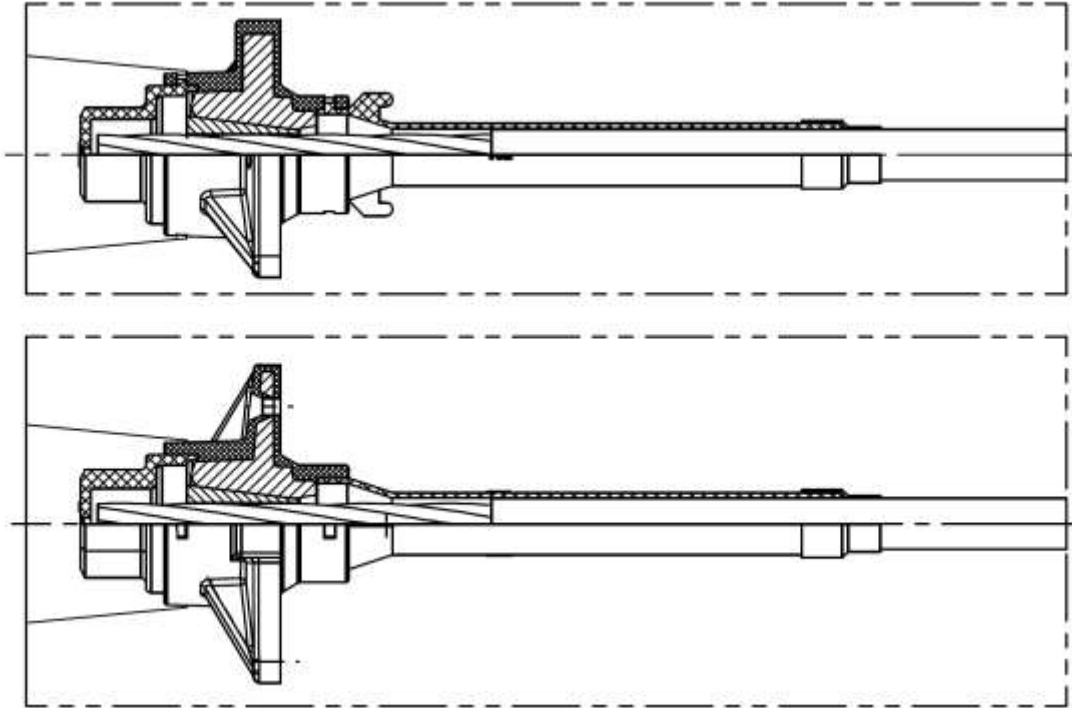

Figure 65 Anchorage type S 6-1 PLUS - Unbonded system

Note: The same anchorage body is used for the embedded anchorages S 6-1 PLUS.

B.6.3.2 PRINCIPLE OF BONDED SYSTEM – ANCHORAGE S 6-1 PLUS

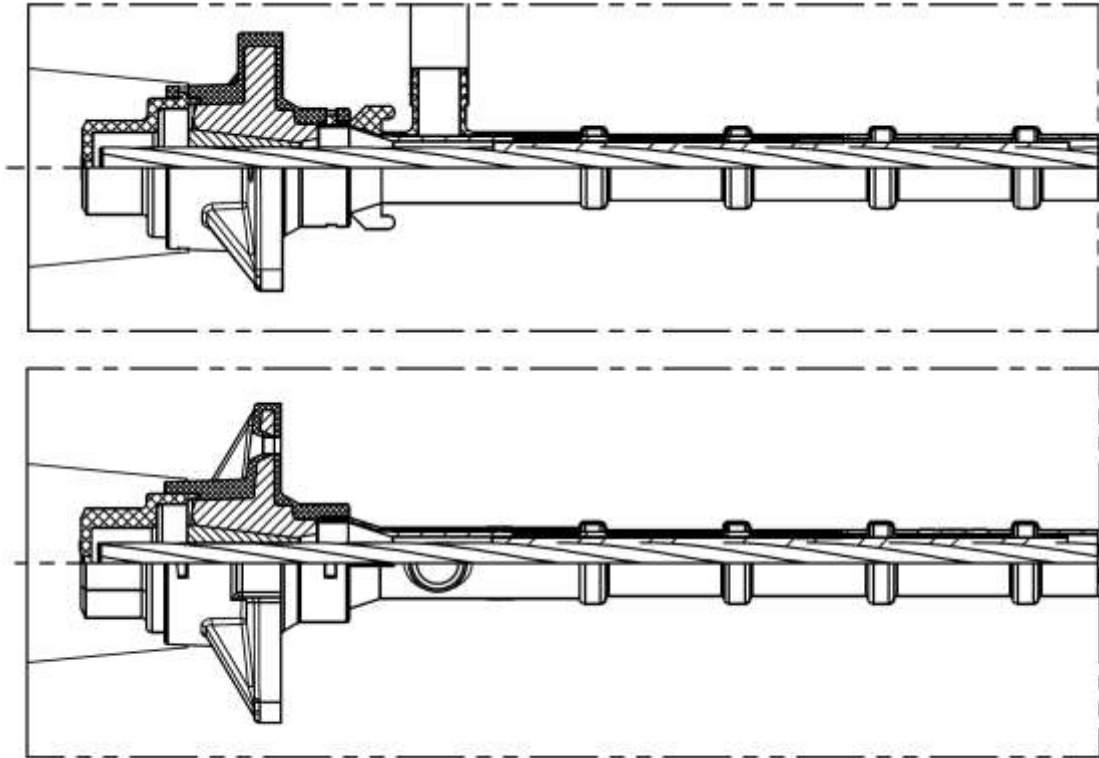

Figure 66 Anchorage type S 6-1 PLUS - Bonded system

Note: The same anchorage body is used for the embedded anchorage S 6-1 PLUS.

B.6.3.3 Body and sleeve dimensions – Anchorage S 6-1 Plus

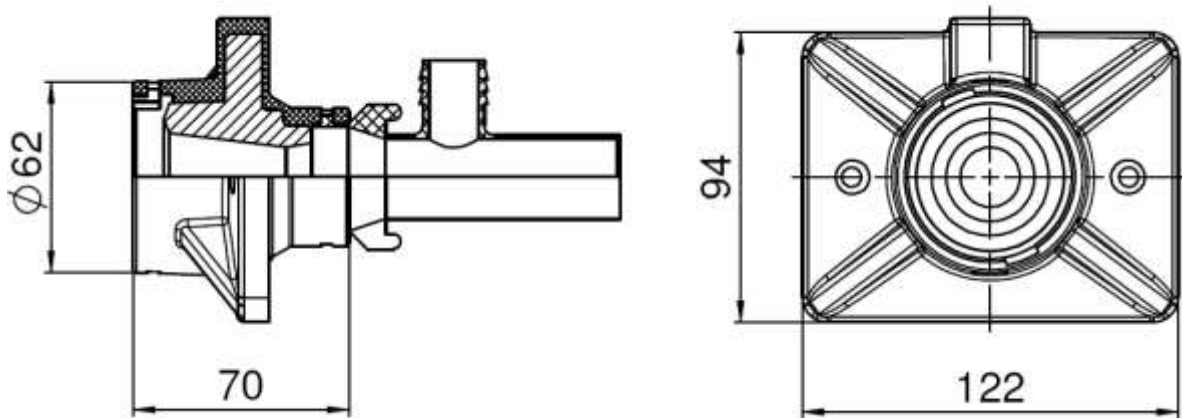

Figure 67 Anchorages type S 6-1 PLUS - Dimensions

Note: The anchorage body S 6-1 PLUS can be used to form an intermediate, dead end or embedded anchorage S 6-1 PLUS

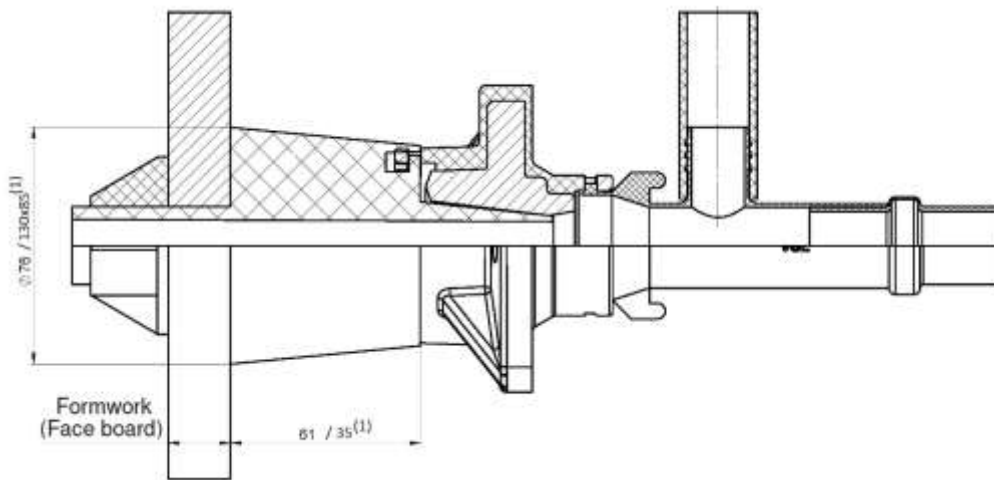

Figure 68 Anchorages type S 6-1 PLUS – Dimensions of placing devices

- (1) Dimensions of recess depend on model of pocket former.

B.6.4 ANCHORAGES TYPE S 6-1 STANDARD

B.6.4.1 PRINCIPLE OF UNBONDED SYSTEM – ANCHORAGE S 6-1 STANDARD

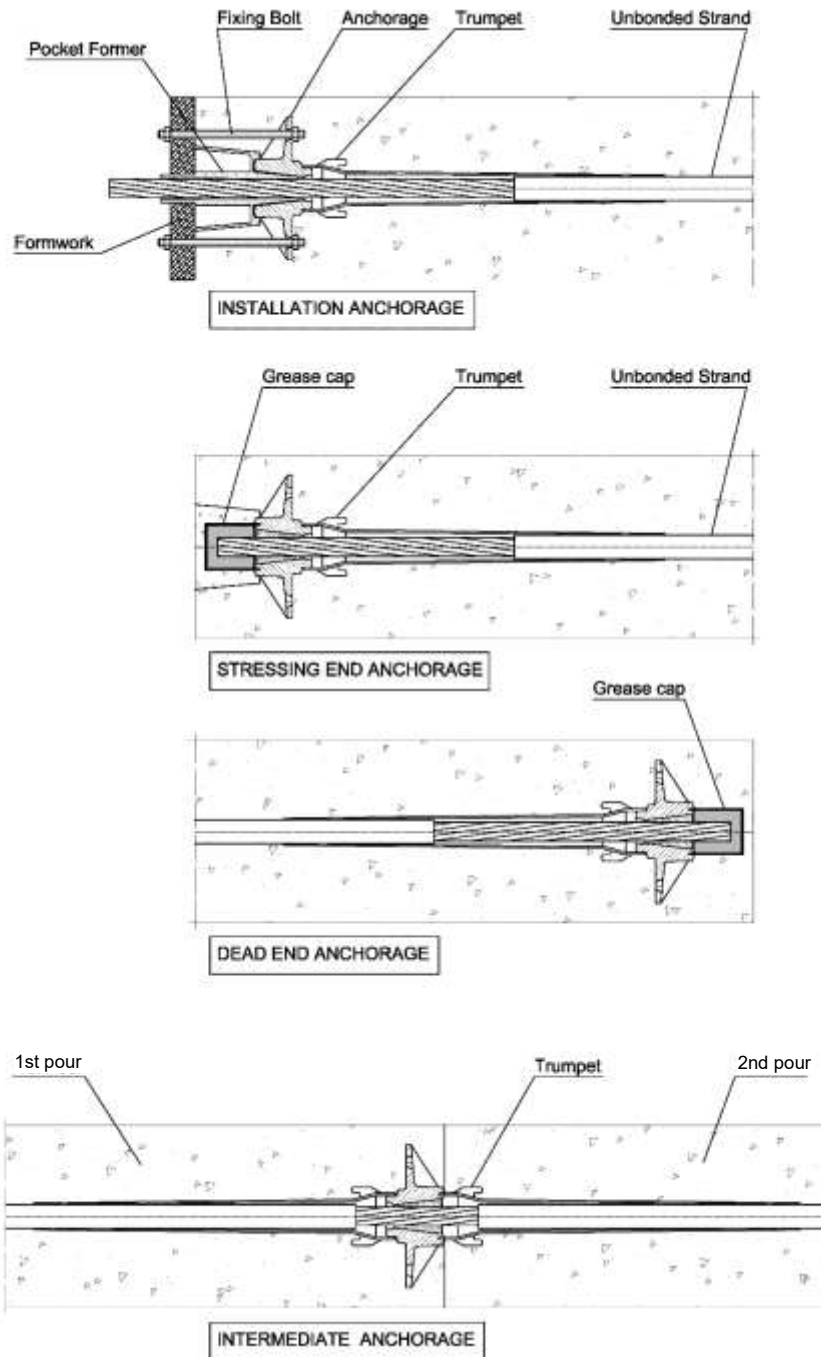

Figure 69 Anchorages type S 6-1 Standard - Unbonded system

B.6.4.2 PRINCIPLE OF BONDED SYSTEM – ANCHORAGE S 6-1 STANDARD

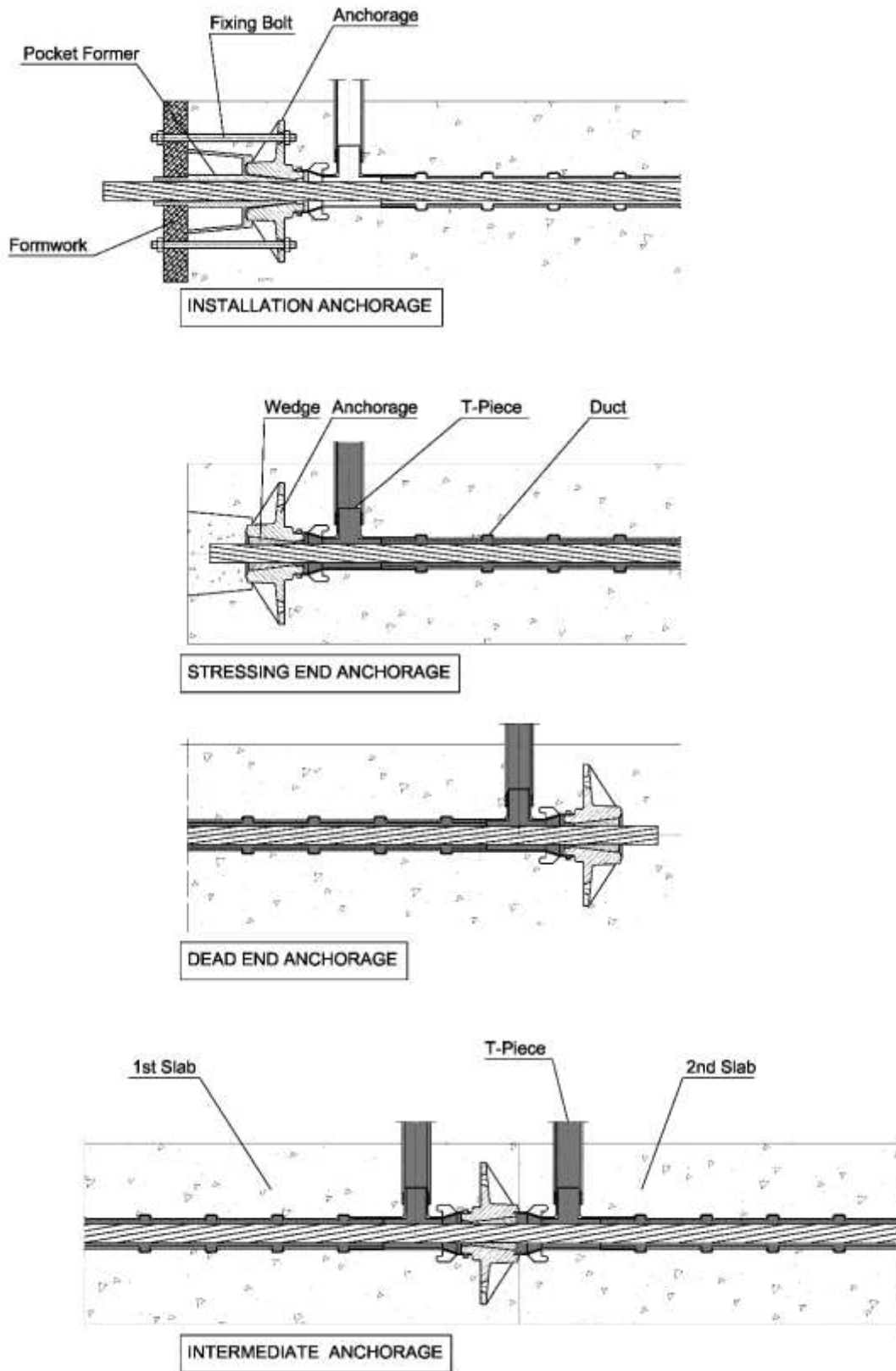

Figure 70 Anchorage type S 6-1 Standard - Bonded system

B.6.4.3 BODY AND SLEEVE DIMENSIONS– ANCHORAGE S 6-1 STANDARD

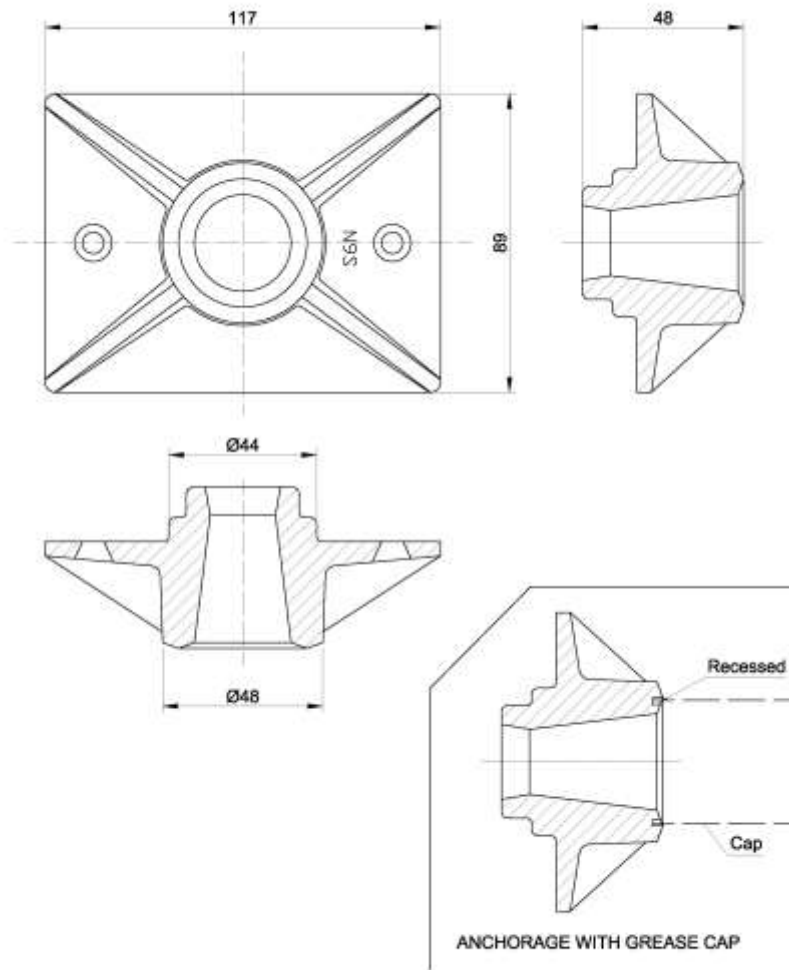

Figure 71 Anchorage body type S 6-1 Standard

Note: The anchorage body S 6-1 Standard can be used to form an intermediate, dead end or embedded anchorage S 6-1 Standard

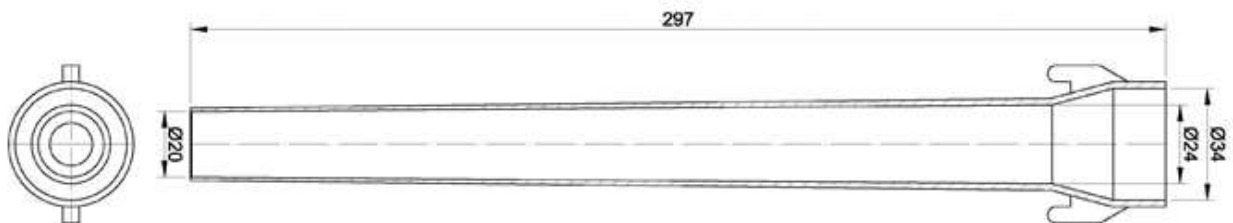

Figure 72 Sleeve S 6-1 Standard (for unbonded application)

B.6.5 SK 6-1 SL SPRING LOADED COUPLER

B.6.5.1 PRINCIPLES OF BONDED AND UNBONDED SYSTEM – SK 6-1 SL COUPLER

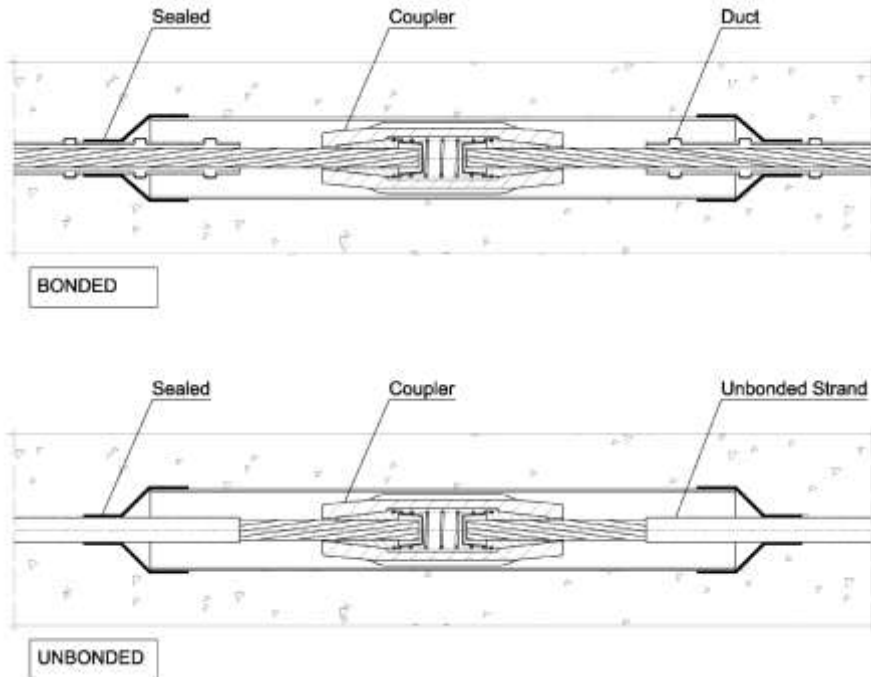

Figure 73 SK 6-1 SL Spring loaded coupler (bonded and unbonded application)

B.6.5.2 DIMENSIONS AND ASSEMBLY – SK 6-1 SL COUPLER

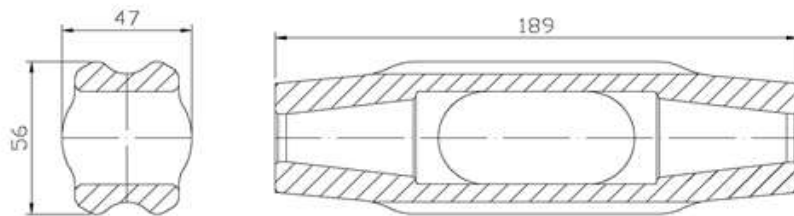

Figure 74 SK 6-1 SL Spring loaded coupler body dimensions

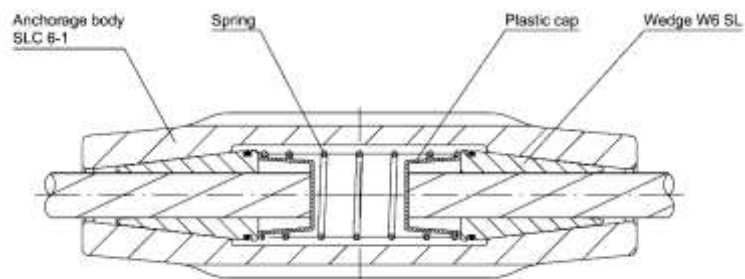

Figure 75 SK 6-1 SL Spring loaded coupler assembly drawing

B.6.6 ANCHORAGES TYPE S 6-4

B.6.6.1 PRINCIPLE OF UNBONDED SYSTEM – ANCHORAGE S 6-4

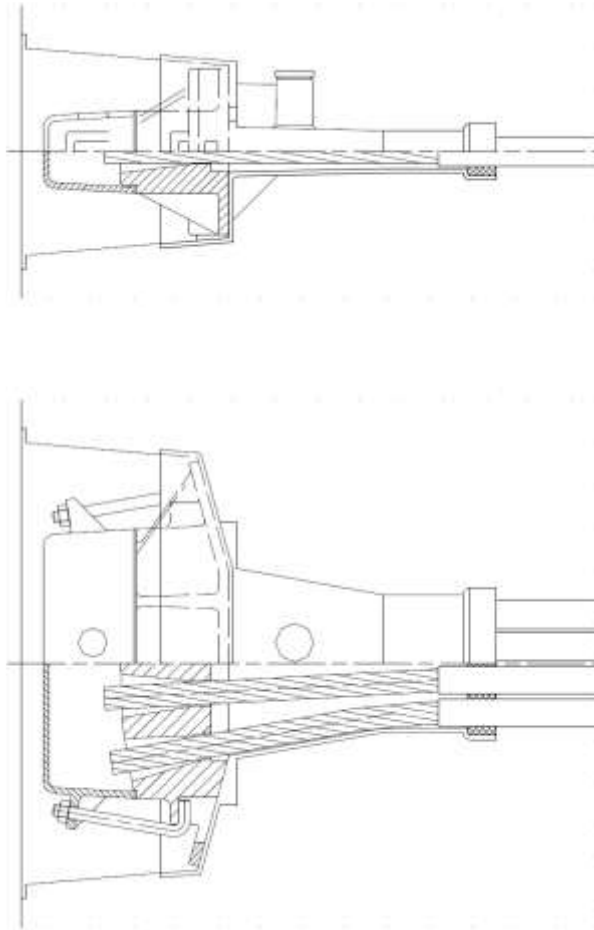

Figure 76 Anchorage type S 6-4 - Unbonded system

B.6.6.2 PRINCIPLE OF BONDED SYSTEM – ANCHORAGE S 6-4

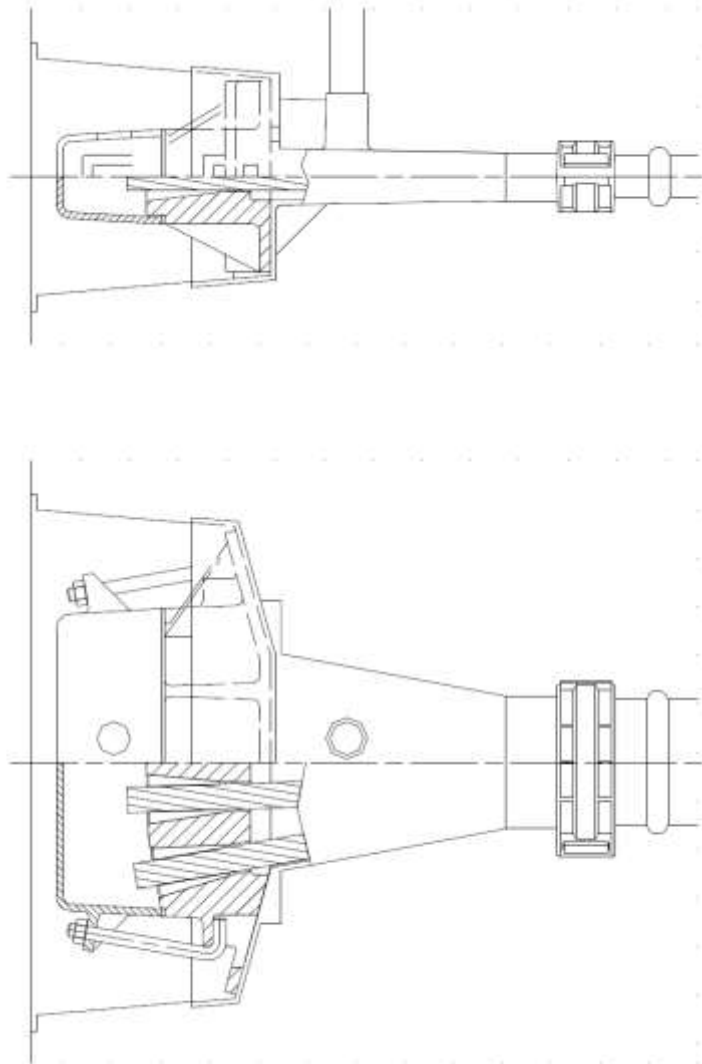

Figure 77 Anchorage type S 6-4 - Bonded system

B.6.6.3 BODY AND SLEEVE DIMENSIONS – ANCHORAGE S 6-4

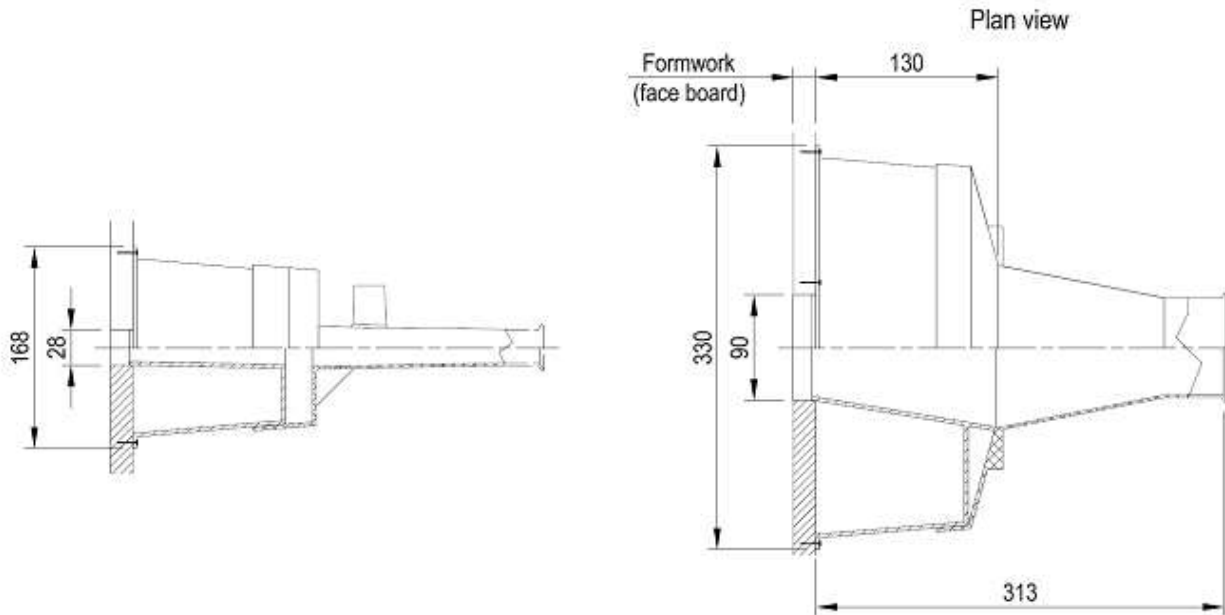

Figure 78 Anchorages type S 6-4 - Body and sleeve dimensions

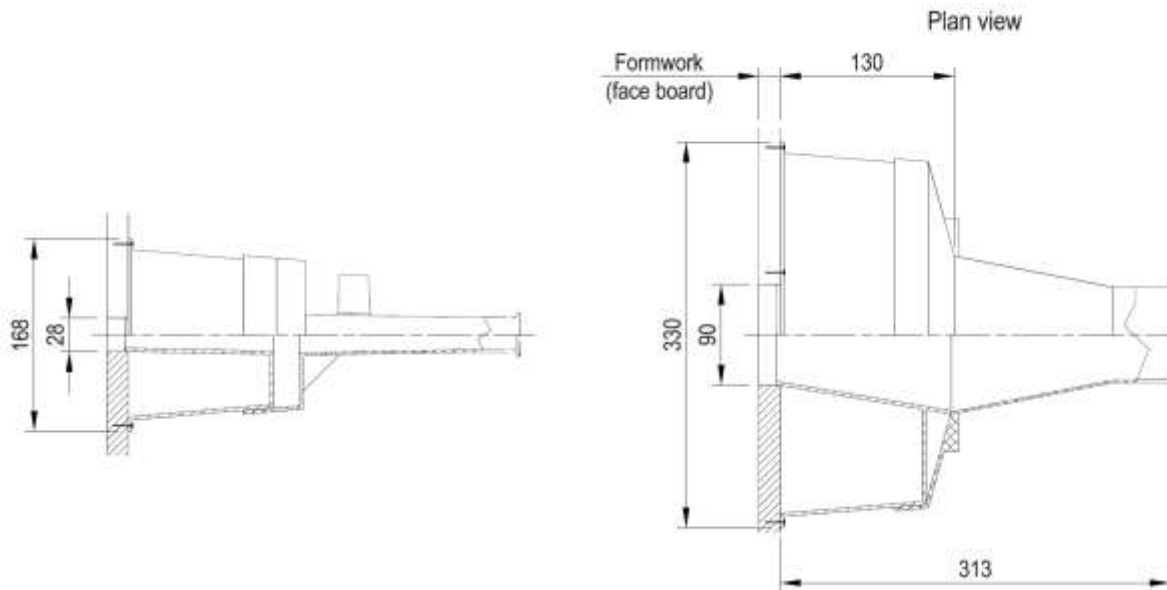

Figure 79 Anchorages type S 6-4 – Dimensions of placing devices

B.6.7 REINFORCEMENT OF ANCHORAGE ZONE - ANCHORAGE S 6-1

With $f_{c,min}(t) > 16/20 \text{ N/mm}^2$ (cylinder /cube strength) and strand Y1860 S7 $\varnothing 15.7$ - T15.7 or 6S with $f_{pk} = 1\,860 \text{ N/mm}^2$, $F_{pk} = 279 \text{ kN}$ and $F_{p0.1k} = 246 \text{ kN}$ or below.

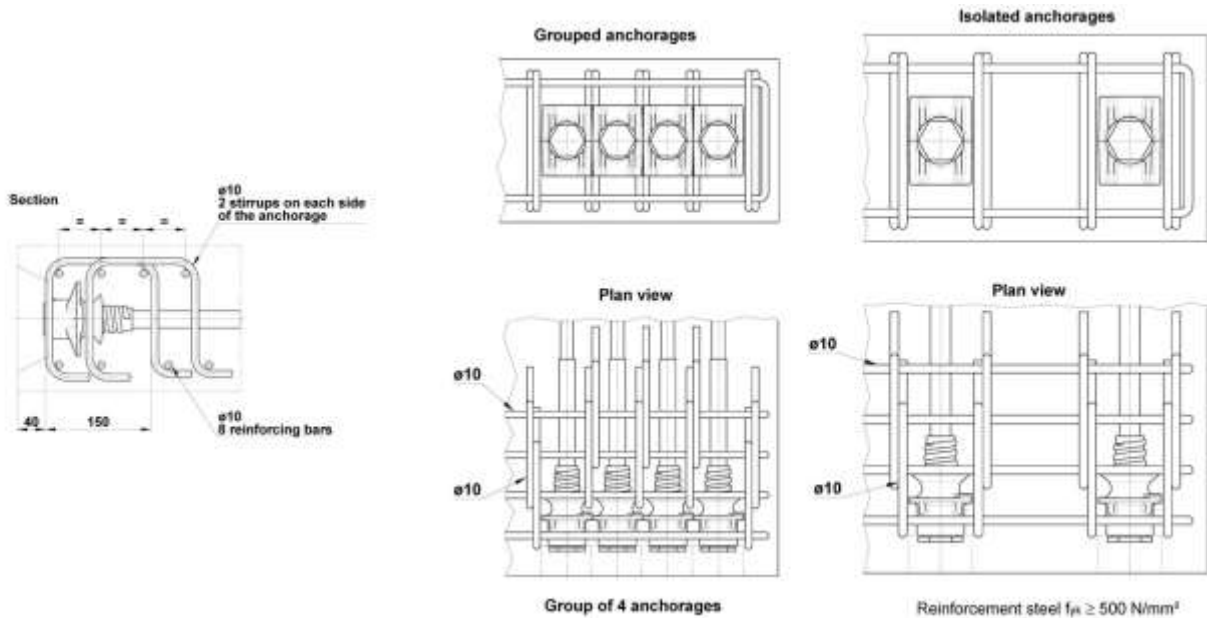

Figure 80 Example of additional reinforcement to combine with main one type S 6-1 $f_{c,min}(t) > 16/20 \text{ N/mm}^2$

B.6.8 REINFORCEMENT OF ANCHORAGE ZONE - ANCHORAGE S 6-1 PLUS & S 6-1 STANDARD

With $f_{c,min}(t) > 16/20 \text{ N/mm}^2$ (cylinder /cube strength) and strand Y1860 S7 $\varnothing 15.7$ - T15.7 or 6S with $f_{pk} = 1\,860 \text{ N/mm}^2$, $F_{pk} = 279 \text{ kN}$ and $F_{p0.1k} = 246 \text{ kN}$ or below.

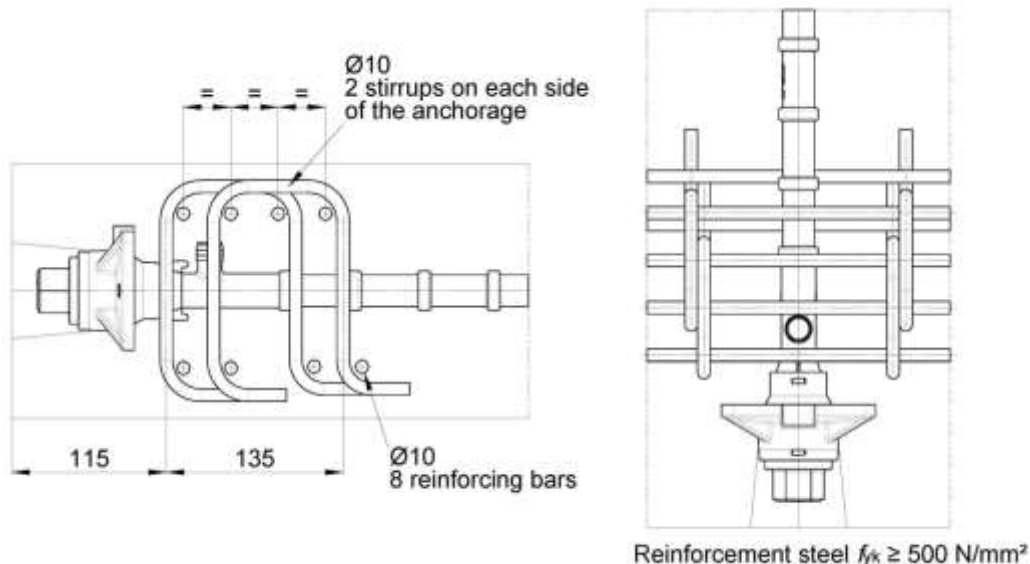

Figure 81 Example of additional reinforcement to combine with main one type S 6-1 PLUS and S 6-1 Standard $f_{c,min}(t) > 16/20 \text{ N/mm}^2$

With $f_{c,min}(t) > 20/25 \text{ N/mm}^2$ (cylinder /cube strength) and strand Y1860 S7 $\varnothing 15.2 - T15.2$ or 6 with $f_{pk} = 1860 \text{ N/mm}^2$, $F_{pk} = 260 \text{ kN}$ and $F_{p0.1k} = 229 \text{ kN}$ or below.

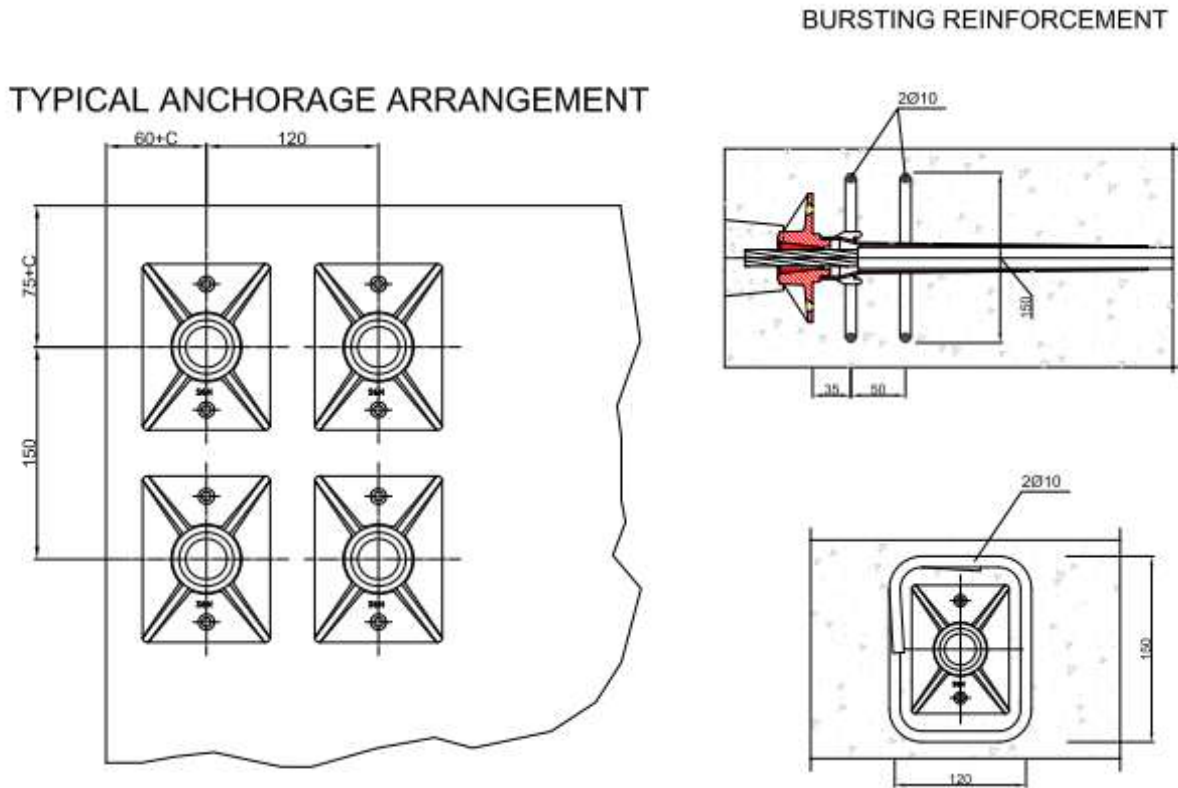

Figure 82 Example of additional reinforcement to combine with main one type S 6-1 PLUS and S 6-1 Standard $f_{c,min}(t) > 20/25 \text{ N/mm}^2$

B.6.9 REINFORCEMENT OF ANCHORAGE ZONE – ANCHORAGE S 6-4

With $f_{c,min}(t) > 16/20 \text{ N/mm}^2$ (cylinder /cube strength) and strand Y1860 S7 $\varnothing 15.7$ - T15.7 or 6S with $f_{pk} = 1860 \text{ N/mm}^2$, $F_{pk} = 279 \text{ kN}$ and $F_{p0.1k} = 246 \text{ kN}$ or below.

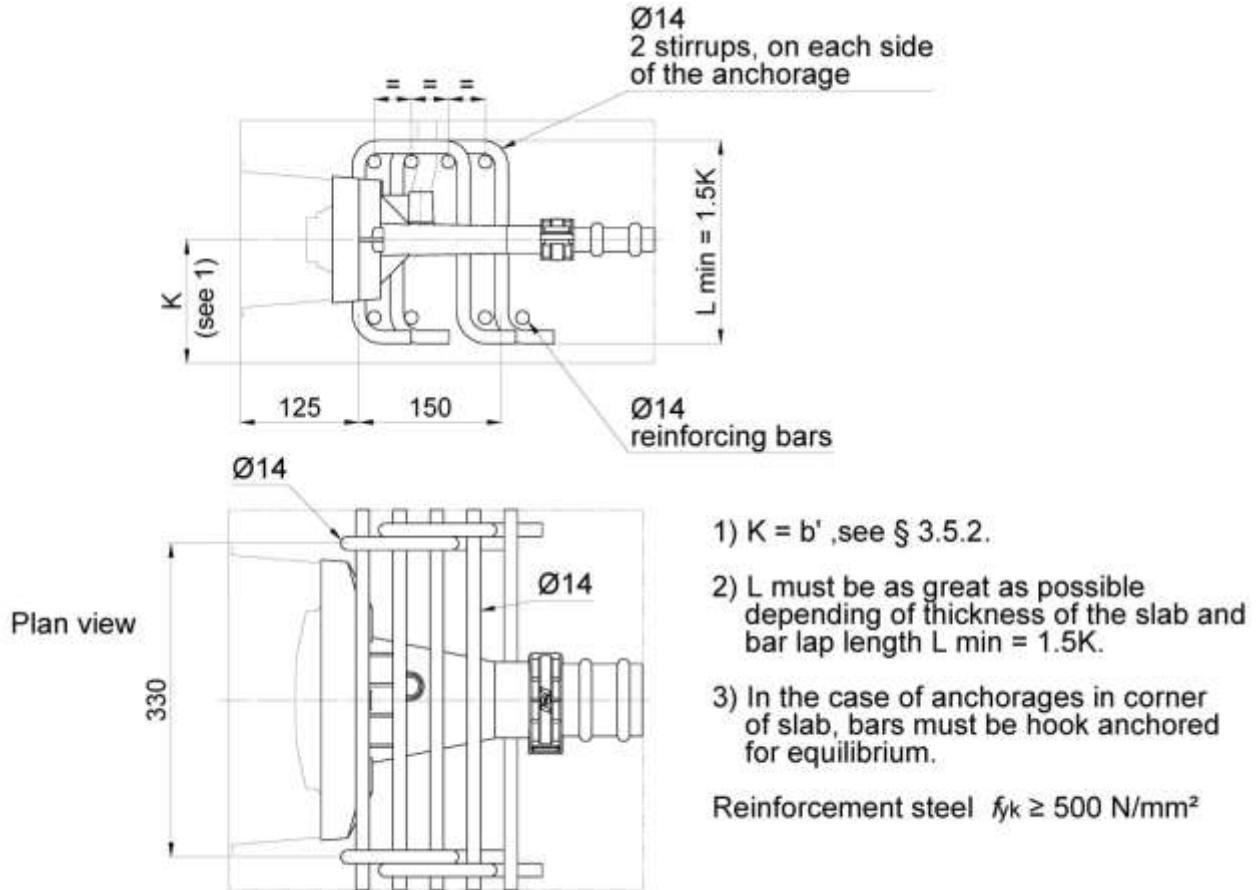

Figure 83 Example of additional reinforcement to combine with main one type S 6-4 $f_{c,min}(t) > 16/20 \text{ N/mm}^2$

B.6.10 STRESSING JACKS AND CLEARANCE REQUIREMENTS

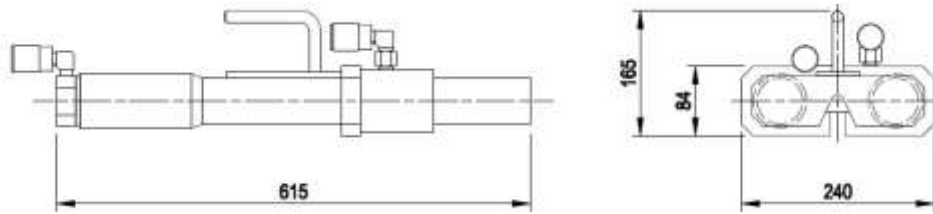

Figure 84 Stressing jack DKP-6

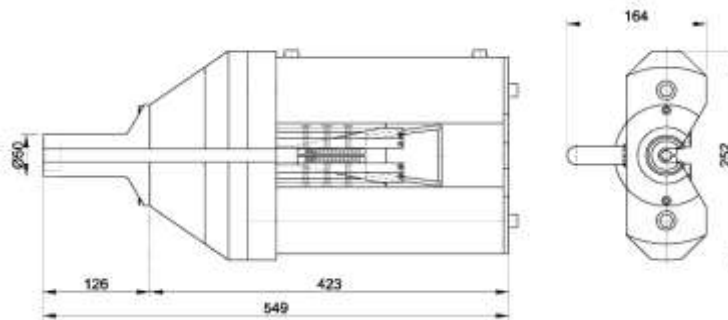

Figure 85 Twin jack 25T

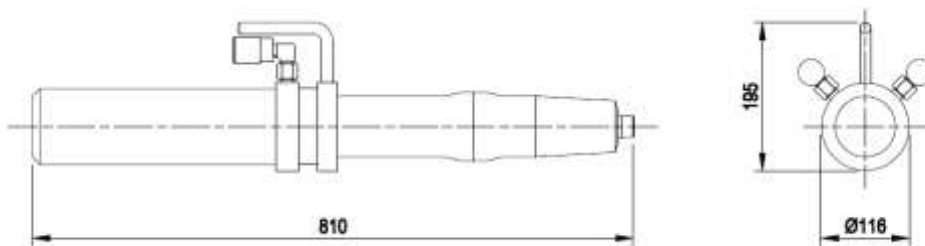

Figure 86 Stressing jack ZPE-23FJ

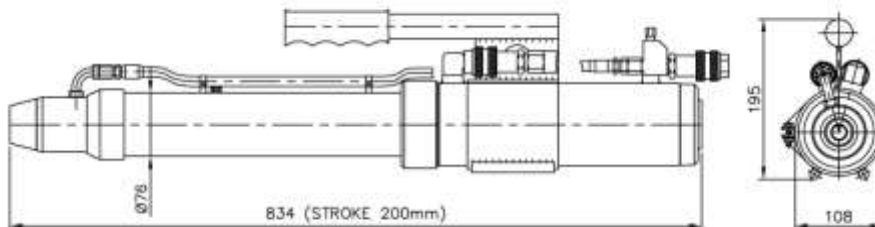

Figure 87 Stressing jack Alevin A7/24

VSL Post-Tensioning System

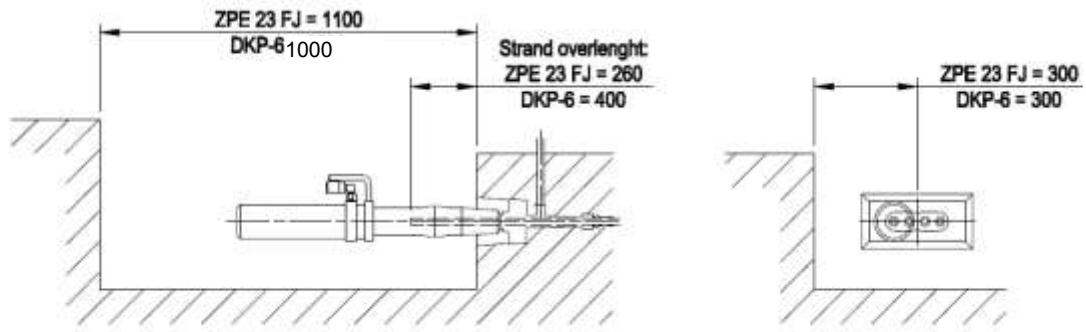

Figure 88 Clearance requirements with jacks DKP-6 and ZPE 23FJ

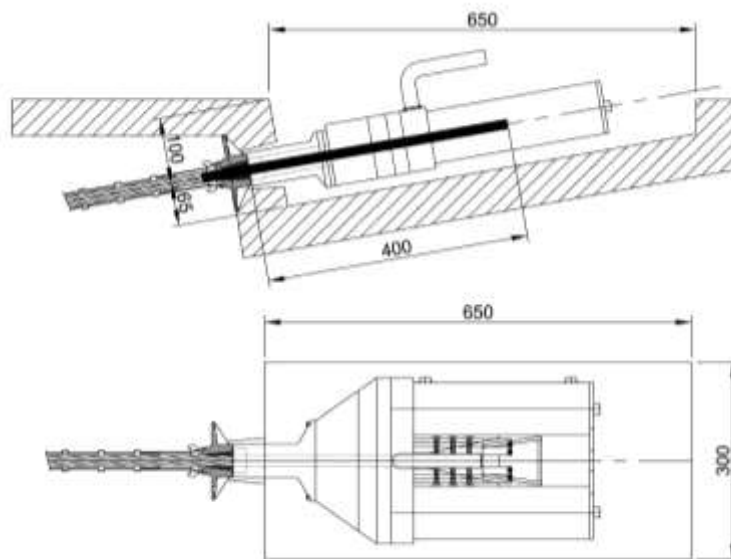

Figure 89 Clearance requirements with Twin jack 25T

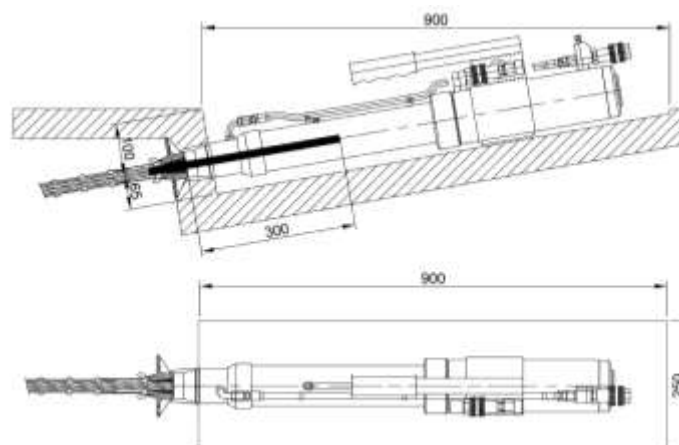

Figure 90 Clearance requirements with jack Alevin A7-24

Notes: Other models of jacks can be used if they are accepted by VSL. Refer to the latest revision of the VSL PT brochure or contact VSL for an updated list of equipment.

The above dimensions depend on the post-tensioning units and the available jacks. They may be reduced if absolutely necessary. In such cases, consult the VSL Technical Centres.

B.6.11 DUCTING

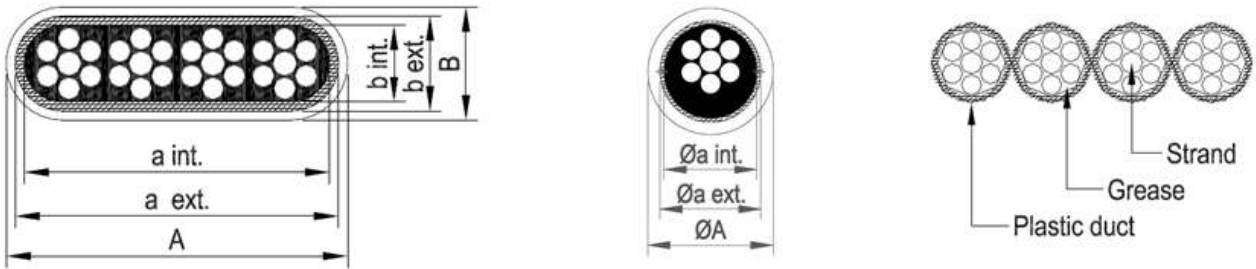

Figure 91 VSL PT-PLUS® Duct bonded / bonded / unbonded

Bonded

	Corrugated steel strip sheath	VSL PT-PLUS® Duct
a int.	72	72
a ext.	-	76
A	75	86
b int.	18	21
b ext.	-	25
B	21	35

Bonded

	VSL PT-PLUS® Duct
Øa int.	22
Øa ext.	25
ØA	31

Unbonded

Ø Strand	Ø ext. duct Min / Max
0.6"	18 / 20

Annex C PRESCRIBED TEST PLAN AND AUDIT TESTING

C.1 Prescribed test plan

1	2	3	4	5	6
Component	Item	Test / Check	Traceability ⁴	Minimum frequency	Documentation
Anchor plate	Material ⁷	Check	bulk ⁶	100 % ⁸	2.2 or 3.1 ¹
	Detailed dimensions ⁵	Test		3 % ⁸ ≥ 2 elements	Yes
	Visual inspection ³	Check		100 % ⁸	No
Anchor head, Coupler, Deviator components	Material ⁷	Check	full	100 % ⁸	3.1 ²
	Detailed dimensions ⁵	Test		5 % ⁸ ≥ 2 elements	Yes
	Visual inspection ³	Check		100 % ⁸	No
Wedges, Compression fitting	Material ⁷	Check	full	100 % ⁸	3.1 ²
	Treatment, hardness	Test		0.5 % ⁸ ≥ 2 elements	Yes
	Detailed dimensions ⁵	Test		5 % ⁸ ≥ 2 elements	Yes
	Visual inspection ³	Check		100 % ⁸	No
Duct	Material ⁶	Check	CE ²	100 %	CE ²
	Visual inspection ³	Check		100 %	No
Strand	Material ⁶	Check	National Certification till CE ²	100 %	CE ²
	Diameter	Test		Each coil	No
	Visual inspection ³	Check		Each coil	No
Constituents of filling material as per EN 447	Cement ⁶	Check	Full	100 %	CE ²
	Admixtures, additions ⁶	Check	Bulk	100 %	CE ²
Monostrand	Material ⁶	Check	National Certification till CE ²	100 %	CE ⁷
Plastic pipes	Material ⁶	Check	full	100 %	CE ²
Corrugated polymeric ducts	Material and system components	According to <i>fib Bulletin 75</i> , Chapter 9	full	100 %	CE ⁷

All samples are to be extracted at random and clearly identified.

VSL Post-Tensioning System

Details on sampling procedures including methods of recording as well as test methods have been agreed between the Technical Assessment Body and the Manufacturer as part of the prescribed test plan. Preferably standardized sampling and test methods are used. Generally all results are reported in the test reports in such a way to enable direct comparison with the specification data in the ETA or subsidiary documentation.

- 1 2.2 or 3.1: Test report type 2.2 (simple steel anchor plates) or inspection certificate 3.1 (cast bearing plates) according to EN 10204.
- 2 3.1: Inspection certificate type 3.1 according to EN 10204.
If the basis of CE-marking is not available, the prescribed test plan has to include appropriate measures, only for the time until the harmonized technical specification is available.
- 3 Visual inspection of general aspects such as main dimensions, external aspect, correct marking/labelling, regularity of surface, absence of visual defaults, smoothness, absence of corrosion, coating, etc. unless covered in other items already of the prescribed test plan. The objective of this inspection is to ensure that the component corresponds to its description and to detect any non-conformity that is visible to an inspector who is knowledgeable in the particular component.
- 4 full: Full traceability of each component to its raw material.
bulk: Traceability of each delivery of components to a defined point.
- 5 Detailed dimensions mean measuring of all dimensions and angles according to the specifications as given in the prescribed test plan.
- 6 Material checks are included for information only as these are not part of the prescribed test plan.
- 7 If the basis of CE-marking is not available, the prescribed test plan has to include appropriate measures. The certificate shall be based on specific testing on the fabrication batch from which the supply has been produced, to confirm specified properties, and shall be prepared by a department of the supplier which is independent of the production department.
- 8 Procedure according to VSL Final Control Specifications.

Note: Generally speaking, all tests, inspections, etc. are aimed at verifying that the information contained in manufacturing drawings and in the relevant specifications has actually been applied to the components.

C.2 Audit testing

During surveillance inspections, the Notified Body has to take samples of components of the PT System or the relative individual components for which the ETA has been granted for independent testing. For the most important components, the table given below summarises the minimum procedures which are performed by the Notified Body.

1 Component	2 Item	3 Test / Check	4 Sampling Number of components per visit
Bearing plates and other force transfer units	Material according to specification	Check, test	1/year
	Detailed dimensions	Test	
	Visual inspection ¹⁰	Check	
Anchor head, Coupler, Deviator components	Material according to specification	Check, test	1/year
	Detailed dimensions	Test	
	Visual inspection ¹⁰	Check	
Wedges, Compression fitting	Material according to specification	Check, test	2/year
	Treatment	Test	2/year
	Detailed dimensions	Test	1/year
	Main dimensions, surface hardness	Test	5/year
	Visual inspection ¹⁰	Check	5/year
Corrugated plastic/polymeric ducts	According to <i>fib Bulletin 75</i> , Chapter 9	Check, test	1 series/year (1 for material; 2 duct sizes and 2 components)
Single tensile element test	Single tensile element test according to EAD 160004-00-0301, Annex C.7	Test	1 series/year
Grout	Grout tests as per items 11 to 18 of Table 3 (including, among others Inclined tube and wick induced tests) of EAD 160027-00-0301 ¹¹	Test	1 series of tests/year

All samples are to be randomly selected and clearly identified.

Details on sampling procedures including methods of recording as well as test methods shall be agreed between the Notified Assessment Body and the Manufacturer as part of the prescribed test plan. Preferably standardized sampling and test methods are used. Generally all results are reported in the test reports in such a way to enable direct comparison with the specifications in the ETA or subsidiary documentation.

¹⁰ Visual inspection of general aspects such as main dimensions, external aspect, correct marking/labelling, regularity of surface, absence of visual defaults, smoothness, absence of corrosion, coating, etc. unless covered in other items already of the prescribed test plan. The objective of this inspection is to ensure that the component corresponds to its description and to detect any non-conformity that is visible to an inspector who is knowledgeable in the particular component.

¹¹ Applied to special grout specified within EAD 160027-00-0301 and this ETA.

Annex D REFERENCE STANDARDS AND GUIDELINES

D.1 Material and reference standards

Component	Material	Standard
Anchorage plate	Structural steel	EN 10025-2, GB/T 1591
Shim (machined)	Structural steel	EN ISO 683-1, GB/T 3077, GB/T 8162, GB/T 17107
Cast iron plate, XT-pad & shim	Cast iron	EN 1561, EN 1563, GB/T 9439, GB/T 1348
Anchor head	Steel for quenching and tempering	EN ISO 683-1, EN ISO 683-2, GB/T 3077, GB/T 17107, ASTM A897 M
Monostrand coupler	Cast iron	ASTM A897 M, EN 1564
Wedges	Case hardening or free-cutting steel	EN ISO 683-3, EN ISO 683-4, GB/T 3077, GB/T 5216
Compression fittings	Unalloyed steel	EN ISO 683-1
Corrugated sheaths	Metal strip	EN 523
Polymeric duct	Polymeric material	fib Bulletin 113
Deviation pad	Polymeric material	-
Grout	Cement, additives	EN 447
Strand	Steel strand	prEN 10138-3

NB: Exact materials and properties are deposited at Cerema ITM

D.2 EADs and recommendations

European Assessment Documents

EAD 160004-00-0301 edition September 2016 of “Post-tensioning kits for prestressing of structures”

EAD 160027-00-0301 edition September 2016 of “Special filling products for post-tensioning kits”

CEB-FIP Recommendations

fib Bulletin No. 33 - 2005: “Durability of post-tensioning tendons”. Recommendation

fib Bulletin No. 113 - 2024: “Polymer-duct systems for internal bonded post-tensioning”. Recommendation

D.3 Standards and norms

ASTM A897 M (2016)	“Standard Specification for Austempered Ductile Iron Castings”
EN 445:2007	“Grout for prestressing of tendons – Test methods”
EN 446:2007	“Grout for prestressing of tendons – Grouting procedures”
EN 447:2007	“Grout for prestressing of tendons – Specification for common grout”
EN 523:2003	“Steel strip sheaths for prestressing tendons – Terminology, requirements, quality control”
EN 1561:2023	“Founding – Grey cast irons”
EN 1563:2018	“Founding – Spheroidal graphite cast irons”
EN 1564:2011	“Founding – Ausferritic spheroidal graphite cast irons”
EN 1992-1-1:2004	“Eurocode 2: Design of concrete structures. Part 1-1: General rules and rules for buildings”
EN 10025-2:2019	“Hot rolled products of structural steel. Part 2 : technical delivery conditions for non-alloy structural steels”
prEN 10138-3:2006	“Prestressing steels – Part 3: Strand”
EN 10204:2004	“Metallic products – Types of inspection documents”
EN 10216-1:2014	“Seamless steel tubes for pressure purposes - Technical delivery conditions – Part 1: Non-alloy steel tubes with specified room temperature properties”
EN 10217-1:2019	“Welded steel tubes for pressure purposes - Technical delivery conditions – Part 1: Non-alloy steel tubes with specified room temperature properties”
EN 10219-1:2006	“Cold formed welded structural hollow sections of non-alloy and fine grain steels - Part 1: Technical delivery conditions”
EN 10255:2005 +A1:2007	“Non-Alloy steel tubes suitable for welding and threading - Technical delivery conditions”
EN 10305-3:2023	“Steel tubes for precision applications - Technical delivery conditions - Part 3: Welded cold sized tubes”
EN 12201-1:2024	“Plastic piping systems for water supply- Polyethylene”
EN 13391:2004	“Mechanical tests for Post-tensioning systems”
EN 13670:2013	“Execution of concrete structures”
EN 17678-1:2022	“Installation of post-tensioning kits for prestressing of structures – Part 1: Competence of personnel”
EN 17678-2:2023	“Installation of post-tensioning kits for prestressing of structures – Part 2: Assessment of personnel”
EN ISO 683-1:2018	“Heat treatable steels, alloy steels and free-cutting steels - Part 1: non alloy steels for quenching and tempering”
EN ISO 683-2:2018	“Heat treatable steels, alloy steels and free-cutting steels - Part 2: alloy steels for quenching and tempering”
EN ISO 683-3:2022	“Heat-treatable steels, alloy steels and free-cutting steels - Part 3: case hardening steels”
EN ISO 683-4:2018	“Heat treatable steels, alloy steels and free-cutting steels - Part 4: freecutting steels”
EN ISO 9001:2015	“Quality management systems-Requirements”
GB/T 1348:2019	“Spheroidal graphite iron castings”
GB/T 1591:2018	“High strength low alloy structural steels “
GB/T 3077:1999	“Alloy structure steels”
GB/T 8162:2018	“Seamless steel tubes for structural purposes”
GB/T 9439:2023	“Grey iron castings”
GB/T 5216:2004	“Structural steels subject to end-quench hardenability requirements”
GB/T 17107:1997	“Structural steel grades and mechanical property for forgings”
NF A35-037-2:2021	“Steel products - Protected and sheathed high strength steel strands - Part 2: Requirements for sliding protected and sheathed strands (type P)”
NF A35-037-3:2021	“Steel products - Protected and sheathed high strength steel strands - Part 3: Requirements for adherent protected sheathed strands (type SC)”